

CBR1000ST/SP

CBR1000ST/SP

EN

OWNER'S MANUAL



This manual should be considered a permanent part of the vehicle and should remain with the vehicle when it is resold.

This publication includes the latest production information available before printing. Honda Motor Co., Ltd. reserves the right to make changes at any time without notice and without incurring any obligation.

No part of this publication may be reproduced without written permission.

The vehicle pictured in this owner's manual may not match your actual vehicle.

**India only**

For any query or assistance, please call Customer care number: 1800 103 3434 (Toll free)

# Welcome

Congratulations on your purchase of a new Honda vehicle. Your selection of a Honda makes you part of a worldwide family of satisfied customers who appreciate Honda's reputation for building quality into every product.

To ensure your safety and riding pleasure:

- Read this owner's manual carefully.
- Follow all recommendations and procedures contained in this manual.
- Pay close attention to safety messages contained in this manual and on the vehicle.
- The following codes in this manual indicate each country.
- The illustrations here in are based on the CBR1000ST ED type.

## Country Codes

Code	Country
------	---------

### CBR1000ST

ED, II ED	European direct sales Costa Rica, Guatemala, India Nepal, Hong Kong, Macao Argentina, South Africa, Jordan Lebanon, Turkey
U, II U	Australia, New Zealand
II GS	GCC Countries

### CBR1000SP

ED, II ED	European direct sales Costa Rica, Guatemala, India Nepal, Hong Kong, Macao Argentina, South Africa, Jordan Lebanon, Turkey
U, II U	Australia, New Zealand
II GS	GCC Countries

\*The specifications may vary with each locale.

## A Few Words About Safety

Your safety, and the safety of others, is very important. Operating this vehicle safely is an important responsibility.

To help you make informed decisions about safety, we have provided operating procedures and other information on safety labels and in this manual. This information alerts you to potential hazards that could hurt you or others.

Of course, it is not practical or possible to warn you about all hazards associated with operating or maintaining a vehicle. You must use your own good judgement.

You will find important safety information in a variety of forms, including:

- Safety labels on the vehicle
- Safety Messages preceded by a safety alert symbol  and one of three signal words: DANGER, WARNING, or CAUTION.

These signal words mean:

### **DANGER**

You **WILL** be **KILLED** or **SERIOUSLY HURT** if you don't follow instructions.

### **WARNING**

You **CAN** be **KILLED** or **SERIOUSLY HURT** if you don't follow instructions.

### **CAUTION**

You **CAN** be **HURT** if you don't follow instructions.

**Other important information is provided under the following titles:**

**NOTICE** Information to help you avoid damage to your vehicle, other property, or the environment.

# Contents

**Vehicle Safety** P. 2

**Operation Guide** P. 22

**Maintenance** P. 127

**Troubleshooting** P. 195

**Information** P. 221

**Specifications** P. 240

**Index** P. 243

# Vehicle Safety

This section contains important information for safe riding of your vehicle.  
Please read this section carefully.

<b>Safety Guidelines</b> .....	P. 3
<b>Image Labels</b> .....	P. 7
<b>Safety Precautions</b> .....	P. 13
<b>Riding Precautions</b> .....	P. 15
<b>Accessories &amp; Modifications</b> .....	P. 20
<b>Loading</b> .....	P. 21

## Safety Guidelines

Follow these guidelines to enhance your safety:

- Perform all routine and regular inspections specified in this manual.
- Stop the engine and keep sparks and flame away before filling the fuel tank.
- Do not run the engine in enclosed or partly enclosed areas. Carbon monoxide in exhaust gases is toxic and can kill you.

### Always Wear a Helmet

It's a proven fact: helmets and protective apparel significantly reduce the number and severity of head and other injuries. So always wear an approved helmet and protective apparel. 📖 P. 13

### Before Riding

Make sure that you are physically fit, mentally focused and free of alcohol and drugs. Check that you and your passenger are both wearing an approved helmet and protective apparel. Instruct your passenger on holding onto the seat strap or your waist, leaning with you in turns, and keeping their feet on the footpegs, even when the vehicle is stopped.

### Take Time to Learn & Practice

Even if you have ridden other vehicles, practice riding in a safe area to become familiar with how this vehicle works and handles, and to become accustomed to the vehicle's size and weight.

## Safety Guidelines

### Ride Defensively

Always pay attention to other vehicles around you, and do not assume that other drivers see you. Be prepared to stop quickly or perform an evasive maneuver.

### Make Yourself Easy to See

Make yourself more visible, especially at night, by wearing bright reflective clothing, positioning yourself so other drivers can see you, signaling before turning or changing lanes, and using your horn when necessary.

### Ride within Your Limits

Never ride beyond your personal abilities or faster than conditions warrant. Fatigue and inattention can impair your ability to use good judgement and ride safely.

### Don't Drink and Ride

Alcohol and riding don't mix. Even one alcoholic drink can reduce your ability to respond to changing conditions, and your reaction time gets worse with every additional drink. Don't drink and ride, and don't let your friends drink and ride either.

### Keep Your Honda in Safe Condition

It's important to keep your vehicle properly maintained and in safe riding condition. Inspect your vehicle before every ride and perform all recommended maintenance. Never exceed load limits (➤ P. 21), and do not modify your vehicle or install accessories that would make your vehicle unsafe (➤ P. 20).



## If You are Involved in a Crash

Personal safety is your first priority. If you or anyone else has been injured, take time to assess the severity of the injuries and whether it is safe to continue riding. Call for emergency assistance if needed. Also follow applicable laws and regulations if another person or vehicle is involved in the crash.

If you decide to continue riding, first turn the electrical system off, and evaluate the condition of your vehicle. Inspect for fluid leaks, check the tightness of critical nuts and bolts, and check the handlebars, control levers, brakes, and wheels. Ride slowly and cautiously.

Your vehicle may have suffered damage that is not immediately apparent. Have your vehicle thoroughly checked at a qualified service facility as soon as possible.

## Lithium-Ion (Li-Ion) Battery

### CBR1000SP

If you smell an unusual odor coming from the lithium-ion (li-ion) battery, park your vehicle in a safe place outside and away from flammable objects, then turn the electrical system off. Have your vehicle inspected by your dealer immediately.

### Carbon Monoxide Hazard

Exhaust contains poisonous carbon monoxide, a colourless, odorless gas. Breathing carbon monoxide can cause loss of consciousness and may lead to death.

If you run the engine in confined or even partly enclosed area, the air you breathe could contain a dangerous amount of carbon monoxide.

Never run your vehicle inside a garage or other enclosure.

### **WARNING**

Running the engine of your vehicle while in an enclosed or even partially enclosed area can cause a rapid build-up of toxic carbon monoxide gas.

Breathing this colourless, odorless gas can quickly cause unconsciousness and lead to death.

Only run your vehicle's engine when it is located in a well ventilated area outdoors.

## Image Labels

The following pages describe the label meanings. Some labels warn you of potential hazards that could cause serious injury. Others provide important safety information. Read this information carefully and don't remove the labels.

If a label comes off or becomes hard to read, contact your dealer for a replacement.

There is a specific symbol on each label. The meanings of each symbol and label are as follows.



Read instructions contained in Owner's Manual carefully.



Read instructions contained in Shop Manual carefully. In the interest of safety, take the vehicle to be serviced only by your dealer.

### **DANGER (with RED background)**

You **WILL** be **KILLED** or **SERIOUSLY HURT** if you don't follow instructions.

### **WARNING (with ORANGE background)**

You **CAN** be **KILLED** or **SERIOUSLY HURT** if you don't follow instructions.



### **CAUTION (with YELLOW background)**

You **CAN** be **HURT** if you don't follow instructions.



## **BATTERY LABEL**

### **DANGER**

**CBR1000ST**

- Keep flame and spark away from the battery. Battery produce explosive gas that can cause explosion.
- Wear the eye protection and rubber gloves when handling the battery, or you can get burned or lose your eyesight by the battery electrolyte.
- Do not allow children and other people to touch a battery unless they understand proper handling and hazards of the battery very well.
- Handle the battery electrolyte with extreme care as it contains dilute sulfuric acid. Contact with your skin or eyes can burn you or cause loss of your eyesight.
- Read this manual carefully and understand it before handling the battery. Neglect of the instructions can cause personal injury and damage to the vehicle.
- Do not use a battery with the electrolyte at or below the lower level mark. It can explode causing serious injury.

**BATTERY LABEL****DANGER****CBR1000SP**

- Do not dismantle, modify or solder the main unit and battery terminals.  
Doing so may cause leakage, heat generation, explosion, fire or loss of vision due to leaked electrolyte.  
If electrolyte gets into one's eye, immediately wash the eye with plenty of water, and receive treatment from an eye specialist (ophthalmologist) as soon as possible.
- Keep this product away from fires and high temperature heat sources.  
Do not bring or cause fires (matches, lighters, cigarettes, sparks at terminals or from welding machines or grinders) close to the battery.  
Doing so may cause heat generation, explosion or fire.
- Carefully read this manual.  
If this product is handled incorrectly, it may lead to damage to the vehicle, heat generation, explosion, fire, loss of vision or burns.



## RADIATOR CAP LABEL DANGER

NEVER OPEN WHEN HOT.

Hot coolant will scald you.

Relief pressure valve begins to open at **1.1 kgf/cm<sup>2</sup>**.

## ACCESSORIES AND LOADING WARNING LABEL WARNING

ED, II ED type

ACCESSORIES AND LOADING



- The safety stability and handling of this vehicle may be affected by the addition of accessories and luggage.
- Read carefully the instructions contained in user's manual and installation guide before installing any accessory.
- The total weight of accessories and luggage added to rider's and passenger's weight should not exceed **180 kg (397 lb)**, which is the maximum weight capacity.
- The luggage weight must not exceed **14 kg (31 lb)** under any circumstances.
- The fitting of large fork-mounted or large handlebar mounted fairing is not recommended.

**REAR CUSHION LABEL****CBR1000ST**

GAS FILLED

Do not open. Do not heat.

**TYRE INFORMATION & DRIVE CHAIN LABEL**

Cold tyre pressure:

[Driver only]

Front **250 kPa (2.50 kgf/cm<sup>2</sup>, 36 psi)**Rear **290 kPa (2.90 kgf/cm<sup>2</sup>, 42 psi)**

[Driver and passenger]

Front **250 kPa (2.50 kgf/cm<sup>2</sup>, 36 psi)**Rear **290 kPa (2.90 kgf/cm<sup>2</sup>, 42 psi)**

Keep chain adjusted and lubricated.

Freeplay **25 - 35 mm (1.0 - 1.4 in)**

**ED, II ED type**



**SAFETY REMINDER LABEL**

For your protection, always wear helmet, protective apparel.

**FUEL LABEL**

**ED, II ED, U, II U type**

Unleaded petrol only

ETHANOL up to 10 % by volume

Research Octane Number (RON) 95 or higher

**II GS type**

Unleaded petrol only

ETHANOL up to 10 % by volume

Premium Recommended

**U, II U type**



**II GS type**





## Safety Precautions

- Ride cautiously and keep your hands on the handlebars and feet on the footpegs.
- Keep passenger's hands onto the seat strap or your waist, passenger's feet on the footpegs while riding.
- Always consider the safety of your passenger, as well as other drivers and riders.

### Protective Apparel

Make sure that you and any passenger are wearing an approved helmet, eye protection, and high-visibility protective clothing. Avoid wearing loose clothes that could get caught on any part of the vehicle. Ride defensively in response to weather and road conditions.

### Helmet

Safety-standard certified, high-visibility, correct size for your head

- Must fit comfortably but securely, with the chin strap fastened.
- Face shield with unobstructed field of vision or other approved eye protection

### **WARNING**

Not wearing a helmet increases the chance of serious injury or death in a crash.

Make sure that you and any passenger always wear an approved helmet and protective apparel.

## Safety Precautions

### ■ **Gloves**

Full-finger leather gloves with high abrasion resistance

### ■ **Boots or Riding Shoes**

Sturdy boots with non-slip soles and ankle protection

### ■ **Jacket and Trousers**

Protective, highly visible, long-sleeved jacket and durable trousers for riding (or a protective suit)

## Riding Precautions

### Running-in Period

During the first 500 km (300 miles) of running, follow these guidelines to ensure your vehicle's future reliability and performance.

- Avoid full-throttle starts and rapid acceleration.
- Avoid hard braking and rapid down-shifts.
- Ride conservatively.

### Brakes

Observe the following guidelines:

- Avoid excessively hard braking and downshifting.
  - ▶ Sudden braking can reduce the vehicle's stability.
  - ▶ Where possible, reduce speed before turning; otherwise you risk sliding out.

- Exercise caution on low traction surfaces.
  - ▶ The tyres slip more easily on such surfaces and braking distances are longer.
- Avoid continuous braking.
  - ▶ Repeated braking, such as when descending long, steep slopes can seriously overheat the brakes, reducing their effectiveness. Use engine braking with intermittent use of the brakes to reduce speed.
- For full braking effectiveness, operate both the front and rear brakes together.

### ■ Anti-lock Brake System (ABS)

This model is equipped with an Anti-lock Brake System (ABS) designed to help prevent the brakes from locking up during hard braking. The ABS functions with information provided by the IMU (Inertial Measurement Unit).

- ABS does not reduce braking distance. In certain circumstances, ABS may result in a longer stopping distance.
- ABS does not function at speeds below 6 km/h (4 mph).
- The brake lever and pedal may recoil slightly when applying the brakes. This is normal.
- Always use the recommended front/rear tyres and sprockets to ensure correct ABS operation.

### ■ Engine Braking

Engine braking helps slow your vehicle down when you release the throttle. For further slowing action, downshift to a lower gear. Use engine braking with intermittent use of the brakes to reduce speed when descending long, steep slopes.

### ■ Wet or Rainy Conditions

Road surfaces are slippery when wet, and wet brakes further reduce braking efficiency. Exercise extra caution when braking in wet conditions. If the brakes get wet, apply the brakes while riding at low speed to help them dry.

## Parking

- Park on a firm, level surface.
- If you must park on a slight incline or loose surface, park so that the vehicle cannot move or fall over.
- Make sure that high-temperature parts cannot come into contact with flammable materials.
- Do not touch the engine, muffler, brakes and other high-temperature parts until they cool down.
- To reduce the likelihood of theft, always lock the handlebars (➤ P. 102), and leave your vehicle while taking the Honda SMART Key with you.  
Deactivate the Honda SMART Key system if necessary. ➤ P. 105  
Use of an anti-theft device is also recommended.

## ■ Parking with the Side Stand

1. Stop the engine.
2. Push the side stand down.
3. Slowly lean the vehicle to the left until its weight rests on the side stand.
4. Turn the handlebars fully to the left.
  - ▶ Turning the handlebars to the right reduces stability and may cause the vehicle to fall.
5. Lock the steering. ➤ P. 102  
Then, leave your vehicle while taking the Honda SMART Key with you. Deactivate the Honda SMART Key system if necessary.  
➤ P. 105

### Refuelling and Fuel Guidelines

Follow these guidelines to protect the engine, fuel system and catalytic converter:

- Use only unleaded petrol.
- Use recommended octane number. Using lower octane petrol will result in decreased engine performance.
- Do not use fuels containing a high concentration of alcohol.  P. 238
- Do not use stale or contaminated petrol or an oil/petrol mixture.
- Avoid getting dirt or water in the fuel tank.

**Honda selectable torque control**

When the Honda selectable torque control (Torque Control) detects rear wheel spin during acceleration, the system will limit the amount of torque applied to the rear wheel based on the Torque Control level selected.

Additionally, the system eases the rapid motion during accelerating based on the Wheelie Control level selected.

Torque Control will allow some wheel spin during acceleration at the lower Torque Control levels settings. Select a level that is appropriate for your skill and riding conditions.

Torque Control does not work during deceleration and will not prevent the rear wheel from skidding due to engine braking. Do not close the throttle suddenly, especially when riding on slippery surfaces.

Torque Control may not compensate for rough road conditions or rapid throttle operation.

Always consider road and weather conditions, as well as your skills and condition, when applying throttle.

If your vehicle gets stuck in mud, snow or sand, it may be easier to free it by turning off the Torque Control temporarily.

Temporarily turning off Torque Control also may help you maintain control and balance when riding on off-road terrain.

Always use the recommended tyres and sprockets to ensure correct Torque Control operation.

## Accessories & Modifications

We strongly advise that you do not add any accessories that were not specifically designed for your vehicle by Honda or make modifications to your vehicle from its original design. Doing so can make it unsafe. Modifying your vehicle may also void your warranty and make your vehicle illegal to operate on public roads. Before deciding to install accessories on your vehicle be certain the modification is safe and legal.

### **⚠️ WARNING**

Improper accessories or modifications can cause a crash in which you can be seriously hurt or killed.

Follow all instructions in this owner's manual regarding accessories and modifications.

Do not pull a trailer with, or attach a sidecar to, your vehicle. Your vehicle was not designed for these attachments, and their use can seriously impair your vehicle's handling.



## Loading

- Carrying extra weight affects your vehicle's handling, braking and stability.  
Always ride at a safe speed for the load you are carrying.
- Avoid carrying an excessive load and keep within specified load limits.  
**Maximum weight capacity / Maximum luggage weight** ❏ P. 240
- Tie all luggage securely, evenly balanced and close to the centre of the vehicle.
- Do not place objects near the lights or the muffler.

### **⚠ WARNING**

Overloading or improper loading can cause a crash and you can be seriously hurt or killed.

Follow all load limits and other loading guidelines in this manual.

# Parts Location

CBR1000ST

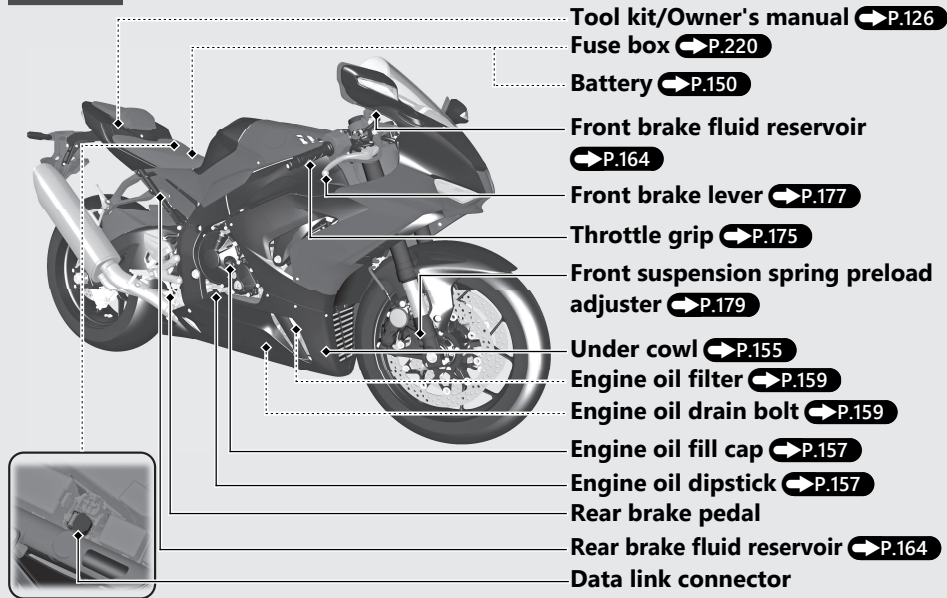

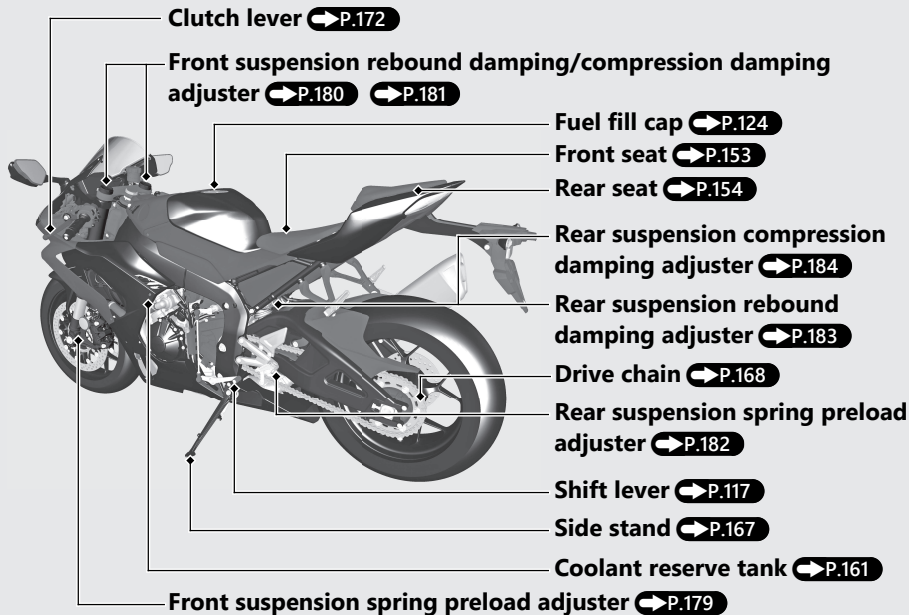

## Parts Location *(Continued)*



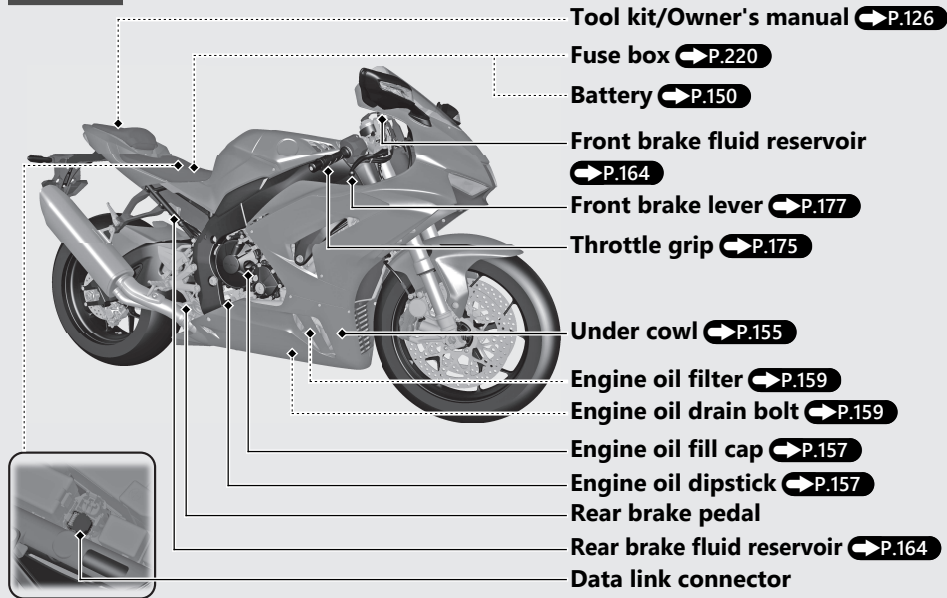

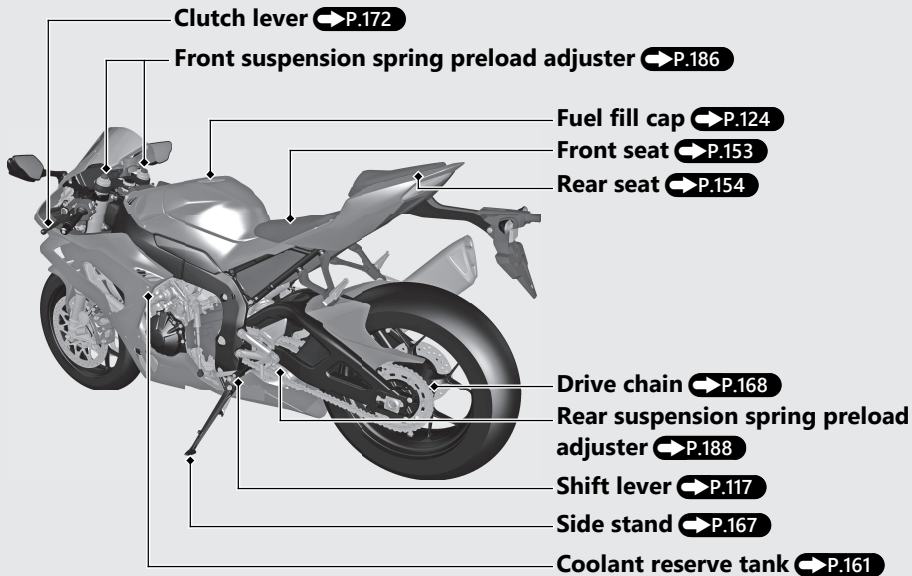
CBR1000SP







# Instruments

The display type consists of the following 5 patterns.

- ANALOG  P.27
- DIGITAL  P.28
- BAR  P.29
- NO REV  P.30
- PRACTICE  P.31

**To change the display type:**  P.63  P.75

Each display type has the SPORT mode.  P.32

The operation of the instrument is mainly explained in the ANALOG display type.

Factory default setting is ANALOG.

Do not operate the display functions for a long time with the engine stopped. It may result in a low (or dead) battery.

## STD mode display

Display type: ANALOG (Factory default setting)

 **Low oil pressure indicator**  **P.55**

**Clock**

**To set the clock:**

 **P.63**  **P.84**

**HESD (Honda Electronic Steering Damper) indicator**

 **P.55**

 **Coolant temperature gauge**  **P.51**

**INFO area**  **P.35**

**Gear position indicator**  **P.55**

**ABS mode indicator**  **P.55**

 **High beam indicator**

 **High coolant temperature indicator**  **P.55**

**Tachometer**

**NOTICE**

Do not operate the engine in the tachometer red zone. Excessive engine speed can adversely affect engine life.

**Tachometer red zone**  
(excessive engine rpm range)

**Current riding mode**  
 **P.109**

**Speedometer**

**Reserve fuel mode**  **P.49**

**Pop-up information**  **P.52**

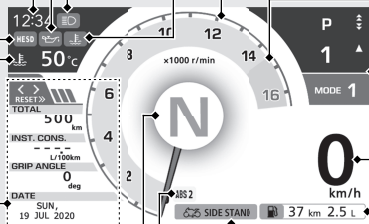

## Instruments (Continued)

Display type: DIGITAL

Pop-up information  P.52

ABS mode indicator

 P.55

 High beam indicator

Clock To set the clock:

 P.63  P.84

 Coolant temperature gauge

 P.51

Current riding mode  P.109

INFO area  P.35

Tachometer

**NOTICE**

Do not operate the engine in the tachometer red zone. Excessive engine speed can adversely affect engine life.

HESD (Honda Electronic Steering Damper) indicator  P.55

 Low oil pressure indicator  P.55

Speedometer

Tachometer red zone

(excessive engine rpm range)

 High coolant temperature indicator

 P.55

Gear position indicator

 P.55

Reserve fuel mode  P.49

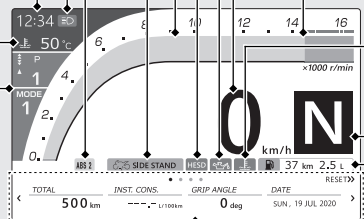



Display type: BAR

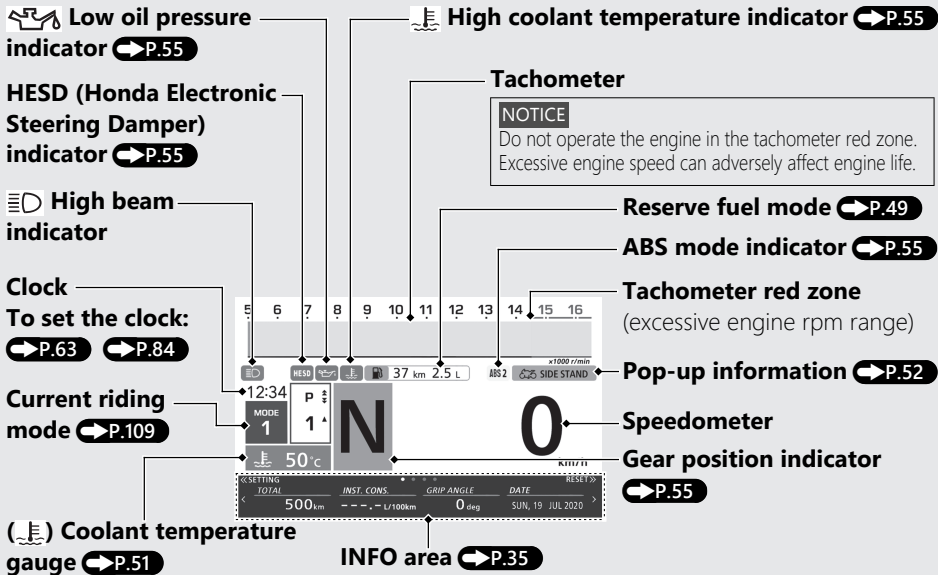

## Instruments (Continued)

Display type: NO REV

**Clock**

To set the clock:

➔ P.63 ➔ P.84

**Current riding mode**

➔ P.109

 **Coolant temperature gauge** ➔ P.51

**HESD (Honda Electronic Steering Damper) indicator** ➔ P.55

 **Low oil pressure indicator** ➔ P.55

 **High coolant temperature indicator** ➔ P.55

**ABS mode indicator** ➔ P.55

**Gear position indicator** ➔ P.55

**Reserve fuel mode**

➔ P.49

**Speedometer**

 **High beam indicator**

**INFO area** ➔ P.35

**Pop-up information** ➔ P.52

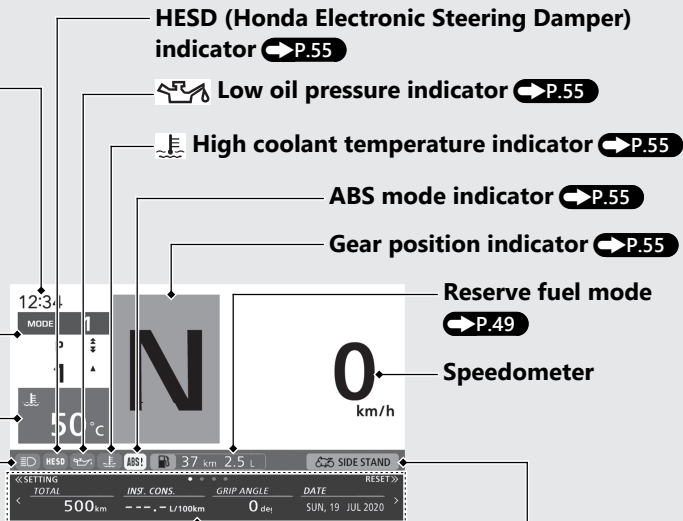

The tachometer is not displayed when NO REV is selected.

Display type: PRACTICE

**Reserve fuel mode** ➔ P.49

**Tachometer**

**NOTICE**  
Do not operate the engine in the tachometer red zone. Excessive engine speed can adversely affect engine life.

**Current riding mode** ➔ P.109

**Equalizer** ➔ P.48

**Clock**

**To set the clock:**

➔ P.63 ➔ P.84

**ABS mode indicator**

➔ P.55

**Pop-up information** ➔ P.52

**INFO area** ➔ P.35

 **High beam indicator**

**HESD (Honda Electronic Steering Damper) indicator** ➔ P.55

 **Low oil pressure indicator** ➔ P.55

**Tachometer red zone**  
(excessive engine rpm range)

 **High coolant temperature indicator** ➔ P.55

 **Coolant temperature gauge** ➔ P.51

**Speedometer**

**Gear position indicator** ➔ P.55

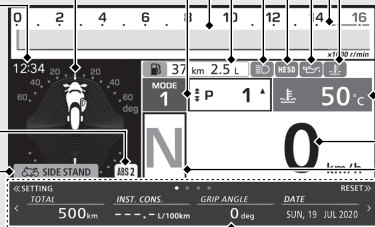

## Instruments (Continued)

### SPORT mode display

**To change to the SPORT mode display:** Set the "LAP" to "ON" in setting mode. P.63

P.75

▶ To return to the STD mode display, set the "LAP" to "OFF" in setting mode.

When switching to SPORT mode display, the following message appears on the screen for a few seconds then the lap timer is displayed.

When in the SPORT mode, the PASSING/LAP switch functions as a LAP switch.

▶ If the SPORT mode has been set, this message will also appear when the electrical system is turned on.

**Lap timer** P.57



**Display type:**  
**ANALOG**



**Display type:**  
**DIGITAL**



**Display type:**  
**BAR**



**Display type:**  
**NO REV**



**Display type:**  
**PRACTICE**

## Basic Operations

You can operate and set the various functions of the display using the switches on the left handlebar.

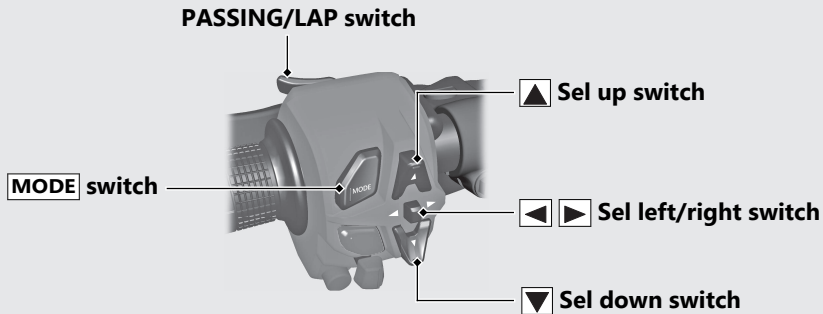

## Instruments (Continued)

When switching or setting the display, refer to the switch operation guide is displayed.

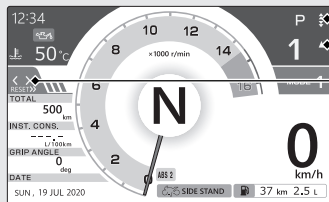

Switch operation guide

Type of the switch operation guide:

- ▲ or ^ : Press the ▲ sel up switch
- ▼ or v : Press the ▼ sel down switch
- < : Push the ◀ of the ◀ ▶ sel left/right switch
- > : Push the ▶ of the ◀ ▶ sel left/right switch
- ▲ or ⤴ : Press and hold the ▲ sel up switch
- ▼ or ⤵ : Press and hold the ▼ sel down switch
- ◀◀ : Push and hold the ◀ of the ◀ ▶ sel left/right switch
- ▶▶ : Push and hold the ▶ of the ◀ ▶ sel left/right switch

## INFO area

### To switch the INFO area

To change the page of the INFO area, push the ◀ ▶ sel left/right switch.

You can change the information items to be displayed on the pages 1-3 (INFO 1-3).

You can also change the number of items to be displayed in the information area.

**To select the FAVORITE INFORMATION** ◀ P.63 ▶ P.81

**To change the number of information items are displayed** ▶ P.63 ▶ P.75

Page 4 displays the current riding mode settings.

**Riding mode** ▶ P.109

**Quick Shifter indicator** ▶ P.56

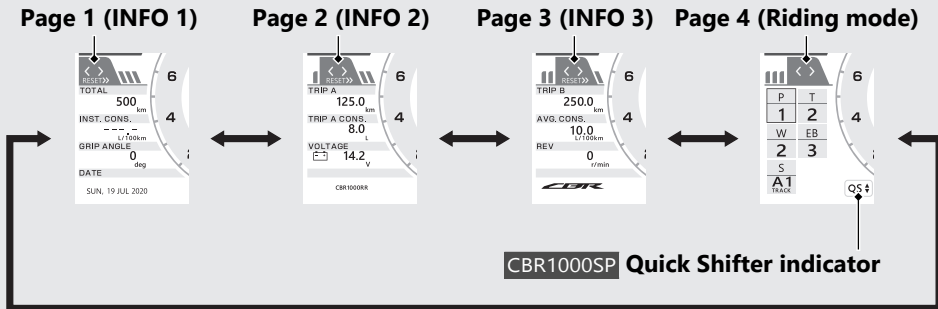

## Instruments *(Continued)*

The following items are types of information that can be displayed on pages 1-3 (INFO 1-3).

TOTAL → P.37

TRIP A → P.37

TRIP A CONS. → P.38

TRIP B → P.37

INST. CONS. → P.38

AVG. CONS. → P.39

AVG. SPD. → P.39

ELAPSED → P.40

REV → P.40

GRIP ANGLE → P.40

VOLTAGE → P.41

DATE → P.41

User letter → P.41

CBR logo → P.41

SHIFT POINT → P.42

LAP CONS. → P.42

LAP AVG. CONS. → P.43

LAP AVG. SPD. → P.43

MAX ACC. → P.44

MAX DEC. → P.44

MAX LEAN ANGLE R → P.44

MAX LEAN ANGLE L → P.44

FUEL CONS. → P.45

AVG. CONS. |→ P.45

AVG. SPD. |→ P.46

ELAPSED |→ P.46

Blank → P.47



## Odometer [TOTAL]

Total distance ridden.

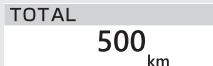

When "-----" is displayed, go to your dealer for service.

## Tripmeter A/B [TRIP A/B]

Distance ridden since the tripmeter was reset.



When "----.-" is displayed, go to your dealer for service.

**To reset the tripmeter:**  **P.47**

## Instruments *(Continued)*

### Tripmeter A fuel consumption [TRIP A CONS.]

Displays the tripmeter A fuel consumption since the tripmeter A was reset.

Display range: 0.0 to 299.9 L (litres) or 0.0 to 299.9 GAL (gallon)

- Above 299 L (litres) or 299 GAL (gallon): "299.9" is displayed.
- When the tripmeter A fuel consumption is reset: "0.0" is displayed.



When "---.-" is displayed go to your dealer for service.

Tripmeter A fuel consumption is reset when you reset tripmeter A.

**To reset the tripmeter A:**  **P.47**

### Current fuel mileage [INST. CONS.]

Displays the current instant fuel mileage.

Display range: 0.0 to 299.9 L/100km (km/L, mile/gal or mile/L)

- When your speed is less than 7 km/h (5 mph): "---.-" is displayed.
- Below 0.1 L/100km (km/L, mile/gal or mile/L): "0.0" is displayed.
- Above 299.9 L/100km (km/L, mile/gal or mile/L): "299.9" is displayed.



When "---.-" is displayed except for the above-mentioned cases, go to your dealer for service.

### Average fuel mileage [AVG. CONS.]

Displays the average fuel mileage since the average fuel mileage was reset.

Display range: 0.0 to 299.9 L/100km (km/L, mile/gal or mile/L)

- Below 0.1 L/100km: "---.-" is displayed.
- Below 0.1 km/L (mile/gal or mile/L): "0.0" is displayed.
- Above 299.9 L/100km (km/L, mile/gal or mile/L): "299.9" is displayed.
- When the average fuel mileage is reset: "---.-" is displayed.

AVG. CONS.

10.0  
L/100km

When "---.-" is displayed except for the above-mentioned cases, go to your dealer for service.

### To reset the average fuel mileage

➡ P.47

### Average speed [AVG. SPD.]

Displays the average speed since the average speed was reset.

Display range: 0 to 350 km/h (0 to 218 mph)

- Initial display: "---" is displayed.
- When your vehicle has traveled less than 0.2 km (0.12 mile) since the engine was started: "---" is displayed.
- When your vehicle operating time is less than 16 seconds since the engine was started: "---" is displayed.

AVG. SPD.

60  
km/h

When "---" is displayed except for the above-mentioned cases, go to your dealer for service.

### To reset the average speed ➡ P.47

## Instruments *(Continued)*

### Elapsed time [ELAPSED]

Displays the engine operating time since the elapsed time was reset.

Display range: 00:00 to 99:59 (hours:minutes)

- Above 99:59: back to 00:00

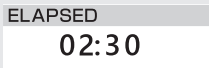

When "--:--" is displayed, go to your dealer for service.

**To reset the elapsed time**  **P.47**

### Numerical tachometer display [REV]

Displays the engine revolutions per minutes.

Display range: 0 to 16,500 r/min

Above 16,500 r/min (rpm): "16500" is displayed.



### Throttle grip angle [GRIP ANGLE]

Displays the throttle grip angle during operation.

Display range: 0 to 90 deg



When "--" is displayed, go to your dealer for service.

**Battery voltage [VOLTAGE]**

Displays the current voltage.

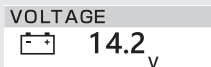
**Date [DATE]**

Show the date of today.

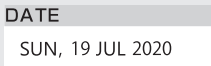

Display range:

Day of the week: MON to SUN

DAY: 1 to 31

MONTH: JAN to DEC

YEAR: 2019 to 2119

**To set the date:** P.63 P.84

**User letter**

Displays the characters of user's choice.



**To set the USER LETTER:** P.63 P.82

**CBR logo**

Displays the CBR logo.



## Instruments *(Continued)*

### Shift indicator set value [SHIFT POINT]

Displays the shift indicator set value.

Display range: 5,000 - 16,500 r/min

- When the brightness setting of the REV INDICATOR is selected to off: "-----" is displayed.
- When the gear position is neutral (N) or 6th: "-----" is displayed.

SHIFT POINT
14500 r/min

To set the shift indicator:  P.63  P.73

### Lap fuel consumption [LAP CONS.]

Displays the fuel consumption of the latest lap.

Display range: 0.0 to 50.0 L (litres) or 0.0 to 50.0 GAL (gallon)

- Above 50 L (litres) or 50 GAL (gallon): "50.0" is displayed.
- Below 0.1 L (0.1 GAL): "0.0" is displayed.
- When there is no lap data: "--.-" is displayed.

LAP CONS.
0.8 L

When "--.-" is displayed except for the above-mentioned cases, go to your dealer for service.

### Lap average fuel mileage [LAP AVG. CONS.]

Displays the average fuel mileage of the latest lap.

Display range: 0.0 to 299.9 L/100km (km/L, mile/gal or mile/L)

- Below 0.1 L/100km: "---.-" is displayed.
- Below 0.1 km/L (mile/gal or mile/L): "0.0" is displayed.
- Above 299.9 L/100km (km/L, mile/gal or mile/L): "299.9" is displayed.
- When there is no lap data: "---.-" is displayed.

LAP AVG. CONS.

**7.2**  
L/100km

When "---.-" is displayed except for the above-mentioned cases, go to your dealer for service.

### Lap average speed [LAP AVG. SPD.]

Displays the average speed of the latest lap.  
Display range: 0 to 350 km/h (0 to 218 mph)

- When there is no lap data: "---" is displayed.

LAP AVG. SPD.

**120**  
km/h

When "---" is displayed except for the above-mentioned cases, go to your dealer for service.

## Instruments *(Continued)*

### Maximum acceleration in this time [MAX ACC.]

Displays the maximum acceleration since the engine was started.

Display range: 0 to 1.5 G

- Until detects the acceleration: "--" is displayed.

MAX ACC.  
0.5  
G

### Maximum deceleration in this time [MAX DEC.]

Displays the maximum deceleration since the engine was started.

Display range: 0 to 1.5 G

- Until detects the deceleration: "--" is displayed.

MAX DEC.  
0.4  
G

### Maximum right lean angle in this time [MAX LEAN ANGLE R]

Displays the maximum lean angle of right side since the engine was started.

Display range: 0 to 60 deg

- Until detects the lean angle: "--" is displayed.

MAX LEAN ANGLE R  
30  
deg

### Maximum left lean angle in this time [MAX LEAN ANGLE L]

Displays the maximum lean angle of left side since the engine was started.

Display range: 0 to 60 deg

- Until detects the lean angle: "--" is displayed.

MAX LEAN ANGLE L  
32  
deg



### Fuel consumption in this time [FUEL CONS.]

Displays the fuel consumption since the engine was started.

Display range: 0.0 to 50.0 L (litres) or 0.0 to 50.0 GAL (gallon).

- Below 0.04 L (0.04 GAL): "0.0" is displayed.
- Above 50 L (litres) or 50 GAL (gallon): "50.0" is displayed.
- Until detects the fuel consumption: "--.-" is displayed.

FUEL CONS.
2.5 L

When "--.-" is displayed except for the above-mentioned cases, go to your dealer for service.

### Average fuel mileage in this time [AVG. CONS. ]→

Displays the average fuel mileage since the engine was started.

Display range: 0.0 to 299.9 L/100km (km/L, mile/gal or mile/L).

- Below 0.1 L/100km: "---.-" is displayed.
- Below 0.1 km/L (mile/gal or mile/L): "0.0" is displayed.
- Above 299.9 L/100km (km/L, mile/gal or mile/L): "299.9" is displayed.
- Until detects the fuel mileage: "---.-" is displayed.

AVG. CONS. ]→
4.9 L/100km

When "---.-" is displayed except for the above-mentioned cases, go to your dealer for service.

## Instruments *(Continued)*

### Average speed in this time [AVG. SPD.]



Displays the average speed since the engine was started.

Display range: 0 to 350 km/h (0 to 218 mph).

- Initial display: "---" is displayed.
- When your vehicle has traveled less than 0.2 km (0.12 mile) since the engine was started: "---" is displayed.
- When your vehicle operating time is less than 16 seconds since the engine was started: "---" is displayed.

AVG. SPD.

**80**  
km/h

When "---" is displayed except for the above-mentioned cases, go to your dealer for service.

### Elapsed time in this time [ELAPSED

Displays the engine operating time since the engine was started.

Display range: 00:00 to 99:59 (hours:minutes)

- Above 99:59: back to 00:00.
- Until detects the elapsed time: "--:--" is displayed.

When the electrical system is turned off, the elapsed time is reset.

ELAPSED

**01:30**

When "--:--" is displayed except for the above-mentioned cases, go to your dealer for service.

## Blank display

Display the blank.

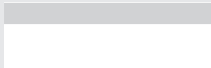

### To Reset the Information

Select the page (INFO1, 2, 3) of INFO area that contains the item you want to reset with the ◀ ▶ sel left/right switch.

Push and hold the ▶ of the ◀ ▶ sel left/right switch until the RESET turns to red.

- ▶ If there are no items on the page that can be reset, there is no response to the operation.

Select the item with the ◀ ▶ sel left/right switch.

- ▶ If the display type is ANALOG, select the item with ▲ sel up switch or ▼ sel down switch.

Push and hold the ▶ of the ◀ ▶ sel left/right switch until the item is reset.

To exit the reset mode, push and hold the ◀ of the ◀ ▶ sel left/right switch.

## Instruments *(Continued)*

### EQUALIZER

Displays the current lean angle of left/right side.

Displays the current acceleration/ deceleration.

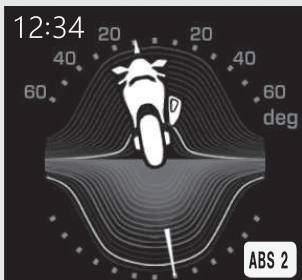

## Reserve Fuel Mode

When the low fuel indicator appears the available driving distance and amount of remaining fuel displayed. You should refill the tank as soon as possible.

Remaining fuel amount turned to the reserve fuel mode: 3.5 L (0.9 US gal, 0.7 Imp gal)

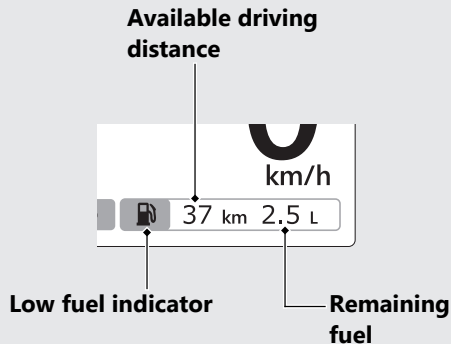

After refuelling more than the reserve amount, the display returns to normal when the electrical system has been on for about a minute.

## Instruments *(Continued)*

### Available driving distance (Only reserve fuel mode)

When the low fuel indicator lights, the estimated available driving distance is indicated.

Display range: 99 to 5 km (mile)

- Above 99 km (mile): "99" is displayed.
- Below 5 km (mile): "--" is displayed.
- Below 1.0 L (0.2 GAL): "--" is displayed.
- Until detects the available driving distance: "--" is displayed.

The indicated available driving distance is calculated based on the driving states, and the indicated figure may not always be the actual allowable distance.

When "--" is displayed except for the above-mentioned cases, go to your dealer for service.

### Amount of remaining fuel (Only reserve fuel mode)

When the low fuel indicator lights, the estimated amount of remaining fuel can be selected.

Display range: 3.5 to 1.0 L (litres) or 0.7 to 0.2 GAL (gallon)

- Below 1.0 L (0.2 GAL): "-.-" is displayed.
- Until detects the amount of remaining fuel: "-.-" is displayed.

The amount of remaining fuel is calculated based on the driving states. The indicated amount of remaining fuel may be different from the actual amount.

When "-.-" is displayed except for the above-mentioned cases, go to your dealer for service.

## Coolant temperature gauge ( )

Display range: 35°C to 132°C

- 34°C or less: "---" is displayed.
- Between 122°C and 131°C:
  - High coolant temperature indicator lights.
  - Coolant temperature digits flash.
- Above 132°C:
  - High coolant temperature indicator lights.
  - "132°C" flashes.
- Even if the engine coolant temperature is low, the cooling fan may start running when you rev up the engine. This is normal.

## Instruments *(Continued)*

### Pop-up information







In the following cases, pop-up information is displayed.

- Maintenance information:  
When the inspection time of your vehicle is approaching.
- Helpful information:  
When your vehicle has helpful information.
- Start mode Information:  
When in the start mode.
- Failure information:  
**CBR1000SP**  
When your vehicle has a problem with the ÖHLINS Smart EC system.

When your vehicle has multiple pieces of information, the high-priority pop-up information display will appear.



If the priorities are the same, pop-up information display appears alternately.

The priority order is as follows:



Priority	Pop-up information items
1	
2	
3	<b>START MODE</b>
4	 <div style="display: flex; justify-content: space-between;"> <div style="text-align: center;">  SIDE STAND         </div> <div style="text-align: center;">  100 km JUL/2020         </div> </div> <div style="text-align: center; margin-top: 5px;">  500 km JUL/2020         </div>



## Maintenance Information

Indication	Explanation	Remedy
 500 km JUL/2020	When the periodic inspection time of your vehicle is approaching.	Have your vehicle inspected by your dealer.
 100 km JUL/2020	When the oil change time of your vehicle is approaching.	Change the engine oil.  <b>P.159</b>

## Helpful Information

Indication	Explanation	Remedy
 SIDE STAND	When the side stand is down.	Raise the side stand.
	<b>CBR1000SP</b> When the suspension initialization is waiting.	Stop your vehicle. Wait for a few seconds until the indication turns off. If the indication dose not turns off, contact your dealer.

## Instruments *(Continued)*

### Start Mode Information

Indication	Explanation	Remedy
START MODE	When the background colour is: Orange: Start mode is allowed. Green: Limiting the engine revolution. Gray: Start mode is not allowed.	To use the start mode → P.63 → P.74 → P.119

### Failure Information

Indication	Explanation	Remedy
	<b>CBR1000SP</b> When your vehicle has a problem with the ÖHLINS Smart EC system.	Reduce speed and have your vehicle inspected by your dealer as soon as possible.

## Gear position indicator

The gear position is shown in the gear position indicator.

- ▶ "-" appears when the transmission is not shifted properly.

## ABS mode indicator [ABS 1/2]

Displays the current ABS mode.

ABS 1 is suitable for track riding.

ABS 2 is suitable for street riding or winding roads.

When the indicator flashes, go to your dealer for service.

**To select the ABS mode:**  **P.63**

 **P.72**



## Low oil pressure indicator

- Comes on when the electrical system is turned on.
- Goes off when the engine starts.

**If it comes on while engine is running:**

 **P.198**

## HESD (Honda Electronic Steering Damper) indicator

**If it comes on while engine is running:**

 **P.199**



## High coolant temperature indicator

**If it comes on while riding:**  **P.197**





## Instruments *(Continued)*

### Quick Shifter indicator

CBR1000SP

Displays the current status of the Quick Shifter.

This indicator is displayed when the INFO area is in page 4 (Riding mode).

-  Quick Shifter system is disabled.
-  Quick Shifter upshifting is enabled.
-  Quick Shifter downshifting is enabled.
-  Quick Shifter upshifting and downshifting are both enabled.



**QUICK SHIFTER:**  **P.63**  **P.70**  **P.118**

## Lap Timer

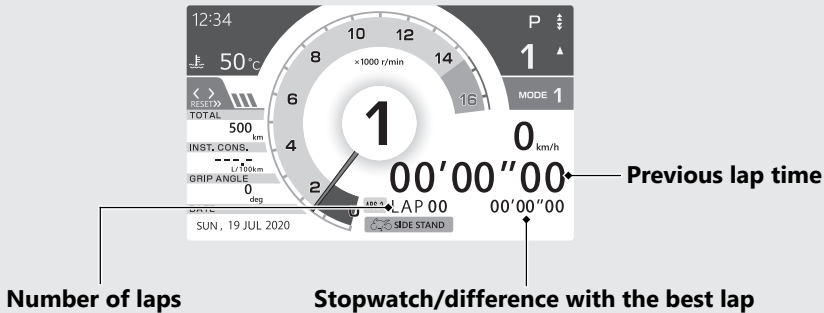
You can record lap time in the SPORT mode. P.63 P.75



## Instruments *(Continued)*

You can check and clear the recorded lap data in the setting mode.  

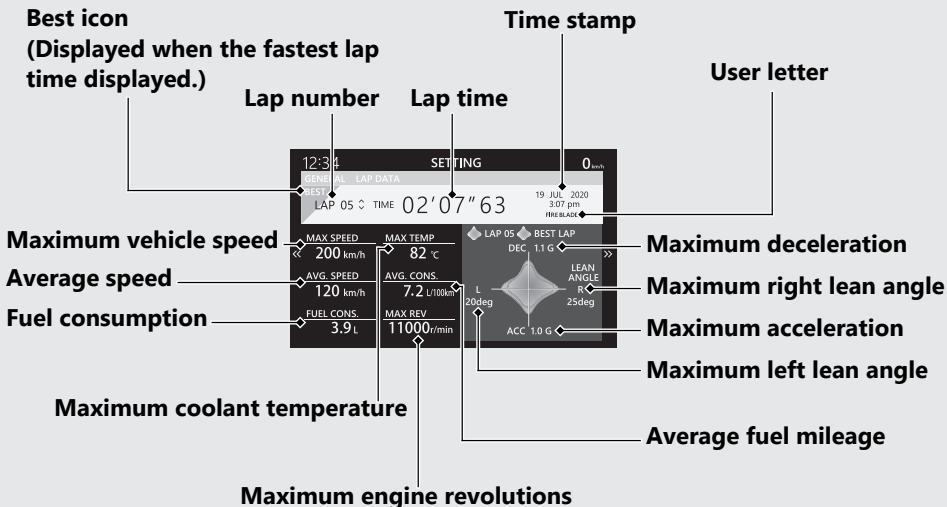

The lap data include the following:

<b>Lap data</b>	<b>Display range</b>
Previous lap number	0 to 99 ▶ Exceeds 99, repeats the "99"
Previous lap time	00'00"00 to 99'59"99
Stopwatch	00'00"00 to 99'59"99
Difference with the best lap	-99'59"99 to 00'00"00 to +99'59"99
Maximum vehicle speed	0 to 350 km/h (0 to 218 mph)
Average speed	0 to 350 km/h (0 to 218 mph)
Fuel consumption	0.0 to 299.9 L (litres) or 0.0 to 299.9 GAL (gallon)
Maximum coolant temperature	35 to 132°C
Average fuel mileage	0.0 to 299.9 L/100km (km/L, mile/gal or mile/L)
Maximum engine revolutions	0 to 16500 r/min (rpm)
Maximum acceleration	0 to 1.5 G
Maximum deceleration	0 to 1.5 G
Maximum right lean angle	0 to 60 deg
Maximum left lean angle	0 to 60 deg

## Instruments (Continued)

### To Measure the Lap Time

- 1 Set the "LAP" to "ON" in setting mode.  
 ➔ P.63   ➔ P.75
- 2 To start measuring, press the PASSING/LAP switch.  
 ▶ The stopwatch starts measurement.

**PASSING/LAP  
switch**

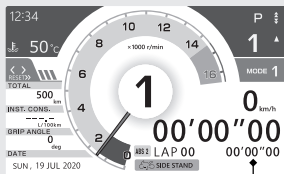
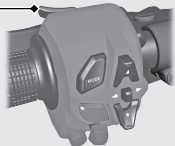

**Stopwatch**

- 3 To record lap time, press the PASSING/LAP switch at each lap.
  - ▶ The stopwatch changes to display of the difference with the best lap. After 10 seconds, the display will return to the stopwatch.
  - ▶ The previous lap time and previous lap number change to the information of the previous lap.
  - ▶ If you press the PASSING/LAP switch again within 10 seconds, lap time is not recorded.
  - ▶ When exceeds 99 lap, the previous lap number repeats the "LAP 99".



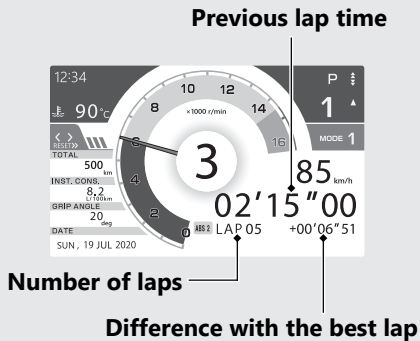

- 4 To end measurement, press and hold the PASSING/LAP switch.

### To restart the measurement

Press the PASSING/LAP switch again. The stopwatch restarts measurement.

- ▶ Measurement starts from the next lap.

### To Check or Clear the Lap Time

Select the "LAP DATA" menu in the setting mode. ➡P.63 ➡P.83

## Instruments (Continued)

### Setting mode

#### To shift to the setting mode

Push and hold the ◀ of the ◀ ▶ sel left/right switch.

To select the desired setting menu, operate the ▲ sel up switch, ▼ sel down switch, ◀ ▶ sel left/right switch on the left handle.

- ▶ When switching to setting mode, the clock, indicator and speed are displayed at the top of the screen.

#### Ordinary display

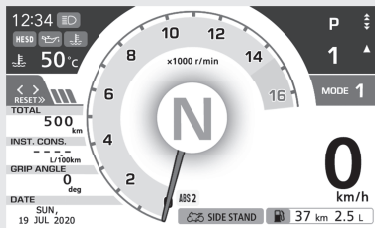

#### Setting mode

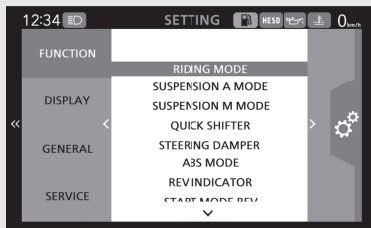

#### To complete the setting:

- Push and hold the ◀ of the ◀ ▶ sel left/right switch, return to the upper hierarchy.
- Push and hold the **MODE** switch, return to the ordinal display.

## Setting flow

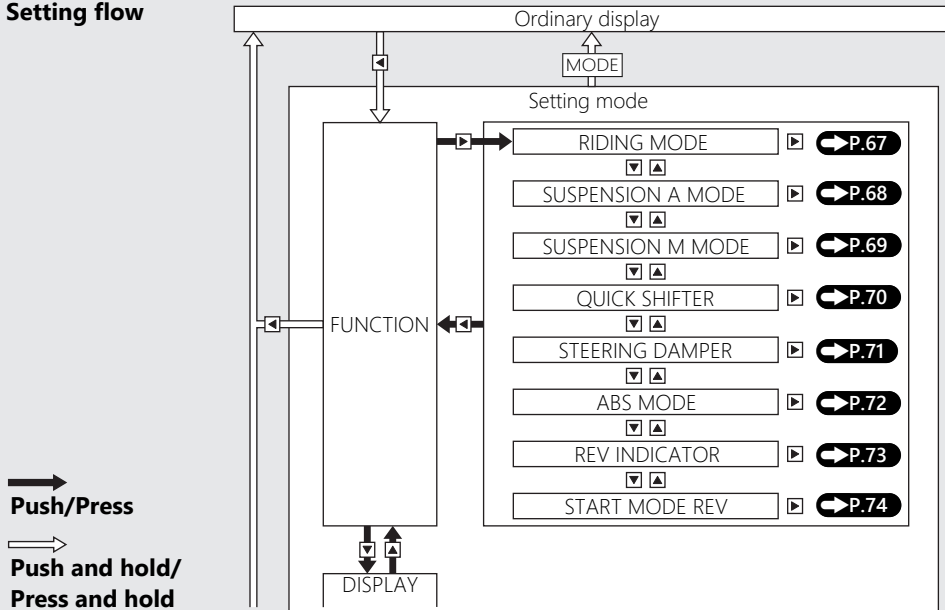

## Instruments (Continued)

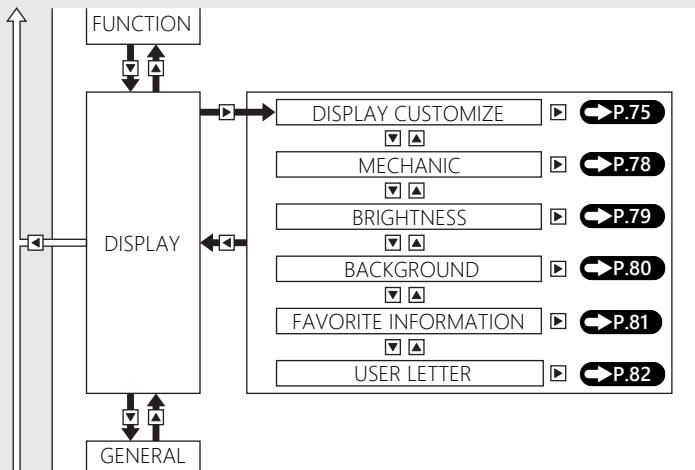

 **Push/Press**

 **Push and hold/  
Press and hold**

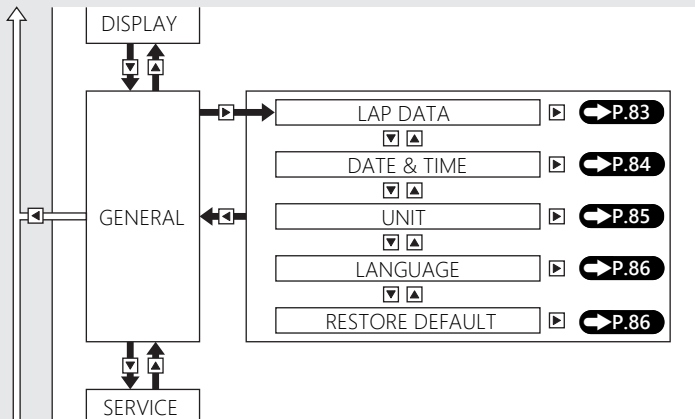

 **Push/Press**

 **Push and hold/  
Press and hold**

## Instruments *(Continued)*

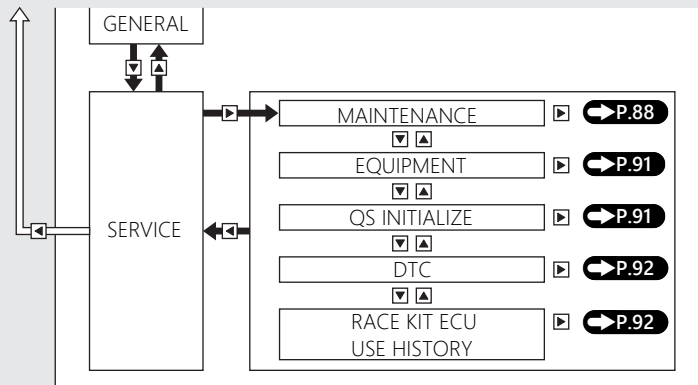

  
**Push/Press**

  
**Push and hold/  
Press and hold**

## RIDING MODE P.109

You can select the RIDING MODE.

- 1 Select the "MODE 1", "MODE 2" or "MODE 3" using the sel up or sel down switch.
- 2 Select to the desired setting according to the switch operation guide.
  - ▶ **CBR1000ST**  
"S" (suspension mode) is not displayed.
- 3 Return to the ordinary display or upper hierarchy to complete the setting.

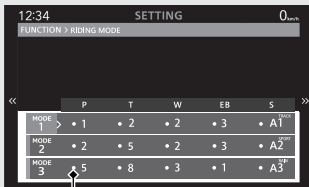

**Default setting mark**

## To return to the initialize settings:

- 1 Push and hold the of the sel left/right switch.
- 2 Reset the setting according to the switch operation guide.



## Instruments (Continued)





### SUSPENSION A MODE P.189

#### CBR1000SP

You can change the levels of OBTi support items.

### Adjusting the ÖHLINS Smart EC system

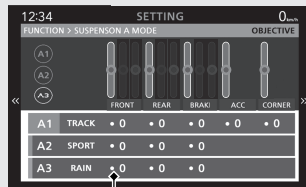

#### P.185

- 1 Select the "A 1", "A 2" or "A 3" using the  sel up or  sel down switch.
- 2 Push the  of the   sel left/right switch.
- 3 Select to the desired setting according to the switch operation guide.
  - ▶ When you select the "TRACK", you can select the "ACC" and "CORNER" levels.
- 4 Return to the ordinary display or upper hierarchy to complete the setting.



### Default setting mark

### To return to the initialize settings:

- 1 Push and hold the  of the   sel left/right switch.
- 2 Reset the setting according to the switch operation guide.







## SUSPENSION M MODE P.192

CBR1000SP

You can adjust the compression and rebound damping of the front and rear suspension electronically.

### Adjusting the ÖHLINS Smart EC system

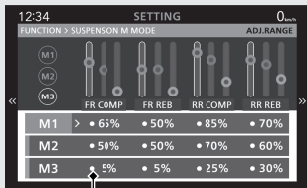

 P.185

- 1 Select the "M 1", "M 2" or "M 3" using the  sel up or  sel down switch.
- 2 Select to the desired setting according to the switch operation guide.
- 3 Return to the ordinary display or upper hierarchy to complete the setting.



Default setting mark

### To return to the initialize settings:

- 1 Push and hold the  of the   sel left/right switch.
- 2 Reset the setting according to the switch operation guide.



## Instruments *(Continued)*

### QUICK SHIFTER

#### CBR1000SP

You can change the setting of the Quick Shifter.



UP: Change the setting for upshifting.

DOWN: Change the setting for downshifting.

OFF	Deactivate
SOFT	Activate
MEDIUM	
HARD	

SOFT, MEDIUM or HARD indicate the load level of the shift pedal.

**To use the Quick Shifter:**  P.118

- 1 Select the "UP" or "DOWN" using the  sel up or  sel down switch.
- 2 Select to the desired setting according to the switch operation guide.
- 3 Return to the ordinary display or upper hierarchy to complete the setting.

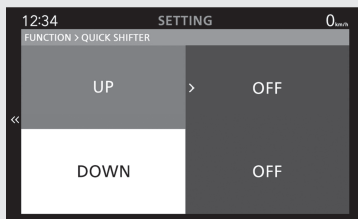

## STEERING DAMPER

You can change the damping level of the steering damper.

The steering damping level can be selected from "SOFT", "MEDIUM" or "HARD".

Each level's characteristics

SOFT: More agile steering feel. (Default setting level)

MEDIUM: Medium steering damping level between "SOFT" and "HARD".

HARD: More stable steering feel on high speed riding.

- 1 Select the steering damping level from "SOFT", "MEDIUM" or "HARD" using the ▲ sel up or ▼ sel down switch.
- 2 Return to the ordinary display or upper hierarchy to complete the setting.
  - ▶ You can also complete the setting by pressing the ◀ of the ◀ ▶ sel left/right switch.

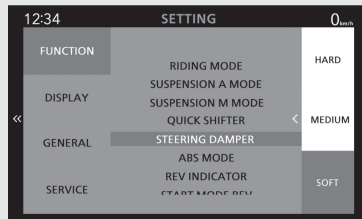

## Instruments *(Continued)*

### ABS MODE

You can change the ABS mode.

The ABS mode can be selected from the "ABS1 (TRACK)" or "ABS2 (SPORT)".

- 1 Select the "ABS1 (TRACK)" or "ABS2 (SPORT)" using the ▲ sel up or ▼ sel down switch.
- 2 Return to the ordinary display or upper hierarchy to complete the setting.
  - ▶ You can also complete the setting by pressing the ◀ of the ◀ ▶ sel left/right switch.

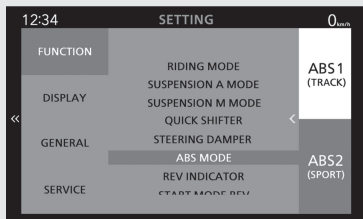

## REV INDICATOR

You can change the setting of the shift indicators.

### INTERVAL

You can adjust the interval of lighting the shift indicator.

- ▶ Available setting range: 0 - 500 r/min (rpm)

### SHIFT POINT

You can adjust the shift point.

- ▶ When "FOR EACH GEAR" is selected, the gear position number is displayed, and the shift point can be selected for each gear.



- ▶ Available setting range: 5,000 - 16,500 r/min (rpm)

## BRIGHTNESS

You can adjust the shift indicator brightness.

- ▶ Available setting range: OFF or 1 - 8
- ▶ When "OFF" is selected, the shift indicator is deactivated.

- 1 Select the "INTERVAL", "SHIFT POINT" or "BRIGHTNESS" using the ▲ sel up or ▼ sel down switch.
- 2 Select to the desired setting according to the switch operation guide.
- 3 Return to the ordinary display or upper hierarchy to complete the setting.

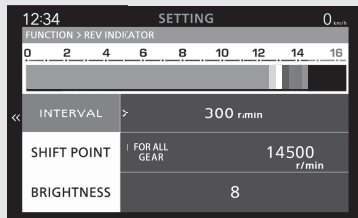

## Information of the Shift Indicator:

➔ P.96

## Instruments *(Continued)*

### START MODE REV

You can change the engine revolutions when using the start mode.

**To use the start mode:** ➡ P.119

▶ Available setting range: OFF or 6,000 - 9,000 r/min (rpm)

① Select the engine revolutions using the ▲ sel up or ▼ sel down switch.

② Return to the ordinary display or upper hierarchy to complete the setting.

▶ You can also complete the setting by pressing the ◀ of the ◀ ▶ sel left/right switch.

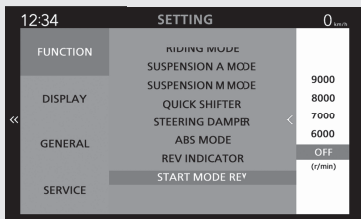

## DISPLAY CUSTOMIZE

You can register 3 patterns of display settings and use them as ordinary displays.

You can select and combine your favorite styles from "DISPLAY STYLE", "REV STYLE", "LAP" and "INFO" settings.

DISPLAY TYPE : You can change the display type.

REV STYLE : You can change the tachometer style.

LAP : You can switch between STD mode and SPORT mode.

INFO : You can change the number of items to be displayed in the information area.

### To use a registered display setting as the ordinary display:

- 1 Select the desired screen setting from the "01", "02" or "03" using the ▲ sel up or ▼ sel down switch.
- 2 Return to the ordinary display or upper hierarchy to complete the setting.
  - ▶ The date appears when you register the display settings or use the registered screen as an ordinary display.

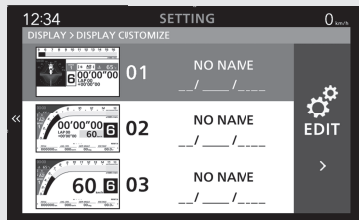

## Instruments *(Continued)*

### To edit and register the display:

- 1 Select the "EDIT" according to the switch operation guide.
- 2 Select the "DISPLAY TYPE", "REV STYLE", "LAP" or "INFO" using the ▲ sel up or ▼ sel down switch.
- 3 Select to the desired setting according to the switch operation guide.
  - ▶ You can check the current display settings with thumbnail.
  - ▶ To switch to the SPORT mode, select the "ON" from the "LAP" menu.
- 4 Return to the ordinary display or upper hierarchy to complete the setting.
  - ▶ The date appears when you register the display settings or use the registered screen as an ordinary display.

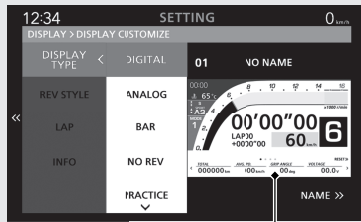







**Thumbnail**



## To edit the display name:

You can edit the display name with up to 10 characters.

- 1 Select the "EDIT" according to the switch operation guide.
- 2 Push and hold the  of the   sel left/right switch.
- 3 Edit the display name.
  - ▶ To select the character using the  sel up switch,  sel down switch, and  sel left/right switch.
  - ▶ To set the character using the mode switch.
- 4 Select the "OK", and then press the **MODE** switch.

## Display name

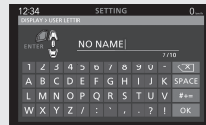

## Instruments *(Continued)*

### MECHANIC

Displays the current information of the vehicle.

Displays the following information:

- Tachometer
- Gear position
- Throttle grip position
- Coolant temperature
- Battery voltage

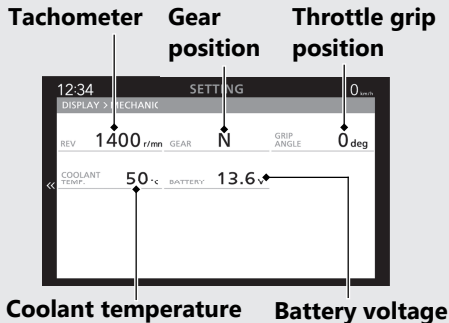





## BRIGHTNESS

You can adjust the backlight brightness to one of the eight levels or select the auto adjustment.

**Automatic brightness control:**  P.229

The display can become dark when the display is very hot. If it does not restore the original brightness, contact your dealer.

- 1 Select the backlight brightness using the  sel up or  sel down switch.
- 2 Return to the ordinary display or upper hierarchy to complete the setting.
  - ▶ You can also complete the setting by pressing the  of the   sel left/right switch.

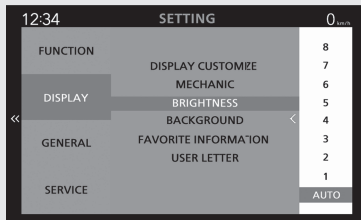

## Instruments *(Continued)*

### BACKGROUND

You can change the setting of the background to one of the two categories or select the auto adjustment.

#### Automatic Background Control:

➔ P.229

- 1 Select the "AUTO", "BLACK" or "WHITE" using the ▲ sel up or ▼ sel down switch.
- 2 Return to the ordinary display or upper hierarchy to complete the setting.
  - ▶ You can also complete the setting by pressing the ◀ of the ◀▶ sel left/right switch.

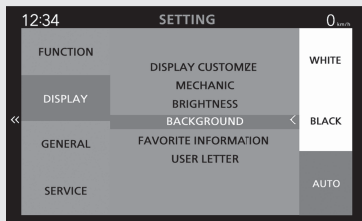

## FAVORITE INFORMATION

You can change the types of information displayed in "INFO1", "INFO2", and "INFO3" of the INFO area.

If the number of items to be displayed on the INFO area is set to "NONE", "FAVORITE INFORMATION" cannot be usable. **➡P.63**

**➡P.75**

- 1 Select the "INFO1", "INFO2" or "INFO3" using the ▲ sel up or ▼ sel down switch.
- 2 Select to the desired setting according to the switch operation guide.
  - ▶ If you select the item that is already selected in another area, the previously selected item will automatically turn the "BRANK".
- 3 Return to the ordinary display or upper hierarchy to complete the setting.

The number of items displayed on the INFO area changes according to the "DISPLAY CUSTOMIZE" setting. **➡P.63** **➡P.75**

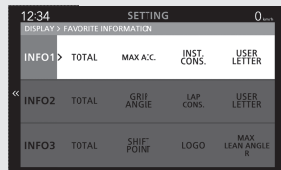



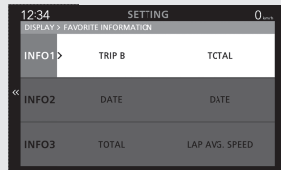

Or



## Instruments *(Continued)*

### USER LETTER

You can edit the USER LETTER with up to 10 characters.

- 1 Select the "USER LETTER".
- 2 Edit the USER LETTER.
  - ▶ To select the character using the  sel up switch,  sel down switch, and  sel left/right switch.
  - ▶ To set the character using the mode switch.
- 3 Select the "OK", and then press the  switch.



## LAP DATA

You can check and clear the recorded lap data.

If there is no lap data, "LAP DATA" cannot be selected.

To display the other lap information, press the ▲ sel up switch or ▼ sel down switch.

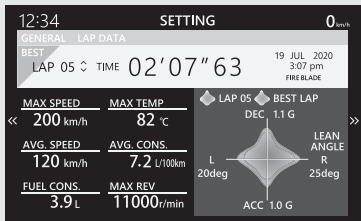

To use the lap timer: ➡ P.57

## To clear the recorded lap data:

- 1 Push and hold the ► of the ◀ ► sel left/right switch.
- 2 Reset the lap data according to the switch operation guide.



## Instruments *(Continued)*

### DATE & TIME

- 1 Select the "24h or 12h", "YEAR", "MONTH / DAY", "HOUR / MINUTE" or "am / pm" using the ▲ sel up or ▼ sel down switch.
- 2 Select to the desired setting according to the switch operation guide.
  - ▶ When "24 / 12" is set to 24-hour indication, "am / pm" cannot be usable.
- 3 Return to the ordinary display or upper hierarchy to complete the setting.

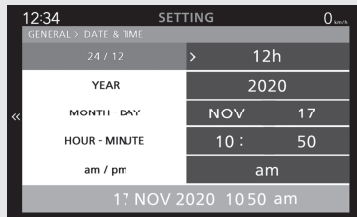



## UNIT

ED, II ED, II GS type

You can change the speed and mileage, and fuel mileage meter units.

- 1 Select the "SPEED" or "FUEL CONS." using the ▲ sel up or ▼ sel down switch.
  - ▶ "TEMP" is displayed but not usable.
- 2 Select to the desired setting according to the switch operation guide.
- 3 Return to the ordinary display or upper hierarchy to complete the setting.

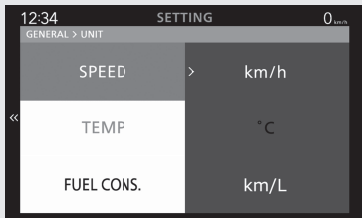

If you want to select "L/100km" or "km/L" for fuel consumption, "km/h" must be selected in the "SPEED" menu in advance.

When "mph" for speed is selected, "mile/gal" or "mile/L" can be selected.

## Instruments *(Continued)*

### LANGUAGE

Changes the system language.

- 1 Select the "English" or "Turkish" using the ▲ sel up or ▼ sel down switch.
- 2 Return to the ordinary display or upper hierarchy to complete the setting.
  - ▶ You can also complete the setting by pressing the ◀ of the ◀ ▶ sel left/right switch.

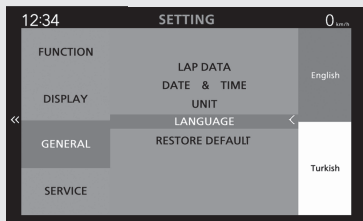

### RESTORE DEFAULT

The set values can be returned to the default settings.

Reset the settings according to the switch operation guide.



The following items are restored to their default values:

- CBR1000SP  
QUICK SHIFTER
- CBR1000SP  
SUSPENSION A/M MODE
- LAP DATA
- DISPLAY CUSTOMIZE
- REV INDICATOR
- BRIGHTNESS
- BACKGROUND
- USER LETTER
- FAVORITE INFORMATION
- DATE & TIME
- UNIT
- START MODE REV
- RIDING MODE
- STEERING DAMPER
- FAVORITE selection
- INFO selection page
- ABS MODE
- LANGUAGE

## Instruments *(Continued)*

### MAINTENANCE

You can check the next inspection time and change the setting of next inspection.

#### Next periodic inspection

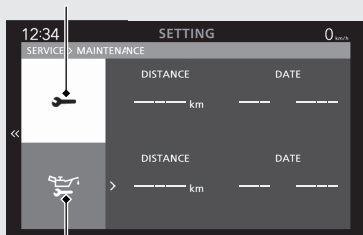

#### Next engine oil change

To return to the upper level hierarchy, press and hold the **MODE** switch.

Display range:

DISTANCE:

Next periodic inspection:

-----, 12,875 to -99,999 km

-----, (8,000 to -99,999 mile)

Next engine oil change:

-----, 12,875 to -99,999 km

-----, (8,000 to -99,999 mile)

▶ Pass 0 km (mile): "-" mark is displayed.

DATE:

Month: ---, JAN to DEC

Year: ----, 2019 to 2119

When reaching any of the following, the pop-up information is appears in the ordinary display. ➔P.52

- "500 km" or "300 mile" from the next periodic inspection.
- "100 km" or "60 mile" from the next engine oil change.
- One month before the set month.

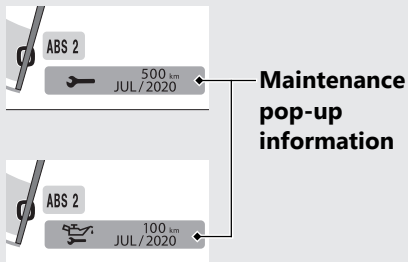

If distance is not set, "-----" is displayed.

## Instruments *(Continued)*

### Next inspection setting

- 1 Select "🔑" (periodic inspection) or "🛠️" (engine oil change) using the ▲ sel up or ▼ sel down switch.

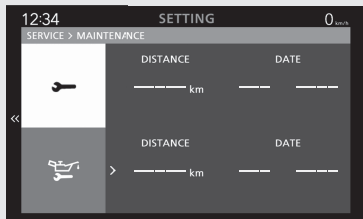

- 2 Select to the desired setting according to the switch operation guide.
  - ▶ If you press and hold the ▲ sel up or ▼ sel down switch while setting the "DISTANCE", it will move every 1000.
  - ▶ Available setting range of the DISTANCE:
    - Periodic inspection
      - Except II GS type**  
-----, 100 to 12,000 km (100 to 8,000 mile)
      - II GS type**  
-----, 100 to 6,000 km (100 to 4,000 mile)
    - Engine oil change  
-----, 100 to 12,000 km (100 to 8,000 mile)
- 3 Return to the ordinary display or upper hierarchy to complete the setting.

## EQUIPMENT

"EQUIPMENT" is displayed but not selectable.

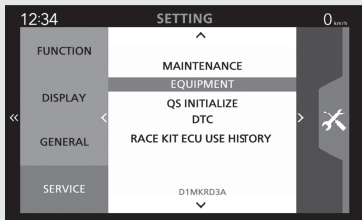

## QS INITIALIZE

"QS INITIALIZE" is displayed but not selectable.

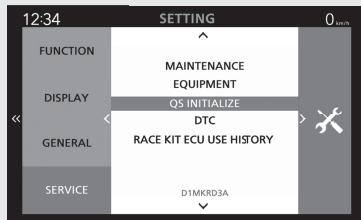

## Instruments *(Continued)*

### DTC

Displays a current problem with the vehicle. If your vehicle has problem, DTC index is displayed.

Reduce speed and have your vehicle inspected by your dealer as soon as possible.

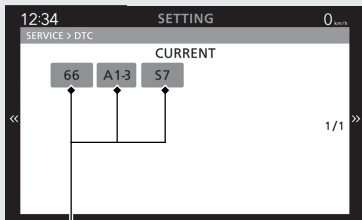

**DTC indexes**

### RACE KIT ECU USE HISTORY

"RACE KIT ECU USE HISTORY" is displayed but not usable.

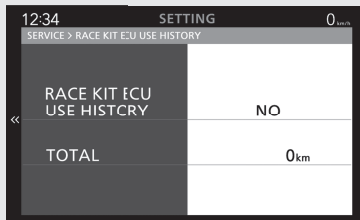



# Indicators

If one of these indicators does not come on when it should, have your dealer check for problems.

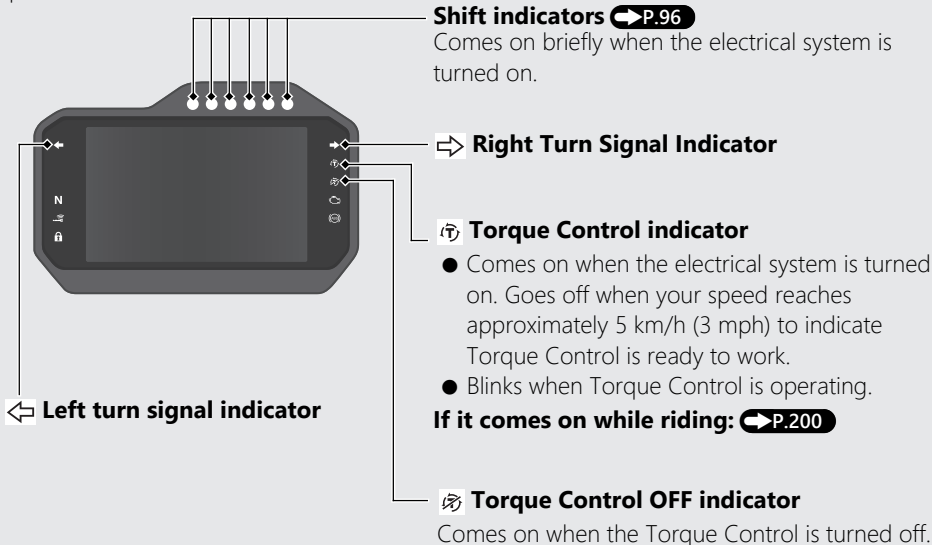

## Indicators *(Continued)*

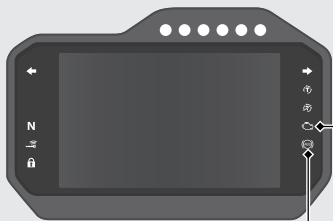

### **PGM-FI (Programmed Fuel Injection) malfunction indicator lamp (MIL)**

Comes on briefly when the electrical system is turned on.

**If it comes on while engine is running:**

 **P.198**

### **ABS (Anti-lock Brake System) indicator**

Comes on when the electrical system is turned on. Goes off when your speed reaches approximately 10 km/h (6 mph).

**If it comes on while riding:**  **P.199**

### **Neutral indicator**

Comes on when the transmission is in Neutral.

### **Honda SMART Key indicator**

Comes on briefly when the electrical system is turned on.

**When the Honda SMART Key Indicator Flashes:**

 **P.201**

### **Steering lock indicator**

Comes on briefly while the steering lock is activating.

**Steering lock:**  **P.102**



## Indicators *(Continued)*

### Shift Indicators

The shift indicators light or blink by the engine revolutions.

The timing and brightness of the indicators light/blink depend on the "REV INDICATOR" setting.

**Setting of the Shift Indicators** **P.63** **P.73**

The indicator colours are as follows.

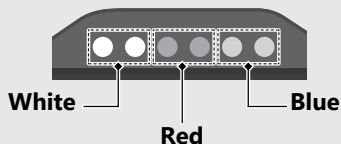

### Definition:

	Engine revolutions	<	$A - (B \times 6)$		
$A - (B \times 6)$	$\leq$	Engine revolutions	<	$A - (B \times 5)$	
$A - (B \times 5)$	$\leq$	Engine revolutions	<	$A - (B \times 4)$	
$A - (B \times 4)$	$\leq$	Engine revolutions	<	$A - (B \times 3)$	
$A - (B \times 3)$	$\leq$	Engine revolutions	<	$A - (B \times 2)$	
$A - (B \times 2)$	$\leq$	Engine revolutions	<	$A - (B \times 1)$	
$A - (B \times 1)$	$\leq$	Engine revolutions	<	A	
A	$\leq$	Engine revolutions			





A: SHIFT POINT value

B: INTERVAL value



# Switches

## Headlight dimmer switch/PASSING/LAP switch

-  : High beam
-  : Low beam
-  /LAP: Flashes the high beam headlight.  
Also use lap timer.  **P.57**

## Horn button

## Hazard switch

Switchable when the electrical system is on. Can be turned to off regardless of whether the electrical system is on or off.

- ▶ The signals continue flashing with turn the electrical system is off after the hazard switch is on.

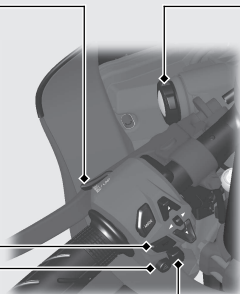

## Turn signal switch

The turn signal will automatically stop when you complete the turn. (You can manually cancel the lights by pressing the switch in.) When used for a lane change, the turn signal will automatically stop in about 7 seconds or after riding 150 m (164 yards). In some cases, the timing at which the turn signal stops could be less or more. Always use the recommended tyres to ensure correct automatic cancellation operation.



## Ignition Switch

Switches the electrical system on/off, locks the steering.

- ▶ Make sure that the Honda SMART Key is activated  P.105 and enter the operating range.  P.106

Ignition switch knob ○/🔒 (Off/Lock)



Ignition | (On) switch

 (Lock) Locks steering.  P.102





○ (Off) Turns engine off.



| (On) Turns electrical system on for starting/riding.

 → Push the ignition | (On) switch.

 → Turn the ignition switch knob ○/🔒 (Off/Lock) counterclockwise.

 → Turn and hold the ignition switch knob ○/🔒 (Off/Lock) counterclockwise.

## Switches *(Continued)*

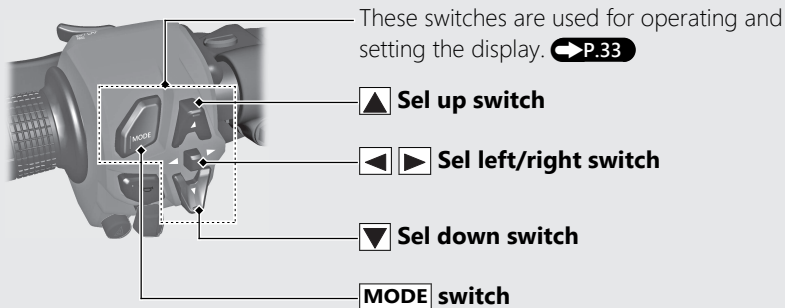

### **Engine stop switch/ ⚡ Start button**

Should normally remain in the Ⓞ (Run) position.

- ▶ In an emergency, switch to the ⚡ (Stop) position to stop the engine.



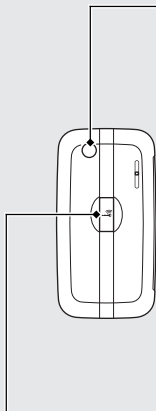

### **ON/OFF button**

This button is used to activate or deactivate the Honda SMART Key system and also to confirm the activation status.  **P.105**

### **Release button**

This button is used to release the mechanical key.

The mechanical key is used when refuelling or removing the rear seat.

Avoid contact with the key whenever it extends or retracts.

### **To release the mechanical key**

Press the release button to release the mechanical key.

▶ Make sure to fully extend the key.

### **To retract the mechanical key**

Push the key into the key case while pressing the release button.

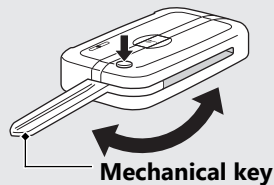

## Switches *(Continued)*

### Steering Lock

Lock the steering when parking to help prevent theft.

A U-shaped wheel lock or similar device is also recommended.

- ▶ When using a U-shaped wheel lock or similar device, be careful not to damage the wheels.

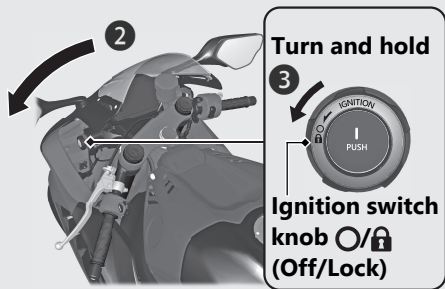

### Locking

- 1 Turn the ignition switch knob ○/🔒 (Off/Lock) counterclockwise to turn off the electrical system.
- 2 Turn the handlebars all the way to the left.





3 Turn and hold the ignition switch knob  (Off/Lock) counterclockwise.

- ▶ The steering lock indicator comes on briefly and the steering is automatically locked.
- ▶ If the steering lock indicator blinks, the steering has not been locked completely because the steering was not positioned all the way to the left.  
If this occurs, reposition the handlebars all the way to the left, then turn and hold the ignition switch counterclockwise (The steering can also be locked by positioning it all the way to the left within seconds after the steering lock indicator start blinking).  
Make sure the steering is locked.

**Steering lock indicator**



## Unlocking

- 1 Make sure that the Honda SMART Key is activated  and enter the operating range. 
- 2 Push the ignition  (On) switch.
  - ▶ The steering is unlocked automatically.
  - ▶ If the steering lock indicator blinks, the steering is not unlocked because of excessive force on the steering.  
If this occurs, reposition the handlebars all the way to the left, then push the ignition  (On) switch. (The steering can also be unlocked by positioning it all the way to the left within seconds after the steering lock indicator start blinking).

# Honda SMART Key System

The Honda SMART Key system allows you to operate the main switch without inserting a key into a keyhole.

The system runs a two-way authentication between the vehicle and the Honda SMART Key to verify if it is the registered Honda SMART Key.

The Honda SMART Key system uses low-intensity radio waves. It may affect medical equipment such as a cardiac pacemakers.

## Switching the Honda SMART Key System

### To switch the Honda SMART Key system to activation or deactivation

Press the ON/OFF button until the LED colour of the Honda SMART Key changes.

### To check the Honda SMART Key system status

Lightly press the ON/OFF button. The LED of the Honda SMART Key will show the status.

When the LED of the Honda SMART Key is:

Green: Honda SMART Key system authentication can be performed.

Red: Honda SMART Key system authentication can not be performed.

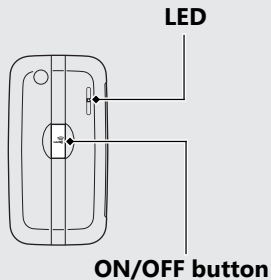

## Honda SMART Key System *(Continued)*

### Operating Range

The Honda SMART Key system uses low-intensity radio waves. Therefore the operating range may become wider or narrower, or the Honda SMART Key system may not work properly in the following environments.

- When the Honda SMART Key battery is depleted.
- When there are facilities nearby that generate strong radio waves or noise such as TV towers, power stations, radio stations, or airports.
- When you carry the Honda SMART Key with a laptop or wireless communication device such as a radio or mobile phone.
- When the Honda SMART Key comes into contact with or is covered by metal objects.

The system can be operated when the Honda SMART Key is within the shaded area shown in the illustration.

- ▶ Placing the Honda SMART Key on the fuel tank may cause communication failure.

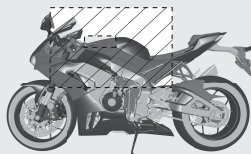
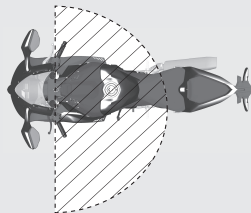

Anyone can operate the ignition switch and start the engine if your Honda SMART Key is within operating range of your vehicle, even if you are on the other side of a wall or window. If you are away from your vehicle but your Honda SMART Key will still be within the system's operating range, deactivate the Honda SMART Key system.

### Activate or deactivate the Honda SMART Key system P.105

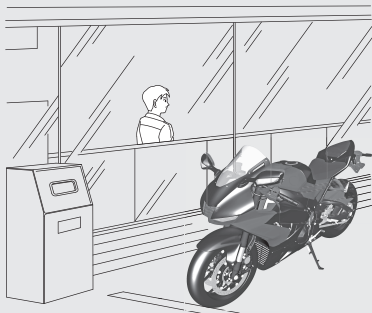

Anyone in possession of the Honda SMART Key can perform the following operations if the Honda SMART Key is within operating range:

- Starting the engine
- Unlocking the steering lock

You should always keep the Honda SMART Key on your person after you get on and off the vehicle or while riding.

Do not place the Honda SMART Key in the under the rear seat.

## Honda SMART Key System *(Continued)*

If the electrical system is on, the vehicle can be operated even by a person who does not have a verified Honda SMART Key.

Whenever you leave your vehicle, turn off the electrical system and lock the steering.

➡ P.102

### Operating the Ignition Switch

#### To Activate the Electrical System

- 1 Make sure that the Honda SMART Key is activated and enter the operating range for the vehicle. ➡ P.105
- 2 Push the ignition  (On) switch. ➡ P.99
  - ▶ The electrical system activates and the engine can be started.

#### Honda SMART Key

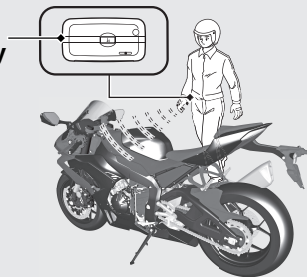

#### To turn Off the Electrical System

- 1 Turn the ignition switch knob  (Off/Lock) counterclockwise
- 2 Leave the operating range with the Honda SMART Key ➡ P.106 or switch the Honda SMART Key system to deactivation. ➡ P.105

**When the Honda SMART Key system does not work properly** ➡ P.202



# Riding mode

You can change the riding mode.  
The riding mode consists of the following parameters.

P: Engine output level

T: Torque control level

W: Wheelie control level

EB: Engine brake level

**CBR1000SP**

S: Suspension mode

When “-” is displayed, go to your dealer for service.

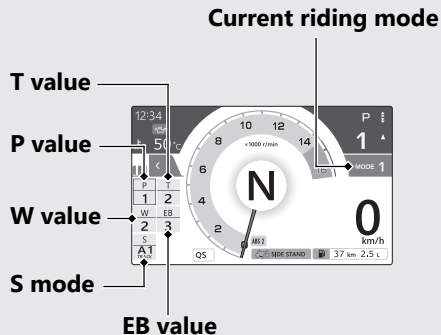

## Riding mode *(Continued)*

Riding mode has three modes.

Available riding mode: MODE 1, MODE 2 or MODE 3.

Each value can be changed.

**CBR1000SP**

Setting of S mode can be changed.

### Initial setting

Riding modes	P value	T value	W value	EB value	S mode
					<b>CBR1000SP</b>
MODE 1	1	2	2	3	A1 (TRACK)
MODE 2	2	5	2	3	A2 (SPORT)
MODE 3	5	8	3	1	A3 (RAIN)

### **P value (Engine output level)**

P value has five setting levels.

Available setting range: 1 to 5

- ▶ Level 1 has the most power.
- ▶ Level 5 has the least power.

### **T value (Torque control level)**

T value has ten setting levels.

Available setting range: 0 to 9

- ▶ Level 1 is the minimum Torque Control level.
- ▶ Level 9 is the maximum Torque Control level.
- ▶ Level 0 deactivates the Torque Control.
- ▶ When the T value is set to 0, the W value automatically changes 0.
- ▶ If the electrical system is turned from off to on while the T value is set to 0, the T value is automatically set to 1. W value returns to the level before T value was set to 0.

### **W value (Wheelie control level)**

W value has four setting levels.

Available setting range: 1 to 3

- ▶ Level 1 is the minimum Wheelie Control level.
- ▶ Level 3 is the maximum Wheelie Control level.
- ▶ Level 0 deactivates the Wheelie Control.

### **EB value (Engine brake level)**

EB value has three setting levels.

Available setting range: 1 to 3

- ▶ Level 1 has the strongest engine braking effect.
- ▶ Level 3 has the weakest engine braking effect.

### **S mode (Suspension mode)**

**CBR1000SP**

S mode has six modes.

Available modes: A1, A2, A3, M1, M2 and M3

### **Adjusting the ÖHLINS Smart EC system**

➔ P.185

## Riding mode *(Continued)*

### Selecting the riding mode

The riding mode changes each time the **MODE** switch is pressed.

- ▶ When the riding mode is changed the P, T, W, and EB values are appeared briefly in the INFO area.

**CBR1000SP**

The S value also appears.

#### **MODE** switch

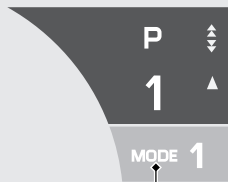
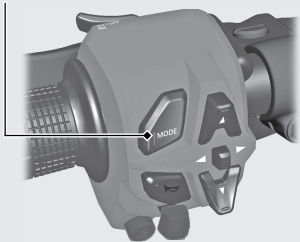

**Current riding mode**

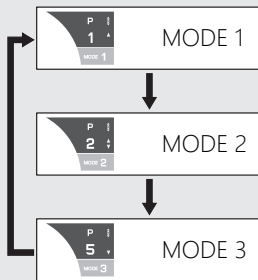

➔ Press the **MODE** switch

## Setting the riding mode

### CBR1000ST

You can change the P, T, W and EB values.

### CBR1000SP

You can change the P, T, W, EB values and S mode.

You can change the riding mode setting from the setting mode of display. P.63

P.67

The value displayed in FAVORITE can be changed without shifting to the setting mode of display.

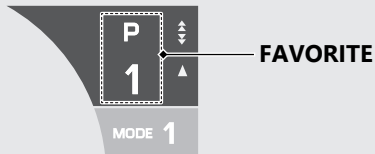

1 Select the riding mode you want to set.

P.112

2 **To change the type of parameter displayed in FAVORITE**

Press and hold the sel up switch or sel down switch to select the parameter.

**To change the value of parameter displayed in FAVORITE**

Press the sel up or sel down switch to select the value.

▶ The T value cannot be set to 0 in FAVORITE.

To set the T value to 0, set in the setting mode of the display. P.63

P.67

## Riding mode (Continued)

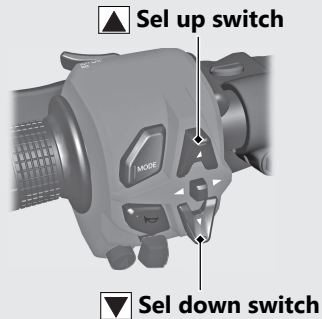
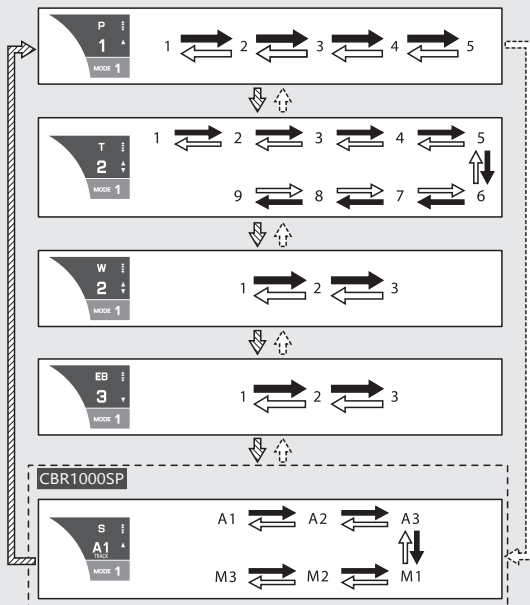

- Press and hold the ▲ sel up switch
- Press and hold the ▼ sel down switch
- Press the ▲ sel up switch
- Press the ▼ sel down switch

# Starting the Engine

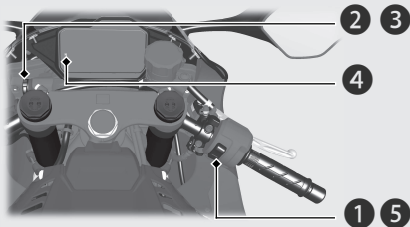

Start your engine using the following procedure, regardless of whether the engine is cold or warm.

This vehicle is equipped with a Honda SMART Key system. Always keep Honda SMART Key on you when you ride the vehicle. ➔P.104



## NOTICE

- If the engine does not start within 5 seconds, turn the electrical system off and wait 10 seconds before trying to start the engine again to recover battery voltage.
- Extended fast idling and reving the engine can damage the engine, and the exhaust system.
- Snapping the throttle or fast idling for more than about 5 minutes may cause exhaust pipe discolouration.
- The engine will not start if the throttle is fully open.

- 1 Make sure the engine stop switch is in the  (Run) position.
- 2 Unlock the steering. ➔P.103
- 3 Activate the electrical system. ➔P.105
- 4 Shift the transmission to Neutral (  indicator comes on). Alternatively, pull in the clutch lever to start your vehicle with the transmission in gear so long as the side stand is raised.
- 5 Press the start button with the throttle completely closed.

## Starting the Engine *(Continued)*

### If the engine does not start:

- ① Open the throttle fully and press the start button for 5 seconds.
- ② Repeat the normal starting procedure.
- ③ If the engine starts, open the throttle slightly if idling is unstable.
- ④ If the engine does not start, wait 10 seconds before trying steps ① & ② again.

### If Engine Will Not Start P.196



# Shifting Gears

Your vehicle transmission has 6 forward gears in a one-down, five-up shift pattern.

If you put the vehicle in gear with the side stand down, the engine will shut off.

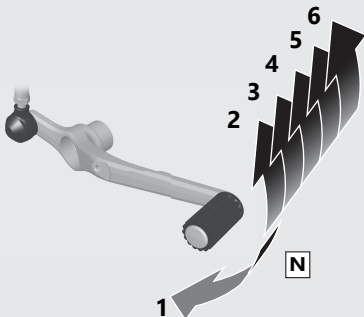

## Shifting Gears *(Continued)*

### Quick Shifter

#### CBR1000SP

This system enables very quick up and down shifting without clutch and throttle operations.

- ▶ This system does not function when upshifting with the throttle closed.
  - ▶ This system functions when the engine speed is more than 1,500 r/min (rpm) on upshifting or more than the idle speed on downshifting.
  - ▶ This system does not function when the clutch lever is being operated.
- If "-" is displayed on the gear position indicator, the Quick Shifter system does not operate.
  - If the Quick Shifter does not operate normally, the clutch can be used to complete the shift operation.

- The Quick Shifter can be individually turned ON (active) and OFF (deactivate), also the shift pedal load level for activating the Quick Shifter can be adjusted during up and down shifting.
- If the PGM-FI malfunction indicator lamp comes on or the gear position indicator flashes "-" in the current gear position, the Quick Shifter system may not operate. If either of the above occurs, contact your dealer as soon as possible.

### **To Change the Setting of Quick Shifter**

➡ P.63

➡ P.70

# Start Mode

Your vehicle controls the engine torque to support optimal acceleration from standstill.

## **⚠ WARNING**

Using the start mode on public roads can lead to a crash in which you, other pedestrians and drivers could be seriously hurt or killed.

Only use the start mode on a closed course.

The system puts a tremendous load on the clutch. Frequent use of this system may lead to reduced engine life.

Have your dealer check the clutch for wear or replace if necessary.

## To set the start mode

- 1 Start the engine. ➡ P.115
- 2 Stop the vehicle completely.
- 3 Set to the SPORT mode. ➡ P.63 ➡ P.75
- 4 Press and hold the ▲ sel up or ▼ sel down switch and PASSING/LAP switch until the "START MODE" message appears in the display.

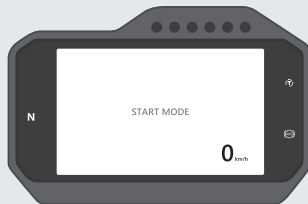

## Start Mode *(Continued)*

In the following cases, pop-up information of "START MODE" with gray background appears, system is not allowed.

- The vehicle is not at standstill.
- Torque Control is off.
- The gear position is other than neutral or 1st gear.
- The side stand is down.
- The throttle is not closed completely.
- The coolant temperature is low.
- The "START MODE REV" setting is "OFF".

➡ P.63   ➡ P.74

- 5 Press and hold the ▲ sel up or ▼ sel down switch and PASSING/LAP switch until the "START MODE" pop-up information with orange background appears in the display. The system is allowed.
- 6 Shift the transmission to 1st gear.

- 7 Start the vehicle with the throttle fully open.
  - ▶ The engine revolution is limited by the set value of "START MODE REV", the pop-up information changes from orange background to green background, all shift indicators start flashing. To set the engine revolutions.
    - ➡ P.63   ➡ P.73
  - ▶ Engage the clutch gradually.
  - ▶ After engaging the clutch, start mode controls the optimum torque.

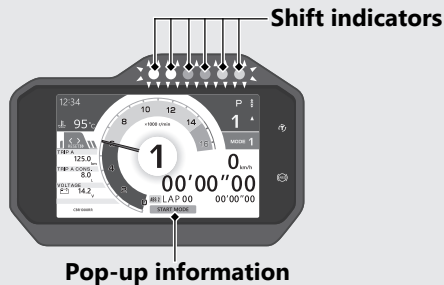

After the vehicle has started, the system is deactivated under one of the following conditions.

- Reach the 3rd gear.
- Reach the engine revolution of the shift indicator limit value in 1st gear. **→P.63**
- **→P.73**
- Reach the lean angle is more than 20 degrees.
- Close the throttle.

**NOTICE**

To prevent clutch damage, do not use the start mode repeatedly. You must wait 3 minutes after initial use.

# Emergency Stop Signal

Emergency stop signal activates when the system detects hard braking about 50 km/h (31 mph) or above to alert drivers behind you about sudden braking by rapidly flashing both turn signal lights. This may help to alert drivers behind you to take appropriate means to avoid a possible collision with your vehicle.

The emergency stop signal stops operating when:

- You release the brakes.
- The ABS is deactivated.
- Your vehicle's decelerating speed becomes moderate.
- You press the hazard switch.

## When the system activates:



**1 Hard braking**

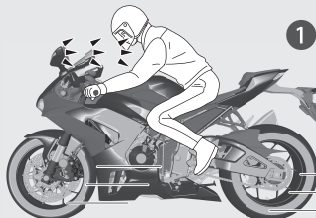

**1 Brakelight come on**

**2 Both turn signals flash**

**2 Both turn signal indicators blink**

- ▶ The emergency stop signal is not a system that can prevent a possible rear-end collision caused by your hard braking. It is always recommended to avoid hard braking unless it is absolutely necessary.
- ▶ The emergency stop signal does not activate with the hazard switch pressed in.
- ▶ If the ABS stops working for a certain period during braking, the emergency stop signal may not activate at all.

# Refuelling

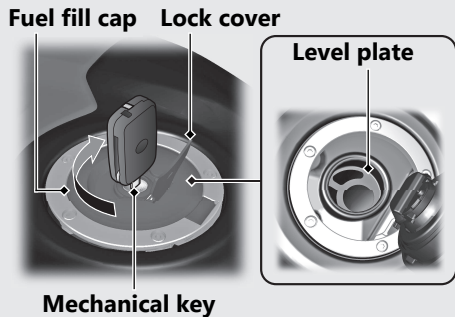

Do not fill with fuel above the level plate.

**Fuel type:** Unleaded petrol only

**Fuel octane number:** Your vehicle is designed to use Research Octane Number (RON) 95 or higher.

**Tank capacity:** 16.1 L (4.25 US gal, 3.54 Imp gal)

**Refuelling and Fuel Guidelines** ➔ P.18

## Opening the Fuel Fill Cap

Open the lock cover, insert the mechanical key, and turn it clockwise to open the fuel fill cap.

## Closing the Fuel Fill Cap

- ➊ After refuelling, push the fuel fill cap closed until it locks.
- ➋ Remove the mechanical key and close the lock cover.
  - ▶ The mechanical key cannot be removed if the fuel fill cap is not locked.

## **⚠ WARNING**

Petrol is highly flammable and explosive. You can be burned or seriously injured when handling fuel.

- Stop the engine, and keep heat, sparks, and flame away.
- Handle fuel only outdoors.
- Wipe up spills immediately.



# Storage Equipment

## Helmet Holder

The helmet holders are located underside of the rear seat.

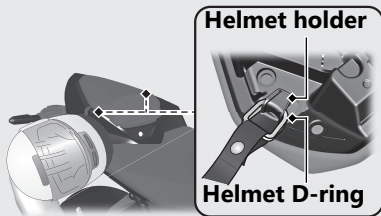

► Use the helmet holder only when parked.

**Removing the Rear Seat** ➔ P.154

## **⚠ WARNING**

Riding with a helmet attached to the holder can interfere with your ability to safely operate the vehicle and could lead to a crash in which you can be seriously hurt or killed.

Use the helmet holder only while parked. Do not ride with a helmet secured by the holder.

## Storage Equipment *(Continued)*

### Tool kit/Owner's manual

The tool kit is located under the rear seat.

The owner's manual is stored in the tool bag.

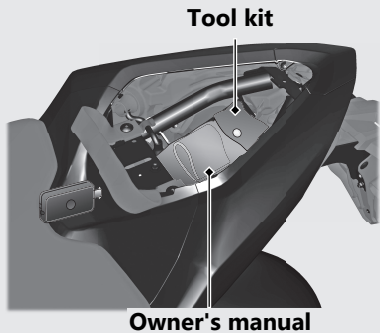

Removing the Rear Seat [➔ P.154](#)

# Maintenance

Please read "Importance of Maintenance" and "Maintenance Fundamentals" carefully before attempting any maintenance. Refer to "Specifications" for service data.

<b>Importance of Maintenance</b> .....	P. 128	<b>Side Stand</b> .....	P. 167
<b>Maintenance Schedule</b> .....	P. 129	<b>Drive Chain</b> .....	P. 168
<b>Maintenance Fundamentals</b> .....	P. 134	<b>Clutch</b> .....	P. 172
<b>Tool</b> .....	P. 149	<b>Throttle</b> .....	P. 175
<b>Removing &amp; Installing Body</b>		<b>Other Adjustments</b> .....	P. 176
<b>Components</b> .....	P. 150	Adjusting the Headlight Aim.....	P. 176
Battery.....	P. 150	Adjusting the Brake Lever.....	P. 177
Clip.....	P. 152	Adjusting the Front Suspension .....	P. 179
Front Seat.....	P. 153	Adjusting the Rear Suspension.....	P. 182
Rear Seat.....	P. 154	Adjusting the ÖHLINS Smart EC System....	P. 185
Under Cowl.....	P. 155	<b>Other Replacement</b> .....	P. 193
<b>Engine Oil</b> .....	P. 157	Replacing the Honda SMART Key Battery ..	P. 193
<b>Coolant</b> .....	P. 161		
<b>Brakes</b> .....	P. 164		

# Importance of Maintenance

## Importance of Maintenance

Keeping your vehicle well-maintained is absolutely essential to your safety and to protect your investment, obtain maximum performance, avoid breakdowns, and reduce air pollution. Maintenance is the owner's responsibility. Be sure to inspect your vehicle before each ride, and perform the periodic checks specified in the Maintenance Schedule.

➔ P. 129

### **⚠ WARNING**

Improperly maintaining your vehicle or failing to correct a problem before you ride can cause a crash in which you can be seriously hurt or killed.

Always follow the inspection and maintenance recommendations and schedules in this owner's manual.

## Maintenance Safety

Always read the maintenance instructions before you begin each task, and make sure that you have the tools, parts, and skills required. We cannot warn you of every conceivable hazard that can arise in performing maintenance. Only you can decide whether or not you should perform a given task.

Follow these guidelines when performing maintenance.

- Stop the engine and keep the electrical system off.
- Place your vehicle on a firm, level surface using the side stand or a maintenance stand to provide support.
- Allow the engine, muffler, brakes, and other high-temperature parts to cool before servicing as you can get burned.
- Run the engine only when instructed, and do so in a well-ventilated area.

## Maintenance Schedule

The maintenance schedule specifies the maintenance requirements necessary to ensure safe, dependable performance, and proper emission control.

Maintenance work should be performed in accordance with Honda's standards and specifications by properly trained and equipped technicians. Your dealer meets all of these requirements. Keep an accurate record of maintenance to help ensure that your vehicle is properly maintained.









Make sure that whomever performs the maintenance completes this record.

All scheduled maintenance is considered a normal owner operating cost and will be charged to you by your dealer. Retain all receipts. If you sell the vehicle, these receipts should be transferred with the vehicle to the new owner.



Honda recommends that your dealer should road test your vehicle after each periodic maintenance is carried out.

## Maintenance Schedule

Except II GS type

Items		Pre-ride Check P. 134	Frequency*1					Annual Check	Regular Replace	Refer to page	
			× 1,000 km	1	12	24	36				48
			× 1,000 mi	0.6	8	16	24				32
Fuel Line				<b>I</b>	<b>I</b>	<b>I</b>	<b>I</b>	<b>I</b>		–	
Fuel Level		<b>I</b>								124	
Throttle Operation		<b>I</b>		<b>I</b>	<b>I</b>	<b>I</b>	<b>I</b>	<b>I</b>		175	
Air Cleaner *2					<b>I</b>		<b>I</b>			–	
Spark Plug					<b>I</b>		<b>R</b>			–	
Valve Clearance					<b>I</b>		<b>I</b>			–	
Engine Oil		<b>I</b>	<b>R</b>	<b>R</b>	<b>R</b>	<b>R</b>	<b>R</b>	<b>R</b>		159	
Engine Oil Filter			<b>R</b>		<b>R</b>		<b>R</b>			159	
Engine Idle Speed				<b>I</b>	<b>I</b>	<b>I</b>	<b>I</b>	<b>I</b>		–	
Radiator Coolant *3		<b>I</b>		<b>I</b>	<b>I</b>	<b>I</b>	<b>I</b>	<b>I</b>	3 Years	161	
Cooling System				<b>I</b>	<b>I</b>	<b>I</b>	<b>I</b>	<b>I</b>		–	
Secondary Air Supply System					<b>I</b>		<b>I</b>			–	
Evaporative Emission Control System (ED, II ED type)					<b>I</b>		<b>I</b>			–	

### Maintenance Level

-  : Intermediate. We recommend service by your dealer, unless you have the necessary tools and are mechanically skilled. Procedures are provided in an official Honda Shop Manual.
-  : Technical. In the interest of safety, have your vehicle serviced by your dealer.

### Maintenance Legend

- I** : Inspect (clean, adjust, lubricate, or replace, if necessary)
- R** : Replace
- L** : Lubricate

## Maintenance Schedule

Items	Pre-ride Check P. 134	Frequency*1						Annual Check	Regular Replace	Refer to page
		× 1,000 km	1	12	24	36	48			
		× 1,000 mi	0.6	8	16	24	32			
Exhaust Gas Control Actuator Cable	✕				I		I			-
Drive Chain	I	Every 1,000 km (600 mi): I L								168
Drive Chain Slider				I	I	I	I			171
Brake Fluid *3	I			I	I	I	I	I	2 Years	164
Brake Pads Wear	I			I	I	I	I	I		165
Brake System				I	I	I	I	I		134
Brakelight Switch				I	I	I	I	I		166
Headlight Aim				I	I	I	I	I		176
Lights/Horn	I									-
Engine Stop Switch	I									-
Clutch System	I			I	I	I	I	I		172
Side Stand	I			I	I	I	I	I		167
Suspension	🔧			I	I	I	I	I		179
Front Fork Oil (CBR1000SP)	✕	Every 15,000 km (10,000 mi): R							2 Years	-
Nuts, Bolts, Fasteners	🔧			I	I	I	I	I		-
Wheels/Tyres	✕	I		I	I	I	I	I		145
Steering Head Bearings	✕			I	I	I	I	I		-

### Notes:









\*1: At higher odometer readings, repeat at the frequency interval established here.

\*2: Service more frequently when riding in unusually wet or dusty areas.



\*3: Replacement requires mechanical skill.

## Maintenance Schedule

### II GS type

Items	Pre-ride Check P. 134	Frequency*1								Annual Check	Regular Replace	Refer to page	
		× 1,000 km	1	6	12	18	24	30	36				
		× 1,000 mi	0.6	4	8	12	16	20	24				
Fuel Line					I		I		I	I		-	
Fuel Level		I										124	
Throttle Operation		I			I		I		I	I		175	
Air Cleaner *2						R			R			148	
Spark Plug			Every 24,000 km (16,000 mi): I Every 48,000 km (32,000 mi): R										-
Valve Clearance							I					-	
Engine Oil		I	R		R		R		R	R		159	
Engine Oil Filter			R				R					159	
Engine Idle Speed					I		I		I	I		-	
Radiator Coolant *3		I			I		I		I	I	3 Years	161	
Cooling System					I		I		I	I		-	
Secondary Air Supply System							I					-	

### Maintenance Level

-  : Intermediate. We recommend service by your dealer, unless you have the necessary tools and are mechanically skilled. Procedures are provided in an official Honda Shop Manual.
-  : Technical. In the interest of safety, have your vehicle serviced by your dealer.

### Maintenance Legend

- I** : Inspect (clean, adjust, lubricate, or replace, if necessary)
- R** : Replace
- L** : Lubricate



Items	Pre-ride Check P. 134	Frequency*1									Annual Check	Regular Replace	Refer to page
		× 1,000 km	1	6	12	18	24	30	36				
		× 1,000 mi	0.6	4	8	12	16	20	24				
Exhaust Gas Control Actuator Cable									I				
Drive Chain	I	Every 1,000 km (600 mi): I L											168
Drive Chain Slider					I			I			I		171
Brake Fluid *3	I			I	I	I	I	I	I	I	I	2 Years	164
Brake Pads Wear	I			I	I	I	I	I	I	I	I		165
Brake System					I			I			I	I	134
Brakelight Switch					I			I			I	I	166
Headlight Aim					I			I			I	I	176
Lights/Horn	I												-
Engine Stop Switch	I												-
Clutch System	I			I	I	I	I	I	I	I	I		172
Side Stand	I				I			I			I	I	167
Suspension					I			I			I	I	179
Front Fork Oil (CBR1000SP)		Every 15,000 km (10,000 mi): R										2 Years	-
Nuts, Bolts, Fasteners					I			I			I	I	-
Wheels/Tyres		I			I			I			I	I	145
Steering Head Bearings					I			I			I	I	-

**Notes:**

\*1 : At higher odometer readings, repeat at the frequency interval established here.

\*2 : Service more frequently when riding in unusually wet or dusty areas.

\*3 : Replacement requires mechanical skill.

## Pre-ride Inspection

To ensure safety, it is your responsibility to perform a pre-ride inspection and make sure that any problem you find is corrected. A pre-ride inspection is a must, not only for safety, but because having a breakdown, or even a flat tyre, can be a major inconvenience.

Check the following items before you get on your vehicle:

- Fuel level - Fill fuel tank when necessary. ➔ P. 124
- Throttle - Check for smooth opening and full closing in all steering positions. ➔ P. 175
- Engine oil level - Add engine oil if necessary. Check for leaks. ➔ P. 157
- Coolant level - Add coolant if required. Check for leaks. ➔ P. 161
- Drive chain - Check condition and slack, adjust and lubricate if necessary. ➔ P. 168
- Brakes - Check operation;  
Front and Rear: check brake fluid level and pads wear. ➔ P. 164, ➔ P. 165
- Lights and horn - Check that lights, indicators and horn function properly.
- Engine stop switch - Check for proper function. ➔ P. 100
- Clutch - Check operation;  
Adjust freeplay if necessary. ➔ P. 172
- Side stand ignition cut-off system - Check for proper function. ➔ P. 167
- Wheels and tyres - Check condition, air pressure and adjust if necessary. ➔ P. 145

## Replacing Parts

Always use Honda Genuine Parts or their equivalents to ensure reliability and safety.

### Except II GS type

When ordering coloured components, specify the model name, colour, and code mentioned on the colour label.

The colour label is attached on the under the rear seat.

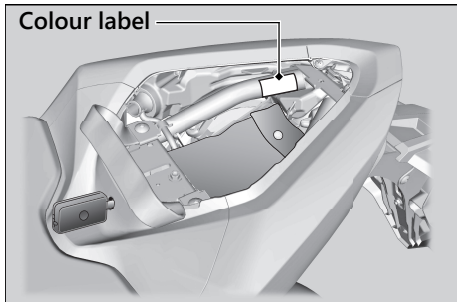

## **⚠ WARNING**

Installing non-Honda parts may make your vehicle unsafe and cause a crash in which you can be seriously hurt or killed.

Always use Honda Genuine Parts or equivalents that have been designed and approved for your vehicle.

### Battery

#### CBR1000SP

Your vehicle has a lithium-ion (li-ion) battery.

➔ P. 138

#### CBR1000ST

Your vehicle has a maintenance-free type battery. You do not have to check the battery electrolyte level or add distilled water. Clean the battery terminals if they become dirty or corroded.

Do not remove the battery cap seals. There is no need to remove the cap when charging.

#### NOTICE

Your battery is a maintenance-free type and can be permanently damaged if the cap strip is removed.



This symbol on the battery means that this product must not be treated as household waste.

#### NOTICE

An improperly disposed of battery can be harmful to the environment and human health. Always confirm local regulations for proper battery disposal instruction.

### What to do in an emergency

If any of the following occur, immediately see your doctor.

- Electrolyte splashes into your eyes:
  - ▶ Wash your eyes repeatedly with cool water for at least 15 minutes. Using water under pressure can damage your eyes.
- Electrolyte splashes onto your skin:
  - ▶ Remove affected clothing and wash your skin thoroughly using water.
- Electrolyte splashes into your mouth:
  - ▶ Rinse mouth thoroughly with water, and do not swallow.

## **⚠ WARNING**

The battery gives off explosive hydrogen gas during normal operation.

A spark or flame can cause the battery to explode with enough force to kill or seriously hurt you.

Wear protective clothing and a face shield, or have a skilled mechanic do the battery servicing.

### Cleaning the Battery Terminals

1. Remove the battery. ➤ P. 150
2. If the terminals are starting to corrode and are coated with a white substance, wash with warm water and wipe clean.

## Maintenance Fundamentals

3. If the terminals are heavily corroded, clean and polish the terminals with a wire brush or sandpaper. Wear safety glasses.

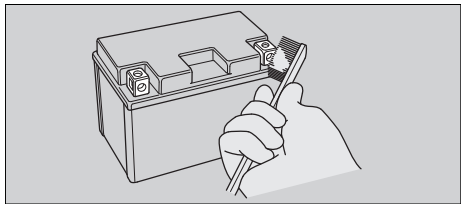

4. After cleaning, reinstall the battery.

The battery has a limited life span. Consult your dealer about when you should replace the battery. Always replace the battery with another maintenance-free battery of the same type.

### NOTICE

Installing non-Honda electrical accessories can overload the electrical system, discharging the battery and possibly damaging the system.

## Lithium-Ion (Li-Ion) Battery

### CBR1000SP

Your vehicle has a lithium-ion (li-ion) battery. Clean the battery terminals if they become dirty or corroded.



This symbol on the battery means that this product must not be treated as household waste.

### NOTICE

An improperly disposed of battery can be harmful to the environment and human health. Always confirm local regulations for proper battery disposal instruction.

**What to do in an emergency**

If any of the following occurs, immediately see your doctor.

- Electrolyte splashes into your eyes:
  - ▶ Wash your eyes repeatedly with cool water for at 15 minutes. Using water under pressure can damage your eyes.
- Electrolyte splashes onto your skin:
  - ▶ Remove affected clothing and wash your skin thoroughly using water.
- Electrolyte splashes into your mouth
  - ▶ Rinse mouth thoroughly with water, and do not swallow.

**⚠ WARNING**

The battery contains flammable organic solvent as electrolyte.

You can be burned or seriously injured if the battery is handled improperly.

- Keep the battery away from heat, sparks, and flame.
- Keep the battery out of the reach of children.
- Do not disassemble or modify the battery or battery terminals.
- Do not short-circuit the battery with metal tools or other metal objects.
- Do not subject the battery to impacts.

### ■ Cleaning the Battery Terminals

1. Remove the battery. ➤ P. 150
2. If the terminals are starting to corrode and are coated with a white substance, wash with warm water and wipe clean.
3. If the terminals are heavily corroded, clean and polish the terminals with a wire brush or sandpaper. Wear safety glasses.

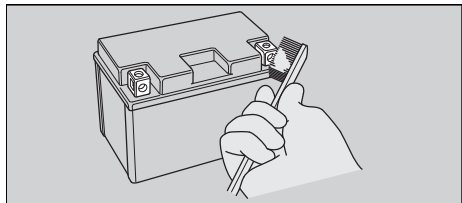

4. After cleaning, reinstall the battery.

The battery has a limited life span. Consult your dealer about when you should replace the battery. Always replace the battery with another lithium-ion (li-ion) battery of the same type.

#### NOTICE

Installing non-Honda electrical accessories can overload the electrical system, discharging the battery and possibly damaging the system.



## Fuses

Fuses protect the electrical circuits on your vehicle. If something electrical on your vehicle stops working, check for and replace any blown fuses. ➤ P. 220

### Inspecting and Replacing Fuses

Turn off the electrical system to remove and inspect fuses. If a fuse is blown, replace with a fuse of the same rating. For fuse ratings, see "Specifications." ➤ P. 242

Blown fuse

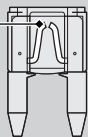

#### NOTICE

Replacing a fuse with one that has a higher rating greatly increases the chance of damage to the electrical system.

If a fuse fails repeatedly, you likely have an electrical fault. Have your vehicle inspected by your dealer.

## Engine Oil

Engine oil consumption varies and oil quality deteriorates according to riding conditions and time elapsed.

Check the engine oil level regularly, and add the recommended engine oil if necessary. Dirty oil or old oil should be changed as soon as possible.

### Selecting the Engine Oil

For recommended engine oil, see "Specifications." ➤ P. 241

If you use non-Honda engine oil, check the label to make sure that the oil satisfies all of the following standards:

- JASO T 903 standard\*<sup>1</sup>: MA
- SAE standard\*<sup>2</sup>: 10W-30
- API classification\*<sup>3</sup>: SG or higher

## Maintenance Fundamentals

- \*1. The JASO T 903 standard is an index for engine oils for 4-stroke motorcycle engines. There are two classes: MA and MB. For example, the following label shows the MA classification.

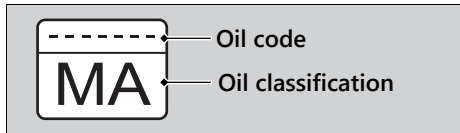

- \*2. The SAE standard grades oils by their viscosity.
- \*3. The API classification specifies the quality and performance rating of engine oils. Use SG or higher oils, excluding oils marked as "Energy Conserving" or "Resource Conserving" on the circular API service symbol.

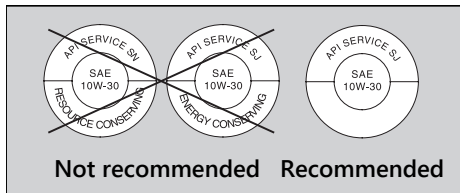

## Brake Fluid

Do not add or replace brake fluid, except in an emergency. Use only fresh brake fluid from a sealed container. If you do add fluid, have the brake system serviced by your dealer as soon as possible.

### NOTICE

Brake fluid can damage plastic and painted surfaces. Wipe up spills immediately and wash thoroughly.

### Recommended brake fluid:

Honda DOT 4 Brake Fluid or equivalent

## Drive Chain

The drive chain must be inspected and lubricated regularly. Inspect the chain more frequently if you often ride on bad roads, ride at high speed, or ride with repeated fast acceleration. ➤ P. 168

If the chain does not move smoothly, makes strange noises, has damaged rollers, has loose pins, has missing O-rings, or kinks, have the chain inspected by your dealer.

Also inspect the drive sprocket and driven sprocket. If either has worn or damaged teeth, have the sprocket replaced by your dealer.

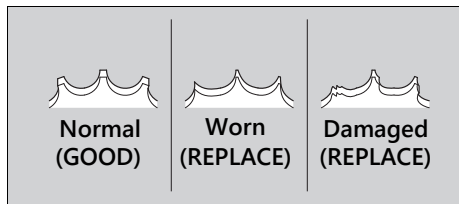
**NOTICE**

Use of a new chain with worn sprockets will cause rapid chain wear.

**Cleaning and Lubricating**

After inspecting the slack, clean the chain and sprockets while rotating the rear wheel. Use a dry cloth with chain cleaner designed specifically for O-ring chains, or neutral detergent. Use a soft brush if the chain is dirty.

After cleaning, wipe dry and lubricate with the recommended lubricant.

**Recommended lubricant:**

Drive chain lubricant designed specifically for O-ring chains  
If not available, use SAE 80 or 90 gear oil.

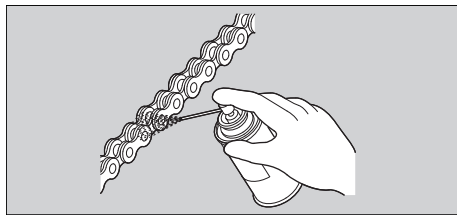

## Maintenance Fundamentals

Do not use a steam cleaner, a high pressure cleaner, a wire brush, volatile solvent such as petrol and benzene, abrasive cleaner, chain cleaner or lubricant NOT designed specifically for O-ring chains as these can damage the rubber O-ring seals.

Avoid getting lubricant on the brakes or tyres. Avoid applying excess chain lubricant to prevent spray onto your clothes and the vehicle.

### Recommended Coolant

**India, Nepal, Hong Kong, Macao**

Use only genuine HONDA PRE-MIX COOLANT without diluting with water. Genuine HONDA PRE-MIX COOLANT is excellent at preventing corrosion and overheating.

The coolant should be inspected and replaced properly by following the maintenance schedule. 📖 P. 129

**Except India, Nepal, Hong Kong, Macao**

Pro Honda HP Coolant is a pre-mixed solution of antifreeze and distilled water.

#### Concentration:

50% antifreeze and 50% distilled water

A concentration of antifreeze below 40% will not provide proper corrosion and cold temperature protection.

A concentration of up to 60% will provide better protection in colder climates.

#### NOTICE

Using coolant not specified for aluminium engines or tap/mineral water can cause corrosion.

## Tyres (Inspecting/Replacing)

### ■ Checking the Air Pressure

Visually inspect your tyres and use an air pressure gauge to measure the air pressure at least once a month or any time you think the tyres look low. Always check air pressure when your tyres are cold.

Even if the direction of the valve stem is changed, do not return it to the original position. Have your vehicle inspected by your dealer.

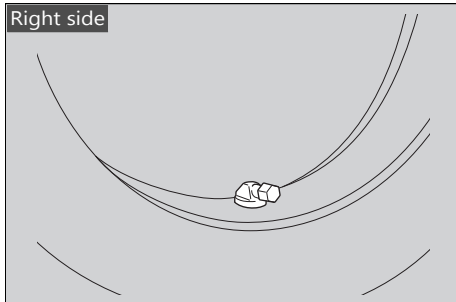

### ■ Inspecting for Damage

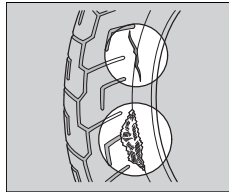

Inspect the tyres for cuts, slits, or cracks that exposes fabric or cords, or nails or other foreign objects embedded in the side of the tyre or the tread.

Also inspect for any unusual bumps or bulges in the side walls of the tyres.

### ■ Inspecting for Abnormal Wear

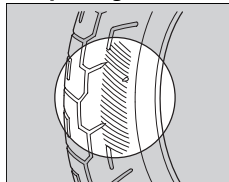

Inspect the tyres for signs of abnormal wear on the contact surface.

### Inspecting Tread Depth

Inspect the tread wear indicators. If they become visible, replace the tyres immediately. For safe riding, you should replace the tyres when the minimum tread depth is reached.

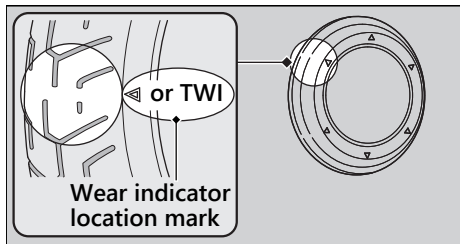

## ⚠️ WARNING

Riding on tyres that are excessively worn or improperly inflated can cause a crash in which you can be seriously hurt or killed.

Follow all instructions in this owner's manual regarding tyre inflation and maintenance.

### Germany

German law prohibits use of tyres whose tread depth is less than 1.6 mm.

Have your tyres replaced by your dealer. For recommended tyres, air pressure and minimum tread depth, see “Specifications.”

➔ P. 241

Follow these guidelines whenever you replace tyres.

- Use the recommended tyres or equivalents of the same size, construction, speed rating, and load range.
- Have the wheel balanced with Honda Genuine balance weights or equivalent after the tyre is installed.
- Do not install a tube inside a tubeless tyre on this vehicle. Excessive heat build-up can cause the tube to burst.
- Use only tubeless tyres on this vehicle. The rims are designed for tubeless tyres, and during hard acceleration or braking, a tube-type tyre could slip on the rim and cause the tyre to rapidly deflate.

## **⚠ WARNING**

Installing improper tyres on your vehicle can adversely affect handling and stability, and can cause a crash in which you can be seriously hurt or killed.

Always use the size and type of tyres recommended in this owner's manual.

### Air Cleaner

#### II GS type

This vehicle is equipped with a viscous type air cleaner element.

Air blow cleaning or any other cleaning can degrade the viscous element performance and cause the intake of dust.

Do not perform the maintenance. Should be serviced by your dealer.

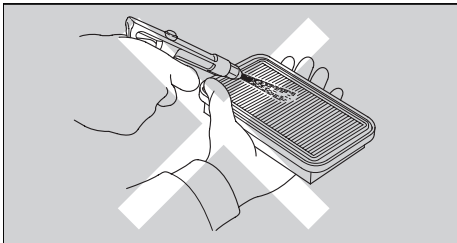



# Tool

The tool kit is stored under the rear seat.

➤ P. 154

You can perform some roadside repairs, minor adjustments and parts replacement with the provided tools.

- 3 mm Hex wrench
- 5 mm Hex wrench

# Removing & Installing Body Components

## Battery

CBR1000ST

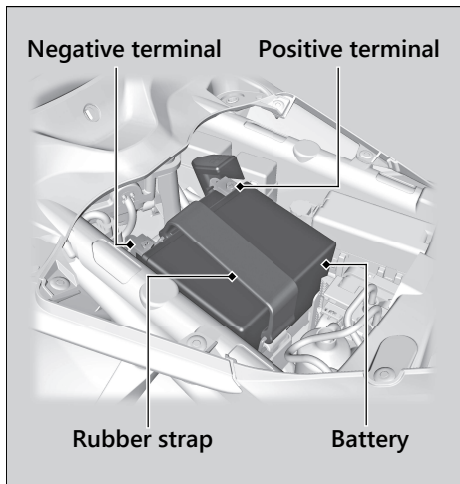

CBR1000SP

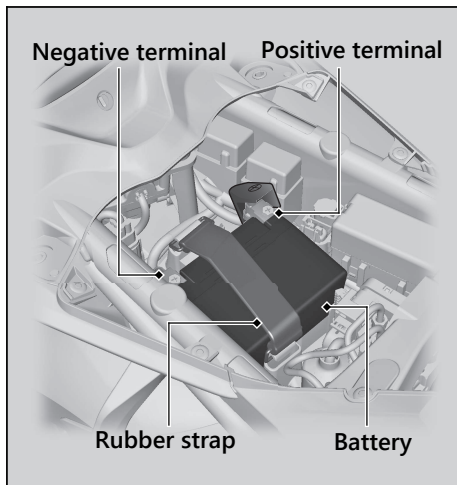

## Removal

Make sure the electrical system is turned off.

1. Remove the front seat. ► P. 153
2. Unhook the rubber strap.
3. Disconnect the negative  $\ominus$  terminal from the battery.
4. Disconnect the positive  $\oplus$  terminal from the battery.
5. Remove the battery taking care not to drop the terminal nuts.

## Installation

Install the parts in the reverse order of removal. Always connect the positive  $\oplus$  terminal first. Make sure that bolts and nuts are tight.

Make sure the clock information is correct after the battery is reconnected. ► P. 84  
For proper handling of the battery, see "Maintenance Fundamentals." ► P. 134  
"Battery Goes Dead." ► P. 218

## Clip

### Removal



1. Press down on the centre pin to release the lock.
2. Pull the clip out of the hole.

### Installation



1. Push the bottom of the centre pin.
2. Insert the clip into the hole.
3. Press down on the centre pin to lock the clip.

## Front Seat

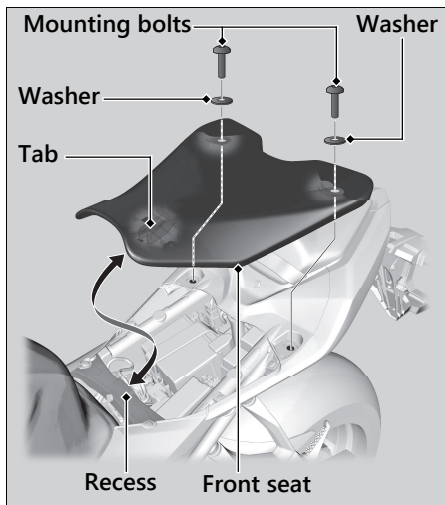

### Removal

Remove the mounting bolts and washers, and then pull the front seat back and up.

### Installation

1. Install the front seat while inserting the tab into the recess.
2. Install the washers and mounting bolts.
3. Tighten the mounting bolts securely. Make sure that the seat is locked securely in position by pulling it up lightly.

## Rear Seat

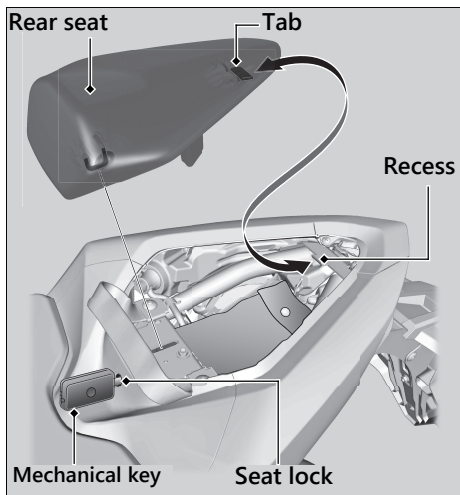

### Removal

1. Insert the mechanical key into the seat lock.
2. Turn the mechanical key clockwise, then pull the rear seat forward and up.

### Installation

1. Insert the tab into the recess.
2. Push down on the front of the rear seat. Make sure that the seat is locked securely in position by pulling it up lightly.

The seat locks automatically when closed. Take care not to lock your key in the compartment under the rear seat.

## Under Cowl

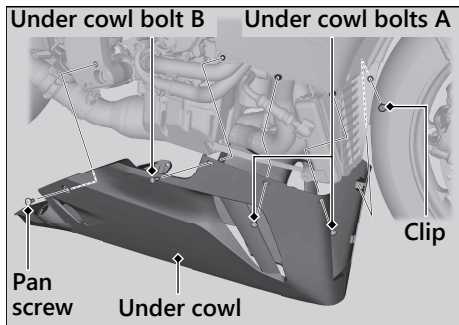
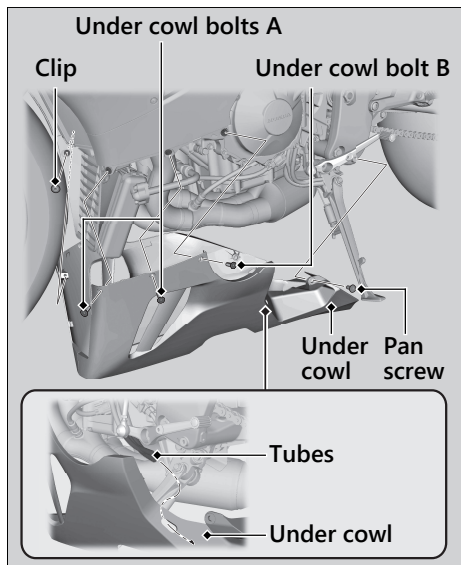

### Removal

1. Remove the clips. ► P. 152
2. Remove the pan screws and under cowl bolts A and B.
3. Remove the under cowl carefully.

## Installation

1. Install the under cowl using reverse of the removal procedure.
2. Route the tubes through the opening of the under cowl.
3. Install and tighten the under cowl bolts A and B securely.

**Torque:** 1.0 N·m (0.1 kgf·m, 0.7 lbf·ft)

4. Install and tighten the pan screws securely.

**Torque:** 10 N·m (1.0 kgf·m, 7 lbf·ft)

5. Install the clips.



## Checking the Engine Oil

1. If the engine is cold, idle the engine for 3 to 5 minutes.
2. Turn off the electrical system to stop the engine, and wait for 2 to 3 minutes.
3. Place your vehicle in an upright position on a firm, level surface.
4. Remove the dipstick and wipe it clean.
5. Insert the dipstick until it seats, but don't screw it in.
6. Check that the oil level is between the upper level and lower level marks on the dipstick.
7. Securely install the dipstick.

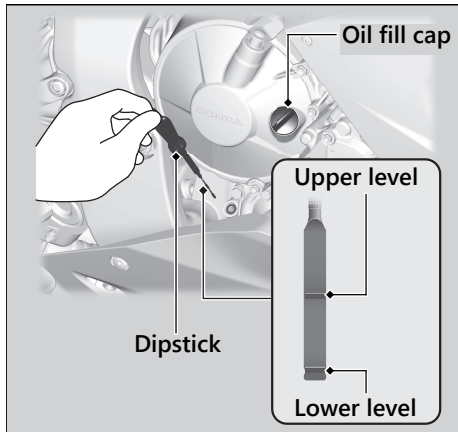

## Adding Engine Oil

---

If the engine oil is below or near the lower level mark, add the recommended engine oil.

► P. 141, ► P. 241

1. Remove the oil fill cap. Add the recommended oil until it reaches the upper level mark.
  - Place your vehicle in an upright position on a firm, level surface when checking the oil level.
  - Do not overfill above the upper level mark.
  - Make sure no foreign objects enter the oil filler opening.
  - Wipe up any spills immediately.

2. Securely reinstall the oil fill cap.

### NOTICE

Overfilling with oil or operating with insufficient oil can cause damage to your engine. Do not mix different brands and grades of oil. They may affect lubrication and clutch operation.

For the recommended oil and oil selection guidelines, see "Maintenance Fundamentals."

► P. 141

## Changing Engine Oil & Filter

Changing the oil and filter requires special tools. We recommend that you have your vehicle serviced by your dealer.

Use a new Honda Genuine oil filter or equivalent specified for your model.

### NOTICE

Using the wrong oil filter can result in serious damage to the engine.

1. Remove the under cowl. ► P. 155
2. If the engine is cold, idle the engine for 3 to 5 minutes.
3. Turn off the electrical system to stop the engine, and wait for 2 to 3 minutes.
4. Place your vehicle on a firm, level surface.

5. Place a drain pan under the drain bolt.
6. Remove the oil fill cap, drain bolt, and sealing washer to drain the oil.

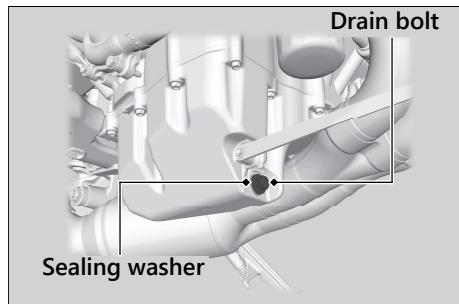

7. Remove the oil filter with a filter wrench and let the remaining oil drain out. Make sure the prior seal is not stuck to the engine.

► Discard the oil and oil filter at an approved recycling centre.

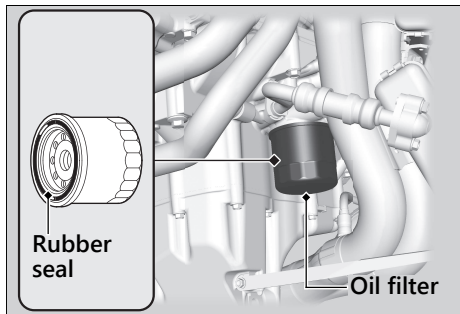

8. Apply a thin coat of engine oil to the rubber seal of a new oil filter.

9. Install the new oil filter and tighten.

**Torque:** 26 N·m (2.7 kgf·m, 19 lbf·ft)

10. Install a new sealing washer onto the drain bolt. Tighten the drain bolt.

**Torque:** 30 N·m (3.1 kgf·m, 22 lbf·ft)

11. Fill the crankcase with the recommended oil (► P. 141, ► P. 241) and install the oil fill cap.

#### Required oil

##### When changing oil & engine oil filter:

3.0 L (3.2 US qt, 2.6 Imp qt)

##### When changing oil only:

2.8 L (3.0 US qt, 2.5 Imp qt)

12. Check the oil level. ► P. 157
13. Check that there are no oil leaks.
14. Install the under cowl.

## Checking the Coolant

---

Check the coolant level in the reserve tank while the engine is cold.

1. Place your vehicle on a firm, level surface.
2. Hold your vehicle in an upright position.
3. Check that the coolant level is between the UPPER level and LOWER level marks on the reserve tank.

If the coolant level is dropping noticeably or the reserve tank is empty, you likely have a serious leak. Have your vehicle inspected by your dealer.

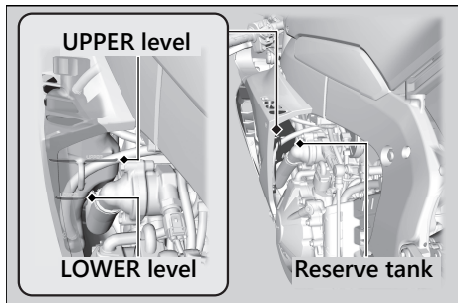

## Adding Coolant

If the coolant level is below the LOWER level mark, add the recommended coolant (► P. 144) until the level reaches the UPPER level mark.

Add fluid only from the reserve tank cap and do not remove the radiator cap.

1. Remove the middle cowl bolts.
2. Pull the middle cowl outward carefully and hook the rib on the stopper of the upper inner panel.

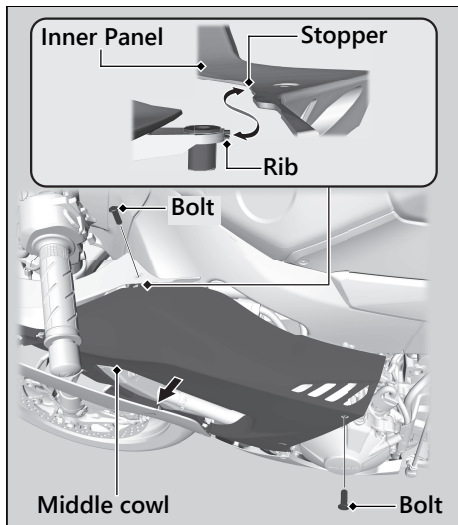

3. Remove the reserve tank cap and add fluid while monitoring the coolant level.
  - Do not overfill above the UPPER level mark.
  - Make sure no foreign objects enter the reserve tank opening.
4. Securely reinstall the reserve tank cap.
5. Install the parts in the reverse order of removal.
  - Tighten the middle cowl bolts.

**Torque:** 1.0 N·m (0.1 kgf·m, 0.7 lbf·ft)

Reserve tank cap

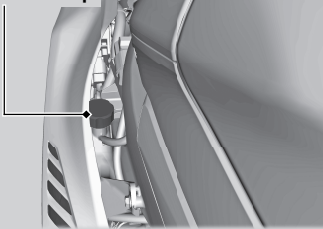

## **⚠ WARNING**

Removing the radiator cap while the engine is hot can cause the coolant to spray out, potentially scalding you.

Always let the engine and radiator cool down before removing the radiator cap.

## **Changing Coolant**

Have your dealer change the coolant unless you have the proper tools and are mechanically qualified.

## Checking Brake Fluid

1. Place your vehicle in an upright position on a firm, level surface.

2. **Except CBR1000SP Front**

Check that the brake fluid reservoir is horizontal and that the fluid level is between the LOWER level and UPPER level marks.

**CBR1000SP Front**

Check that the brake fluid reservoir is

horizontal and that the fluid level is between the MIN and MAX marks.

If the brake fluid level in either reservoir is below the LOWER level mark or MIN mark or the brake lever and pedal freeplay becomes excessive, inspect the brake pads for wear. If the brake pads are not worn, you most likely have a leak. Have your vehicle inspected by your dealer.

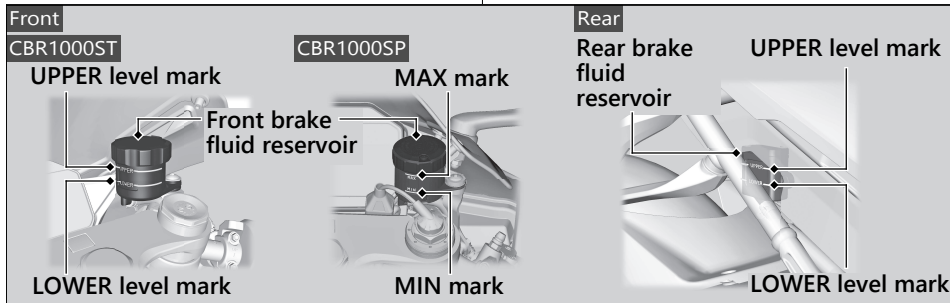



## Inspecting the Brake Pads

Check the condition of the brake pad wear indicators.

The pads need to be replaced if a brake pad is worn to the bottom of the indicator.

1. **Front** Inspect the brake pads from in front of the brake caliper.
  - Always inspect both left and right brake calipers.
2. **Rear** Inspect the brake pads from the underside of the rear of the vehicle.
  - If necessary have the pads replaced by your dealer.
  - Always replace both left and right brake pads at the same time.

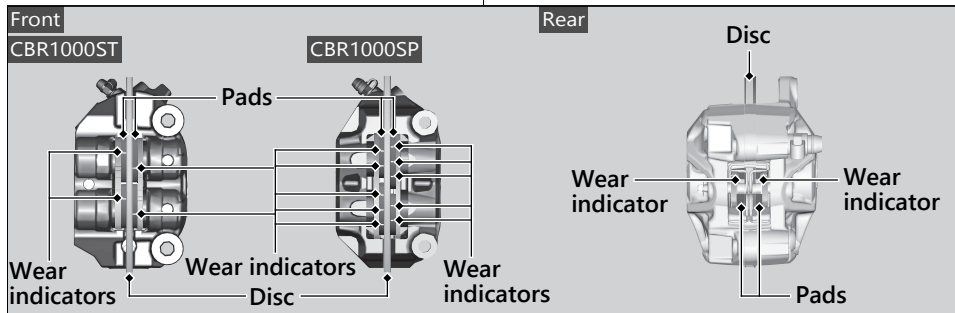

## Adjusting the Brakelight Switch

Check the operation of the brakelight switch. Hold the brakelight switch and turn the adjusting nut in the direction A if the switch operates too late, or turn the nut in the direction B if the switch operates too soon.

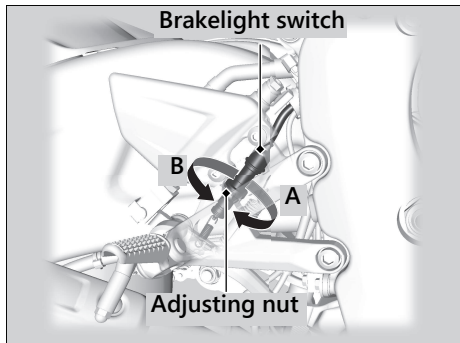

### Checking the Side Stand

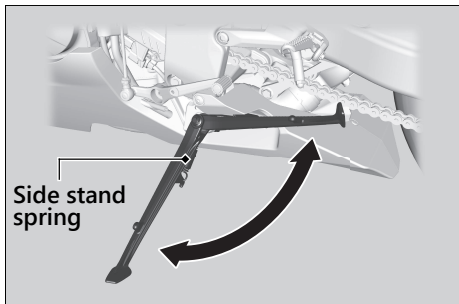

1. Check that the side stand operates smoothly. If the side stand is stiff or squeaky, clean the pivot area and lubricate the pivot bolt with clean grease.
2. Check the spring for damage or loss of tension.
3. Sit on the vehicle, shift the transmission to Neutral, and raise the side stand.
4. Start the engine, pull the clutch lever in, and shift the transmission into gear.
5. Lower the side stand all the way. The engine should stop as you lower the side stand. If the engine doesn't stop, have your vehicle inspected by your dealer.

## Inspecting the Drive Chain Slack

Check the drive chain slack at several points along the chain. If the slack is not constant at all points, some links may be kinked and binding.

Have the chain inspected by your dealer.

1. Shift the transmission to Neutral. Stop the engine.
2. Place your vehicle on its side stand on a firm, level surface.
3. Check the slack in the lower half of the drive chain midway between the sprockets.

### Drive chain slack:

25 - 35 mm (1.0 - 1.4 in)

- ▶ Do not ride your vehicle if the slack exceeds 50 mm (2.0 in).

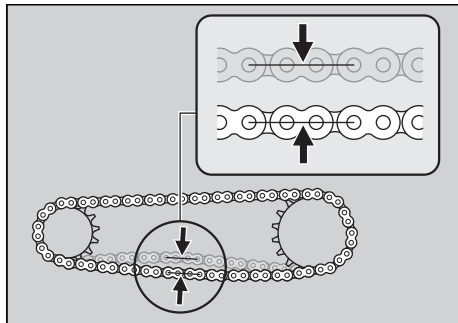

4. Roll the vehicle forward and check that the chain moves smoothly.
5. Inspect the sprockets. ➤ P. 142
6. Clean and lubricate the drive chain. ➤ P. 143

## Adjusting the Drive Chain Slack

Adjusting the chain requires special tools. Have the drive chain slack adjusted by your dealer.

When adjusting the drive chain slack, be careful not to damage the wheel speed sensor and pulser ring.

1. Shift the transmission to Neutral. Stop the engine.
2. Place your vehicle on its side stand on a firm, level surface.
3. Loosen the rear axle nut.
4. Loosen the lock nuts on both adjusting bolts.

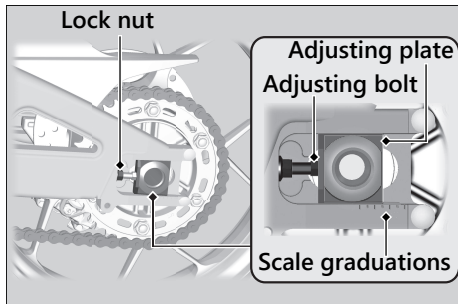
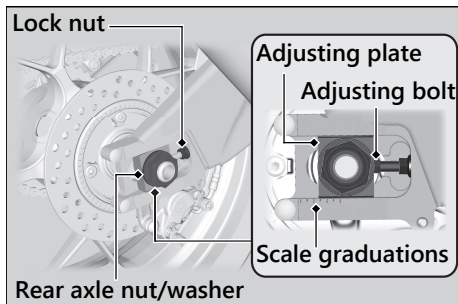

## Drive Chain ► Adjusting the Drive Chain Slack

5. Turn both adjusting bolts an equal number of turns until the correct drive chain slack is obtained. Turn the adjusting bolts counterclockwise to tighten the chain. Turn the adjusting bolts clockwise and push the rear wheel toward the front to provide more slack.

Adjust the slack at a point midway between the drive sprocket and the driven sprocket.

Check the drive chain slack. ➡ P. 168

6. Check rear axle alignment by making sure the end of the chain adjusting plate aligns with the scale graduations on both sides of the swingarm.

Both marks should correspond. If the axle is misaligned, turn the right or left adjusting bolt until the marks are aligned and recheck chain slack.

7. Tighten the rear axle nut.

**Torque:** 135 N·m (13.8 kgf·m, 100 lbf·ft)

8. Hold the adjusting bolts and tighten the lock nuts.
9. Recheck drive chain slack.

If a torque wrench was not used for installation, see your dealer as soon as possible to verify proper assembly. Improper assembly may lead to loss of braking capacity.

## Checking the Drive Chain Wear

Check the chain wear label when adjusting the drive chain. If the rear edge of the adjusting plate enters the red zone on the label after the chain has been adjusted to the proper slack, the chain is excessively worn and must be replaced.

**Chain:** DID525HV3KAI or RK525ROZ8

If necessary have the drive chain replaced by your dealer.

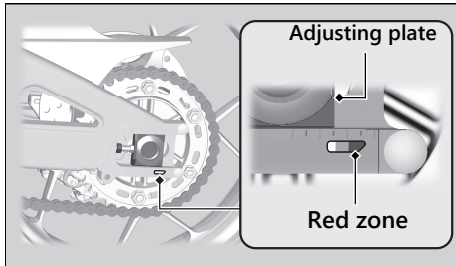

## Checking the Drive Chain Slider

Check the condition of the drive chain slider. The drive chain slider will need to be replaced if the chain slider is worn to the wear limit line.

If necessary have the drive chain slider replaced by your dealer.

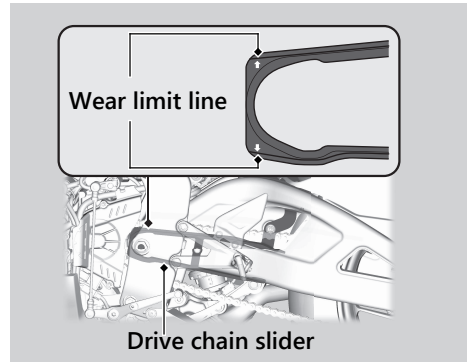

## Checking the Clutch

### Checking the Clutch Lever Freeplay

Check the clutch lever freeplay.

#### Freeplay at the clutch lever:

10 - 20 mm (0.4 - 0.8 in)

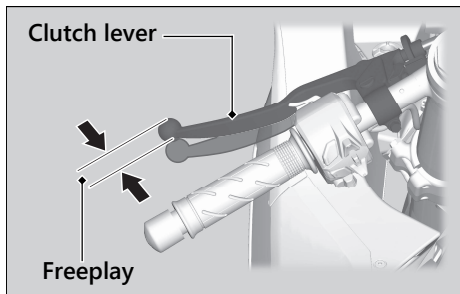

Check the clutch cable for kinks or signs of wear. If necessary have it replaced by your dealer.

Lubricate the clutch cable with a commercially available cable lubricant to prevent premature wear and corrosion.

#### NOTICE

Improper freeplay adjustment can cause premature clutch wear.



## Adjusting the Clutch Lever Freeplay

---

### Upper Adjustment

Attempt adjustment with the upper clutch cable adjuster first.

Turn the clutch cable adjuster until the freeplay is 10 - 20 mm (0.4 - 0.8 in).

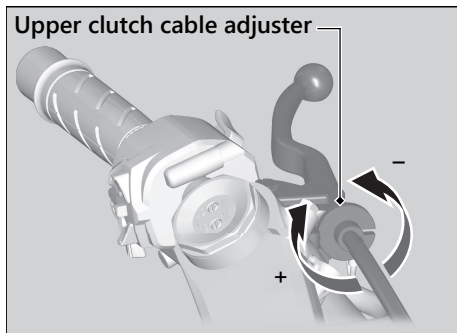

## Lower Adjustment

If the upper clutch cable adjuster is threaded out near its limit, or the correct freeplay cannot be obtained, attempt adjustment with the lower clutch cable adjusting nut.

1. Turn the upper clutch cable adjuster all the way in (to provide maximum freeplay).
2. Loosen the lower lock nut.
3. Turn the adjusting nut until the clutch lever freeplay is 10 - 20 mm (0.4 - 0.8 in).
4. Tighten the lower lock nut and check the clutch lever freeplay.
5. Start the engine, pull the clutch lever in, and shift into gear. Make sure the engine does not stall and the vehicle does not creep. Gradually release the clutch lever and open the throttle. Your vehicle should move smoothly and accelerate gradually.

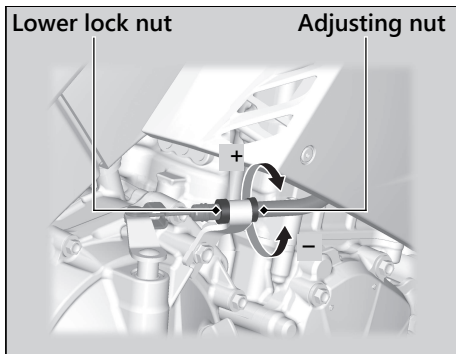

If proper adjustment cannot be obtained or the clutch does not work correctly, see your dealer.

## Checking the Throttle

---

With the engine off, check that the throttle rotates smoothly from fully closed to fully open. If the throttle does not move smoothly, close automatically, have the vehicle inspected by your dealer.

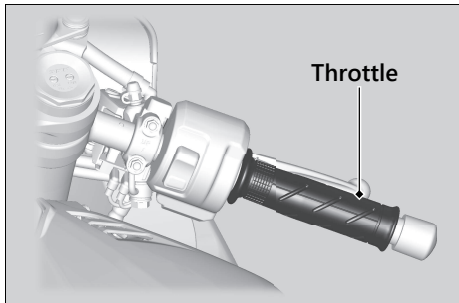

### Adjusting the Headlight Aim

You can adjust vertical aim of the headlight for proper alignment. Turn the knob in or out as necessary.

Obey local laws and regulations.

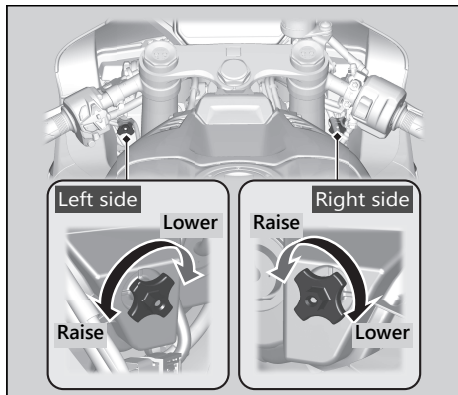

## Adjusting the Brake Lever

You can adjust the distance between the tip of the brake lever and handle grip.

### Adjustment method

#### CBR1000ST

Turn the adjuster until the numbers align with the index mark while pushing the lever forward in the desired position.

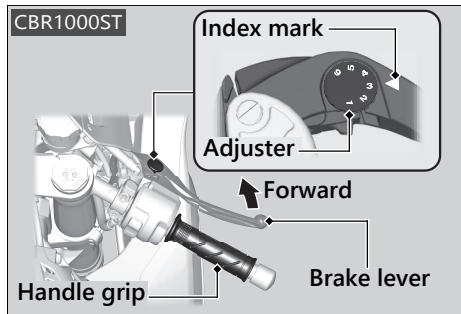

### Other Adjustments ► Adjusting the Brake Lever

#### CBR1000SP

Turn the adjuster clockwise while pushing the lever forward to widen the distance. Turn the adjuster counterclockwise while pushing the lever forward to narrow the distance.

► Make sure the cut-out is seated on the lug.

#### CBR1000SP

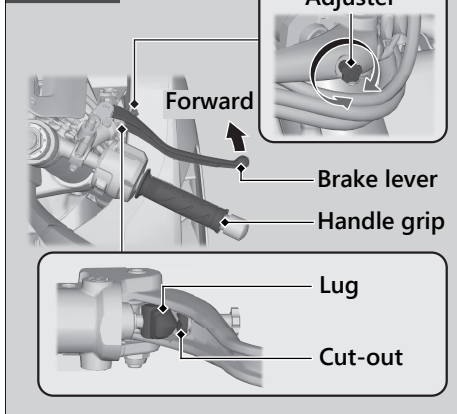

## Other Adjustments ► Adjusting the Brake Lever

After adjustment, check that the lever operates correctly before riding.

### NOTICE

Do not turn the adjuster beyond its natural limit.

## Adjusting the Front Suspension

### Spring Preload

#### CBR1000ST

You can adjust the spring preload by the adjuster to suit the load or the road surface. The spring preload adjuster has 15 turns. Turn clockwise to increase spring preload (hard), or turn counterclockwise to decrease spring preload (soft). The standard position is the 7 1/2 turns from the full soft position.

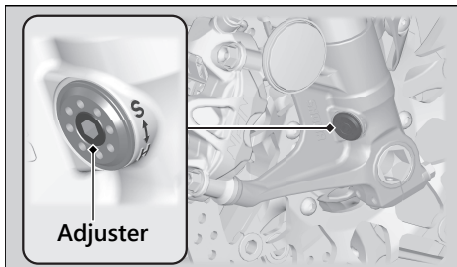

#### NOTICE

Do not turn the adjuster beyond its limits. Adjust both left and right forks to the same spring preload.

## Rebound Damping

### CBR1000ST

You can adjust the rebound damping by the TEN adjuster to suit the load or the road surface.

Turn the adjuster using a suitable tool.

The TEN adjuster has 5 1/2 turns.

Turn clockwise to increase rebound damping (hard), or turn counterclockwise to decrease rebound damping (soft). The standard position is 4 turns from the full hard position.

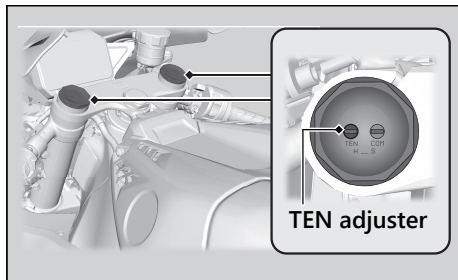

### NOTICE

Do not turn the adjuster beyond its limits. Adjust both left and right forks to the same rebound damping.



## Compression Damping

### CBR1000ST

You can adjust the compression damping by the COM adjuster to suit the load or the road surface.

Turn the adjuster using a suitable tool.

The COM adjuster has 7 turns.

Turn clockwise to increase compression damping (hard), or turn counterclockwise to decrease compression damping (soft). The standard position is 5 turns from the full hard position.

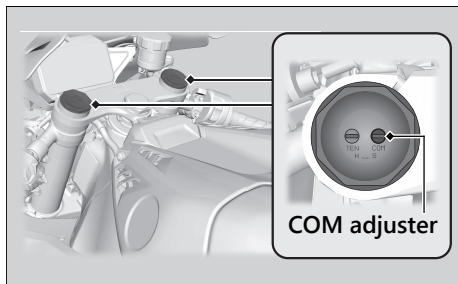

### NOTICE

Do not turn the adjuster beyond its limits. Adjust both left and right forks to the same compression damping.

## Adjusting the Rear Suspension

### Spring Preload

CBR1000ST

You can adjust the spring preload by the adjuster to suit the load or the road surface. Turn the adjuster using a suitable tool. The preload adjuster has 10 positions. Positions 1 to 3 are for a decrease spring preload (soft), or turn the position 5 to 10 increase spring preload (hard). The standard position is 4.

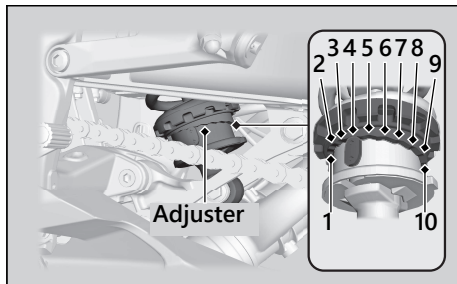

#### NOTICE

Do not turn the adjuster beyond its limits. Attempting to adjust directly from 1 to 10 or 10 to 1 may damage the shock absorber.

#### NOTICE

The rear shock absorber damper unit contains high pressure nitrogen gas. Do not attempt to disassemble, service, or improperly dispose of the damper. See your dealer.

## Rebound Damping

### CBR1000ST

You can adjust the rebound damping by the TEN adjuster to suit the load or the road surface.

Turn the adjuster using a suitable tool.

The TEN adjuster has 4 turns.

Turn clockwise to increase rebound damping (hard), or turn counterclockwise to decrease rebound damping (soft).

The standard position is 2 turns from the full hard position.

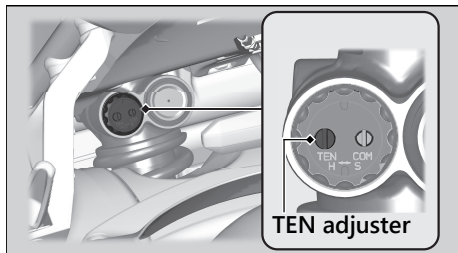

#### NOTICE

Do not turn the adjuster beyond its limits.

#### NOTICE

The rear shock absorber damper unit contains high pressure nitrogen gas. Do not attempt to disassemble, service, or improperly dispose of the damper. See your dealer.

## I Compression Damping

### CBR1000ST

You can adjust the compression damping by the COM adjuster to suit the load or the road surface.

Turn the adjuster using a suitable tool.

The COM adjuster has 4 1/2 turns.

Turn clockwise to increase compression damping (hard), or turn counterclockwise to decrease compression damping (soft).

The standard position is 2 1/4 turns from the full hard position.

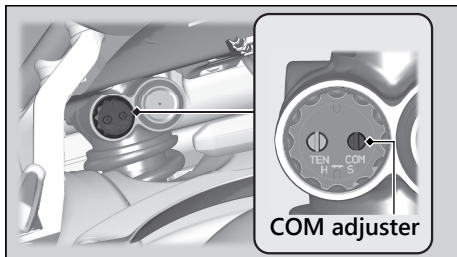

#### NOTICE

Do not turn the adjuster beyond its limits.

#### NOTICE

The rear shock absorber damper unit contains high pressure nitrogen gas. Do not attempt to disassemble, service, or improperly dispose of the damper. See your dealer.

## Adjusting the ÖHLINS Smart EC System

---

### CBR1000SP

This model is equipped with the ÖHLINS Smart EC system.

This system consists of front and rear suspension and Suspension Control Unit (SCU).

This system provides the pre-programmed damping characteristics optimized for different situation to the front and rear suspension.

SCU constantly determines riding conditions from vehicle information. As a result, this system provides the optimum rebound and compression damping characteristics.

The system continually adjusts compression and rebound damping levels according to the riding situation.

You can adjust the front and rear suspension preload manually.

ÖHLINS Smart EC is a trademark of ÖHLINS RACING AB, Sweden.

## Front Spring Preload

You can adjust the spring preload by the adjuster to suit the load or the road surface.

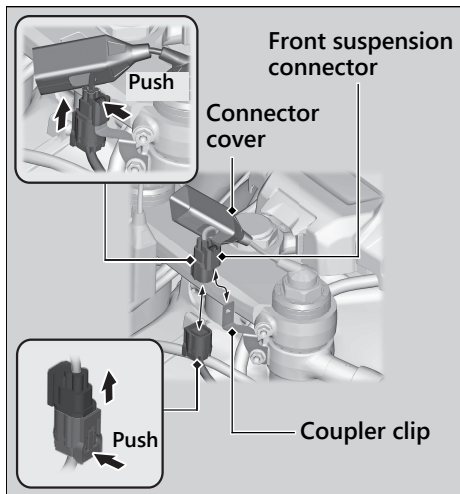

1. Make sure the electrical system is turned off.
2. Slide the connector cover, and then disconnect the front suspension connector from the coupler clip.
3. Disconnect the front suspension connector.
  - Do not remove by pulling on the wire harness.

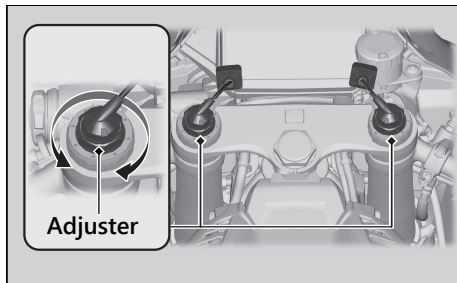

4. Turn clockwise to increase spring preload (hard), or turn counterclockwise to decrease spring preload (soft).  
The standard position is the 2 turns from the full soft position.

**NOTICE**

Do not turn the adjuster beyond its limits. Adjust both left and right forks to the same spring preload.

5. After the adjustment, connect the front suspension connector.
  - Be careful not to allow water or dust to enter the connector.
  - Make sure to install the connector completely.

6. Connect the front suspension connector to the coupler clip and then install the connector cover.

## ■ Rear Spring Preload

You can adjust the spring preload by the adjuster knob to suit the load or the road surface.

Turn clockwise to increase spring preload (hard), or turn counterclockwise to decrease spring preload (soft).

The standard position is 8 turns from the full hard position.

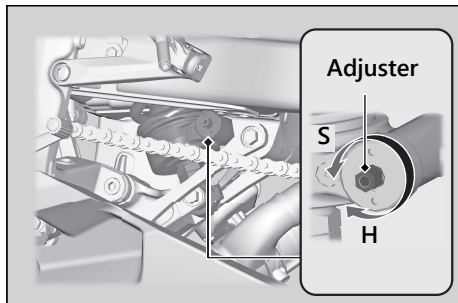

### NOTICE

Do not turn the adjuster beyond its limits.



## I Damping Adjustment

You can select A-mode which automatically adjusts damping according to the riding situation and MANUAL mode which allows damping to be set at a fixed level.

### A-mode

A-mode will automatically adjust compression and rebound damping levels for the front and rear suspension according to the current vehicle conditions.

A-mode provides 3 situation (TRACK, SPORT and RAIN) with different riding feel and vehicle characteristics for various situations. A-mode has 3 modes (A1, A2, A3), and each mode can select the situation suitable for the riding condition.

Defaults of A-mode can be adjusted using the ÖHLINS Objective Based Tuning interface (OBTi).

"OBTi" provides the interface where the rider can adjust the settings in order to enhance the vehicle characteristics to rider's preferences.

Adjustable OBTi support items and riding situations.

Situation	OBTi support items				
	FRONT	REAR	BRAKE	ACC	CORNER
TRACK	A	A	A	A	A
SPORT	A	A	A	N/A	N/A
RAIN	A	A	A	N/A	N/A

A : Adjustable

N/A : Not adjustable

## Other Adjustments ► Adjusting the ÖHLINS Smart EC System

### FRONT/REAR:

By adjusting the front and rear firmness objective, it is possible to increase(+) or decrease(-) the front and rear suspension total damping level.

Direction

For TRACK

(+): More stable feeling. Good for high grip tyre and high road surface temperature.

(-): Useful to increase weight transfer. Good setting for low grip condition. Adjusting the parameters separately allows changing the front and rearing balance separately.

For SPORT/RAIN

(+): More stable feeling. Good for controlling the suspension movement moderately.

(-): More comfort feeling. Good setting for bumpy road and wet condition.

Adjusting the parameters separately allows changing the front and rearing balance separately.

### BRAKE:

By adjusting the brake support objective it is possible to increase (+) or decrease (-) the pitching resistance during initial braking.

Direction

(+): Front fork compresses slowly.

(-): Front fork compresses quickly.

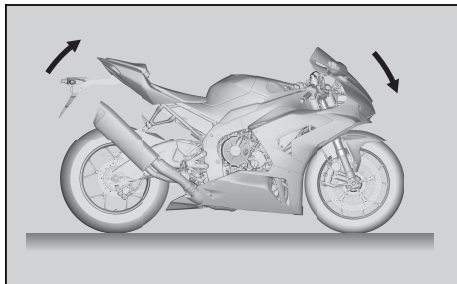

### ACC (TRACK only):

By adjusting the acceleration objective it is possible to increase (+) or decrease (-) the pitching resistance during accelerating.

Direction

(+): More stable feeling especially during hard acceleration out of corner.

(-): Useful to increase weight transfer to increase rear tyre load.

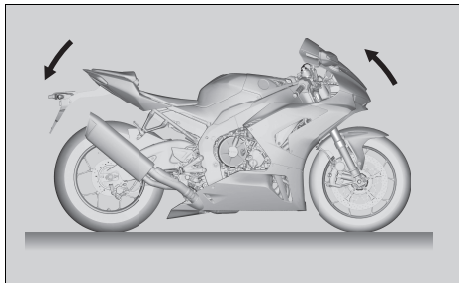

### CORNER (TRACK only):

By adjusting the corner objective it is possible to increase (+) or decrease (-) the agile movements of the while turning.

Direction

(+): More agility especially in middle of corner.

(-): Good setting for rain or low grip condition.

**To adjust the "FRONT", "REAR", "BRAKE", "ACC" and "CORNER".** 📖 P. 63

📖 P. 68

**To select the S mode.** 📖 P. 109

## MANUAL mode

The suspension setting can be fixed at a certain value on compression and rebound damping of the front and rear suspensions.

There is no automatic adjustment function for the front and rear suspension damping.

MANUAL mode provides 3 modes (M1, M2 and M3).

Preset of M1 is suitable for track riding.

Preset of M2 is suitable for winding roads.

Preset of M3 is suitable for street riding.

In MANUAL mode, the following damping levels can be adjusted as desired:

FR COM: Compression damping for front suspension

FR REB: Rebound damping for front suspension

RR COM: Compression damping for rear suspension

RR REB: Rebound damping for rear suspension

**To adjust the “FR COM”, “FR REB”, “RR COM” and “RR REB”.** ► P. 63 ► P. 69

**To select the S mode.** ► P. 109

### Replacing the Honda SMART Key Battery

---

If the Honda SMART Key indicator flashes 5 times when the electrical system is turned on, or the operating range becomes unstable, replace the battery as soon as possible. We recommend to see your dealer for this service.

**Battery type:** CR2032

1. With the emblem upward, separate the Honda SMART Key by inserting a coin or a flat head screwdriver covered with a protective cloth into the slit.
  - ▶ Wrap a coin or a screwdriver with a protective cloth to prevent scratching the Honda SMART Key.
  - ▶ Do not touch the circuit or terminal. This may cause problems.
  - ▶ Be careful to avoid scratching the waterproof covering or allowing dust to enter.
  - ▶ Do not forcibly dismantle the Honda SMART Key body.

## Other Replacement ► Replacing the Honda SMART Key Battery

2. Replace the old battery with a new one with the positive (+) side facing up.
3. Assemble the parts in the reverse order of disassembly.

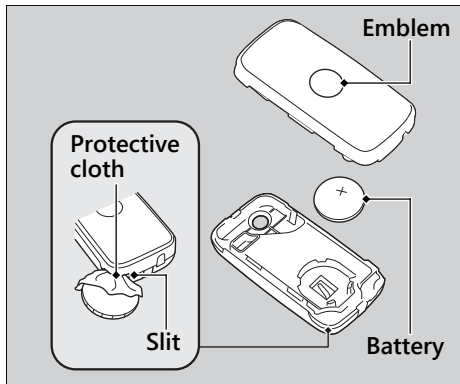

## ⚠️ WARNING

### **Chemical Burn Hazard: do not swallow battery.**

If swallowed, the battery can cause severe internal burns and even death.

- Keep battery away from children and battery compartment securely closed.
- If the battery compartment does not close securely, stop using the product and keep it away from children.
- Immediately seek medical attention if a child may have swallowed battery.

# Troubleshooting

<b>Engine Will Not Start</b> .....	P. 196
<b>Overheating (High coolant temperature indicator is on)</b> .....	P. 197
<b>Warning Indicators On or Flashing</b> .....	P. 198
Low Oil Pressure Indicator .....	P. 198
PGM-FI (Programmed Fuel Injection) Malfunction Indicator Lamp (MIL).....	P. 198
ABS (Anti-lock Brake System) Indicator .....	P. 199
HESD (Honda Electronic Steering Damper) Indicator .....	P. 199
Torque Control Indicator.....	P. 200
Honda SMART Key Indicator .....	P. 201
<b>When the Honda SMART Key System Does Not Operate Properly</b> .....	P. 202

<b>Activating the Electrical System in an Emergency</b> .....	P. 204
<b>Tyre Puncture</b> .....	P. 209
<b>Electrical Trouble</b> .....	P. 218
Battery Goes Dead.....	P. 218
Burned-out Light Bulb .....	P. 219
Blown Fuse.....	P. 220

## Starter Motor Operates But Engine Does Not Start

---

Check the following items:

- Check the correct engine starting sequence. ➤ P. 115
- Check that there is petrol in the fuel tank.
- Check if the PGM-FI malfunction indicator lamp (MIL) is on.
  - ▶ If the indicator lamp is on, contact your dealer as soon as possible.

## Starter Motor Does Not Operate

---

Check the following items:

- Check the correct engine starting sequence. ➤ P. 115
- Check for a blown fuse. ➤ P. 220
- Check for a loose battery connection (➤ P. 150) or battery terminal corrosion (➤ P. 137).
- Check the condition of the battery. ➤ P. 218

If the problem continues, have your vehicle inspected by your dealer.



## Overheating (High coolant temperature indicator is on)

The engine is overheating when the following occurs:

- High coolant temperature indicator comes on.
- Acceleration becomes sluggish.  
If this occurs, pull safely to the side of the road and perform the following procedure.

Extended fast idling may cause the high coolant temperature indicator to come on.

### NOTICE

Continuing to ride with an overheated engine can cause serious damage to the engine.

1. Stop the engine using the ignition switch, and then push the ignition **I** (On) switch to turn on the electrical system.
2. Check that the radiator fan is operating, and then turn the electrical system off.  
**If the fan is not operating:**  
Suspect a fault. Do not start the engine. Transport your vehicle to your dealer.  
**If the fan is operating:**  
Allow the engine to cool with the electrical system turned off.
3. After the engine has cooled, inspect the radiator hose and check if there is a leak.  
**➤ P. 161**  
**If there is a leak:**  
Do not start the engine. Transport your vehicle to your dealer.
4. Check the coolant level in the reserve tank. **➤ P. 161**  
**▶ Add coolant as necessary.**
5. If 1-4 check normal, you may continue riding, but closely monitor the high coolant temperature indicator.

## Low Oil Pressure Indicator

---

If the low oil pressure indicator comes on, pull safely to the side of the road and stop the engine.

### NOTICE

Continuing to ride with low oil pressure can cause serious damage to the engine.

1. Check the engine oil level, and add oil as necessary. 📄 P. 157, 📄 P. 158
2. Start the engine.
  - ▶ Only continue riding if the low oil pressure indicator goes off.

Rapid acceleration may momentarily cause the low oil pressure indicator to come on, especially if the oil is at or near the low level. If the low oil pressure indicator stays on when the oil level is at the proper level, stop the engine and contact your dealer.

If the engine oil level goes down rapidly, your vehicle may have a leak or another serious problem. Have your vehicle inspected by your dealer.

## PGM-FI (Programmed Fuel Injection) Malfunction Indicator Lamp (MIL)

---

If the indicator comes on while riding, you may have a serious problem with the PGM-FI system. Reduce speed and have your vehicle inspected by your dealer as soon as possible.

## **ABS (Anti-lock Brake System) Indicator**

---

If the indicator operates in one of the following ways, you may have a serious problem with the ABS. Reduce your speed and have your vehicle inspected by your dealer as soon as possible.

- Indicator comes on or starts flashing while riding.
- Indicator does not come on when the electrical system is turned on.
- Indicator does not go off at speeds above 10 km/h (6 mph).

If the ABS indicator stays on, your brakes will continue to work as a conventional system, but without the anti-locking function.

The ABS indicator may flash if you turn the rear wheel while the rear wheel is lifted off the ground. In this case, turn the electrical system off and on again. The ABS indicator will go off after your speed reaches 30 km/h (19 mph).

## **HESD (Honda Electronic Steering Damper) Indicator**

---

If the indicator comes on while riding, you may have a serious problem with the HESD. Reduce speed and have your vehicle inspected by your dealer as soon as possible.

## Torque Control Indicator

---

If the indicator operates in one of the following ways, you may have a serious problem with the Torque Control. Reduce your speed and have your vehicle inspected by your dealer as soon as possible.

- Indicator comes and stays on (solid) while riding.
- Indicator does not come on when the electrical system is turned on.
- Indicator does not go off at speeds above 5 km/h (3 mph).

Even when the Torque Control indicator is on, your vehicle will have normal riding ability without Torque Control function.

- When the indicator comes on while the Torque Control is in operation, you will have to completely close the throttle to regain normal riding ability.

The Torque Control indicator may come on if you rotate the rear wheel while your vehicle is lifted off the ground. In this case, turn the electrical system off and on again. The Torque Control indicator will go off after your speed reaches 5 km/h (3 mph).

## Honda SMART Key Indicator

---

### When the Honda SMART Key indicator flashes 5 times

**Replacing the Honda SMART Key Battery** ► P. 193

### When the Honda SMART Key indicator is flashing while the electrical system is on

The Honda SMART Key indicator flashes when communication between your vehicle and Honda SMART Key stops after turning on the electrical system.

It is probably caused by the following:

- Strong radio waves or noise are affecting the system
- You lose the Honda SMART Key while riding

However, this does not affect the operation of your vehicle until the electrical system is off.

You may not be able to turn off the electrical system when losing the Honda SMART Key while riding, or if the battery is low, or because the system is affected by strong radio waves or noise. If this occurs, turn the ignition switch knob  (Off/Lock) counterclockwise and hold it until the electrical system shut off.

You can also turn off the electrical system by turning the ignition switch knob  (Off/Lock) counterclockwise 3 times within 3 seconds.

If the electrical system cannot be turned on because the Honda SMART Key battery becomes weak (or dead), it can be activated by means of emergency procedures. ► P. 204

## When the Honda SMART Key System Does Not Operate Properly

When the Honda SMART Key system does not work properly, perform the following.

- Check that the Honda SMART Key system is activated.

Lightly push the ON/OFF button on the Honda SMART Key.

If the LED of the Honda SMART Key is red, switch the Honda SMART Key system to activation. ➤ P. 105

If the LED of the Honda SMART Key does not respond, replace the battery of the Honda SMART Key.

- Check that there is no communication failure in the Honda SMART Key system. The Honda SMART Key system uses low-intensity radio waves. The Honda SMART Key system may not work properly in the following environments:
  - ▶ When there are facilities nearby that generate strong radio waves or noise such as TV towers, power stations, radio stations, or airports.
  - ▶ When you carry the Honda SMART Key with a laptop or wireless communication device such as a radio or mobile phone.
  - ▶ When the Honda SMART Key comes into contact with or is covered by metal objects.

## When the Honda SMART Key System Does Not Operate Properly

- Check that a registered Honda SMART Key is used.  
Use a registered Honda SMART Key. The Honda SMART Key system cannot be activated without a registered Honda SMART Key.
- Make sure that you do not use a broken Honda SMART Key.  
If you use a broken Honda SMART Key, the Honda SMART Key system cannot be activated. Bring the ID tag to your dealer.

- Check the battery condition and battery lead in your vehicle.  
Check the battery and battery terminals. If the battery is weak, contact your dealer.

If the Honda SMART Key system cannot be activated due to other causes, contact your dealer.

# Activating the Electrical System in an Emergency

The mechanical key can be used to activate the electrical system when the electric system cannot be turned on because the Honda SMART Key battery becomes weak or dead.

## Set up to ID number input mode

1. Remove the front seat using a 5 mm Hex wrench provided in the tool kit.
  - ▶ To access the tool kit, remove the rear seat. ▣ P. 154
2. Remove the fuse box cover. ▣ P. 220
3. Pull out the SMART ECU fuse with the fuse puller in the tool kit and wait about 2 minutes before insert the SMART ECU fuse again.
4. Push and hold the ignition **I** (On) switch for more than 4 seconds.
  - ▶ The steering lock indicator comes on and the system enters the ID number input mode.

5. Check the ID number on the ID tag.

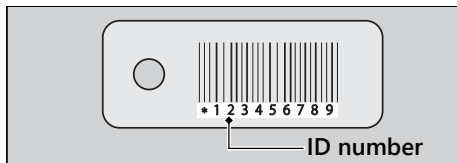
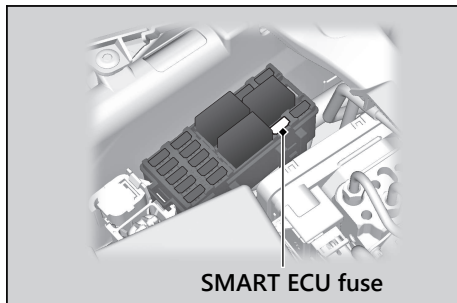



## || ID number input

You can input your ID number by pushing the ignition **|** (On) switch and Turn the ignition switch knob **○/🔒** (Off/Lock) counterclockwise. Input the ID number on the ID tag in order from the left in turn by pushing the ignition **|** (On) switch.



The ID number is input according to the number of times the ignition **|** (On) switch is pushed.

Push the ignition **|** (On) switch the desired number of times, then turn the ignition switch knob **○/🔒** (Off/Lock) counterclockwise to fix the current digit (the steering lock indicator goes off briefly and comes on again), and input the next digit, and then repeat until all the digits are input.



While inputting the ID number, if the button is not pressed for about 60 seconds, the inputted ID number is cancelled and the system returns to the state before removing the SMART ECU fuse (the steering lock indicator goes off).

## Activating the Electrical System in an Emergency

### Example:

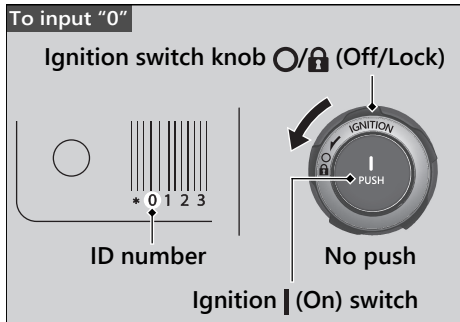
- To input "0", turn the ignition switch knob  (Off/Lock) counterclockwise without pushing the ignition  (On) switch, and then input next digit.



- To input "1", push the ignition  (On) switch once, and then turn the ignition switch knob  (Off/Lock) counterclockwise to input the next digit.

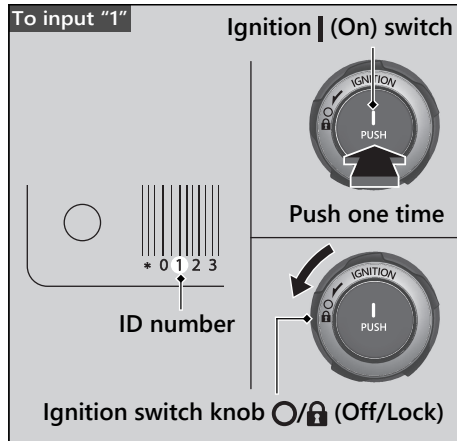

### **ID number input success**

After the last digit of the ID number is inputted, ID number is authenticated, the steering lock indicator will flash every 2 seconds.

Push the ignition **I** (On) switch within 30 seconds after the ID number is authenticated.

### **If the steering is locked**

The steering will be unlocked. To active the electrical system, push the ignition **I** (On) switch once again within 30 seconds after the ID number is authenticated.

### **If the steering is unlocked**

The electrical system will be activated. You can start the engine.

You can turn off the engine and electrical system and also lock the steering using the ignition switch. The ignition switch operation is disabled 30 seconds after the electrical system is turned off.

To activate the electrical system again, repeat the procedures for activating the electrical system in an emergency.

## Activating the Electrical System in an Emergency

### ID number input failure

If the ID number is not authenticated after inputting, the steering lock indicator goes off. The steering cannot be unlocked and the electrical system will not activate.

Repeat the procedures for activating the electrical system in an emergency.

### ID number input cancel

If you input the wrong number, you can cancel ID number input by not operating the switch for about 60 seconds (the steering lock indicator goes off).

Repeat the procedures for activating the electrical system in an emergency.

## Tyre Puncture

Repairing a puncture or removing a wheel requires special tools and technical expertise. We recommend you have this type of service performed by your dealer.

After an emergency repair, always have the tyre inspected/replaced by your dealer.

### Emergency Repair Using a Tyre Repair Kit

---

If your tyre has a minor puncture, you can make an emergency repair using a tubeless tyre repair kit.

Follow the instructions provided with the emergency tyre repair kit.

Riding your vehicle with a temporary tyre repair is very risky. Do not exceed 50 km/h (30 mph). Have the tyre replaced by your dealer as soon as possible.

### **⚠ WARNING**

Riding your vehicle with a temporary tyre repair can be risky. If the temporary repair fails, you can crash and be seriously injured or killed.

If you must ride with a temporary tyre repair, ride slowly and carefully and do not exceed 50 km/h (30 mph) until the tyre is replaced.

### Removing Wheels

---

Follow these procedures if you need to remove a wheel in order to repair a puncture.

## Tyre Puncture ► Removing Wheels

When removing and installing the wheel, be careful not to damage the wheel speed sensor and pulser ring.

### Front Wheel

#### Removal

1. Place your vehicle on a firm, level surface.
2. Cover the both side of the front wheel and brake caliper with protective tape or cloth.
3. Release the harness guide from the brake hose.

CBR1000ST

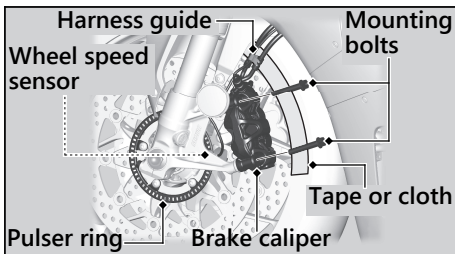

CBR1000SP

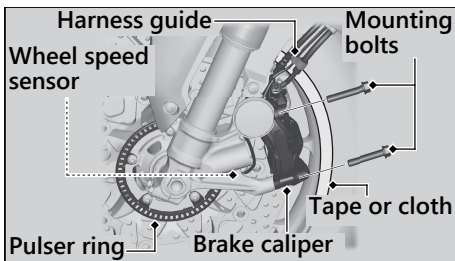

4. On the right side, remove the mounting bolts and remove the brake caliper.
5. On the left side, remove the mounting bolts and remove the brake caliper.
  - Support the brake caliper assembly so that it doesn't hang from the brake hose. Do not twist the brake hose.
  - Avoid getting grease, oil, or dirt on the disc or pad surfaces.
  - Do not pull the front brake lever while the brake caliper is removed.
  - Take care to prevent the brake caliper from scratching the wheel during removal.
6. Loosen the left axle pinch bolts.
7. Remove the front axle bolt.
8. Support your vehicle securely and raise the front wheel off the ground using a maintenance stand or a hoist.

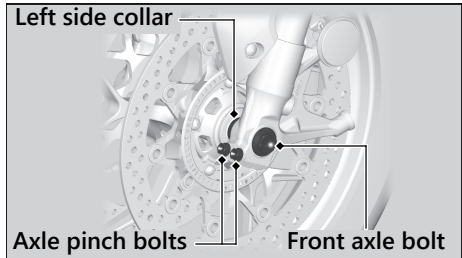
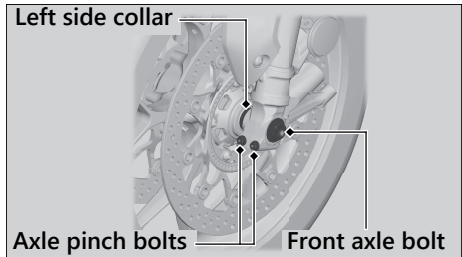
**CBR1000ST****CBR1000SP**

## Tyre Puncture ► Removing Wheels

- Loosen the right axle pinch bolts.
- On the right side, withdraw the front axle shaft, and remove the side collars and wheel.

CBR1000ST

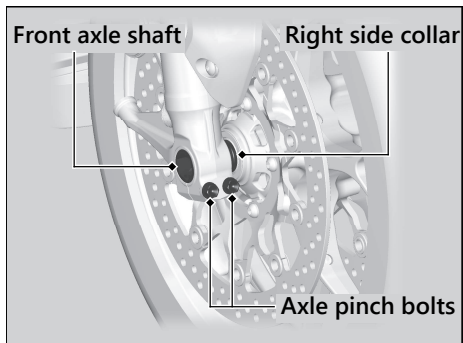

CBR1000SP

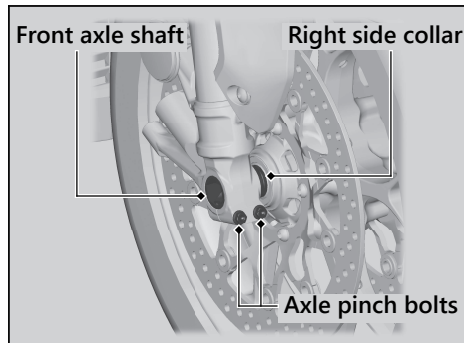



## Installation

1. Attach the side collars to the wheel.
2. On the right side, place the wheel between the fork legs and insert the lightly greased front axle shaft to the end, through the right fork leg and wheel hub.
3. Align the end of the front axle shaft with the surface of the fork leg.

### CBR1000ST

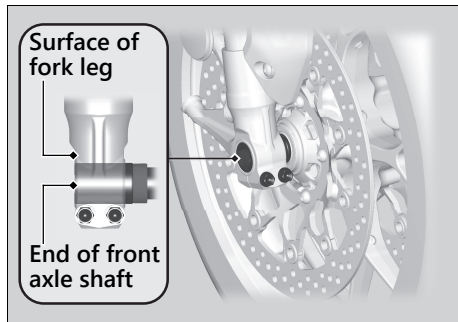

### CBR1000SP

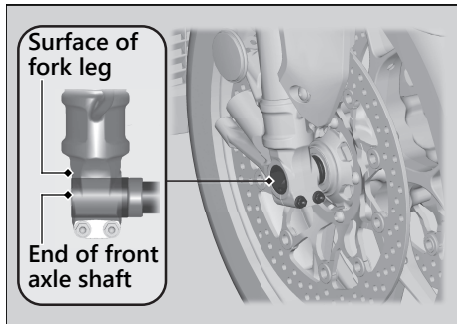

4. Tighten the right axle pinch bolts to hold the axle.
5. Tighten the axle bolt.

**Torque:** 79 N·m (8.1 kgf·m, 58 lbf·ft)

6. Loosen the right axle pinch bolts.
7. Tighten the left axle pinch bolts.

**Torque:** 22 N·m (2.2 kgf·m, 16 lbf·ft).

**Tyre Puncture ► Removing Wheels**

8. Install the left brake caliper and tighten the mounting bolts.

**Torque:** 40 N·m (4.1 kgf·m, 30 lbf·ft).

9. Install the right brake caliper and tighten the mounting bolts.

**Torque:** 40 N·m (4.1 kgf·m, 30 lbf·ft).

- Take care to prevent the brake caliper from scratching the wheel during installation.
- Use new mounting bolts when installing the brake caliper.

**NOTICE**

When installing a wheel or caliper into original position, carefully fit the brake disc between the pads to avoid scratching them.

10. Lower the front wheel on the ground.
11. Apply the brake lever several times. Then, pump the fork several times.

12. Retighten the right axle pinch bolts.

**Torque:** 22 N·m (2.2 kgf·m, 16 lbf·ft).

13. Raise the front wheel off the ground again, and check that the wheel rotates freely after you release the brake.
14. Install the harness guide.
15. Uncover the protective tape or cloth.

If a torque wrench was not used for installation, see your dealer as soon as possible to verify proper assembly. Improper assembly may lead to loss of braking capacity.

## ■ Rear Wheel

### Removal

1. Place your vehicle on a firm, level surface.
2. Support your vehicle securely and raise the rear wheel off the ground using a maintenance stand or a hoist.
3. Loosen the rear axle nut, lock nuts and turn the adjusting bolts so the rear wheel can be moved all the way forward for maximum drive chain slack.
4. Remove the rear axle nut and washer.

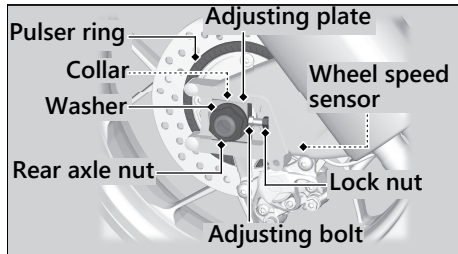

5. Remove the drive chain from the driven sprocket by pushing the rear wheel forward.
6. Remove the rear axle shaft and adjusting plates.

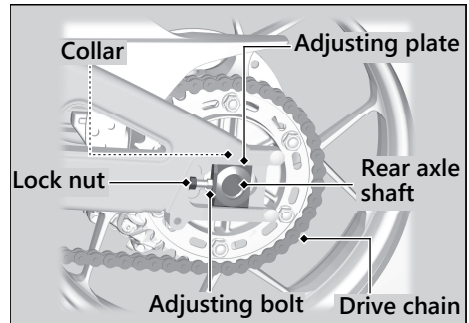

## Tyre Puncture ► Removing Wheels

7. Remove the brake caliper bracket, rear wheel and side collars.
  - Support the brake caliper assembly so that it doesn't hang from the brake hose. Do not twist the brake hose.
  - Avoid getting grease, oil, or dirt on the disc or pad surfaces.
  - Do not push the brake pedal while the wheel is removed.

## Installation

1. To install the rear wheel, reverse the removal procedure.
  - Take care to prevent the brake caliper from scratching the wheel during installation.

### NOTICE

When installing a wheel or caliper into original position, carefully fit the brake disc between the pads to avoid scratching them.

2. Make sure that the lug on the brake caliper bracket is positioned in the slot on the swingarm.

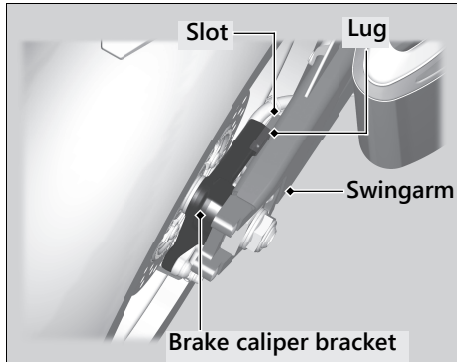

3. Adjust the drive chain. ► P. 169
4. Install and tighten the rear axle nut.

**Torque:** 135 N·m (13.8 kgf·m, 100 lbf·ft).

5. After installing the wheel, apply the brake pedal several times, then check if the wheel rotates freely. Recheck the wheel if the brake drags or if the wheel does not rotate freely.

If a torque wrench was not used for installation, see your dealer as soon as possible to verify proper assembly. Improper assembly may lead to loss of braking capacity.

## Battery Goes Dead

---

### CBR1000ST

Charge the battery using a motorcycle battery charger.

Remove the battery from the vehicle before charging.

Do not use an automobile-type battery charger, as these can overheat a motorcycle battery and cause permanent damage. If the battery does not recover after recharging, contact your dealer.

### NOTICE

Jump starting using an automobile battery can damage your vehicle's electrical system and is not recommended.

### CBR1000SP

Battery charging is needed.

A battery charger recommended by your lithium-ion (li-ion) battery manufacturer is needed for battery charging.

Contact your dealer before charging the battery.

Remove the battery from the vehicle before charging.

### NOTICE

Only use a charger recommended by your lithium-ion (li-ion) battery manufacturer. Using a battery charger that is not recommended can cause permanent damage to your battery.

If the battery does not recover after recharging, contact your dealer.

### NOTICE

Do not jump-start, as this can damage your vehicle's electrical system and battery.

## Burned-out Light Bulb

All light bulbs on the vehicle are LEDs. If there is an LED which is not turned on, see your dealer for servicing.

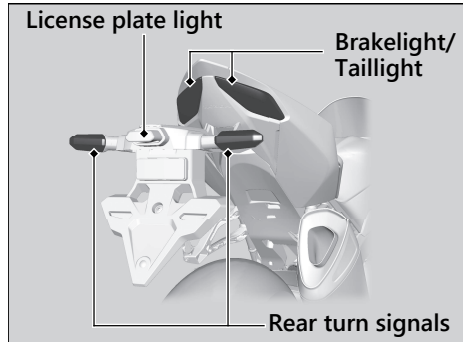
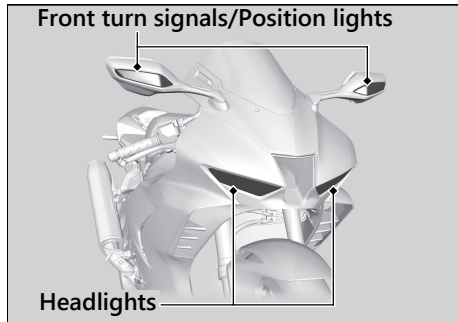

## Blown Fuse

Before handling fuses, see "Inspecting and Replacing Fuses." ► P. 141

### Fuse Box Fuses

1. Remove the front seat. ► P. 153
2. Remove the fuse box cover.
3. Pull the main fuse and other fuses out one by one with the fuse puller furnished in reverse side of the fuse box cover and check for a blown fuse. Always replace a blown fuse with a spare fuse of the same rating.
  - Spare fuses are provided on back side of the fuse box cover.
4. Reinstall the fuse box cover.
5. Reinstall the front seat.

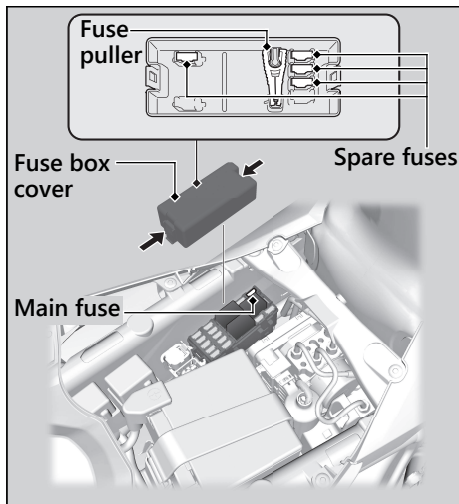

#### NOTICE

If a fuse fails repeatedly, you likely have an electrical problem. Have your vehicle inspected by your dealer.



# Information

Service Diagnostic Recorders.....	P. 222
Keys.....	P. 223
Instruments, Controls, & Other Features...	P. 227
Caring for Your Vehicle.....	P. 229
Storing Your Vehicle.....	P. 234
Transporting Your Vehicle .....	P. 235
You & the Environment .....	P. 235
Serial Numbers .....	P. 237
Fuels Containing Alcohol .....	P. 238
Catalytic Converter .....	P. 239

## Service Diagnostic Recorders

Your vehicle is equipped with service-related devices that record information about powertrain performance and driving conditions. The data can be used to help technicians diagnose, repair and maintain the vehicle. This data may not be accessed by anyone else except as legally required or with the permission of the vehicle owner.

However this data may be accessed by Honda, its authorised dealers and authorised repairers, employees, representatives and contractors only for the purpose of the technical diagnosis, research and development of the vehicle.

# Keys

## Honda SMART Key

The Honda SMART Key is equipped with a mechanical key.

Carrying the Honda SMART Key allows you to perform the following operations:

- Locking or unlocking the steering and activating or deactivating the electrical system
- Opening the fuel fill cap and rear seat

The ID number of the Honda SMART Key is on the ID tag. You can also unlock the steering (if it is locked) and activating the electrical system by inputting the ID number.

Always carry the ID tag, but separate from the Honda SMART Key, to avoid losing all of them at the same time.

Also store the key tag and a copy of your ID number in a safe place other than your vehicle.

The Honda SMART Key contains electronic circuits. If the circuits are damaged, the Honda SMART Key will not allow you to perform any operations.

- Do not drop the Honda SMART Key or set heavy objects on them.
- Protect the Honda SMART Key from direct sunlight, high temperature, and high humidity.
- Do not scratch or puncture.
- Do not store near any magnetized products such as a magnetized key chain.
- Always keep the Honda SMART Key away from electric appliances such as a TV, radio, PC or low-frequency massage device.
- Keep the Honda SMART Key away from liquids. If it gets wet, dry it immediately with a soft cloth.
- Keep the Honda SMART Key away from the vehicle while washing the vehicle.
- Do not burn.
- Do not wash in the ultrasonic cleaner.

## Keys

- If fuel, wax, or grease adhere to the Honda SMART Key, wipe it off immediately to avoid cracking or warping.
- Do not disassemble the Honda SMART Key other than when changing a battery. Only the cover of the Honda SMART Key can be disassembled. Do not disassemble other parts.
- Do not lose your Honda SMART Key. If you lose it, you will need to register a new Honda SMART Key. See your dealer with your ID tag for registration.

The battery in the Honda SMART Key system normally lasts about 2 years.

Do not keep mobile phones or other radio transmitting devices in any compartment. The radio frequency from the devices will interrupt the Honda SMART Key system.

To get an additional Honda SMART Key, take the Honda SMART Key and the vehicle to your dealer.

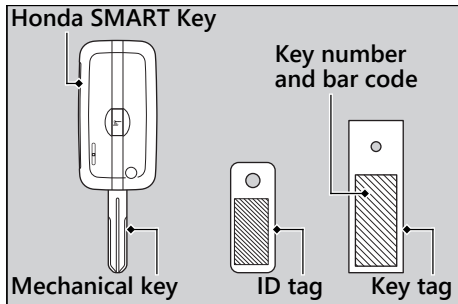

**EU Directive**

This Honda SMART Key system complies with the RE (Radio Equipment) Directive (2014/53/EU).



The declaration of conformity to RE Directive is provided to the owner at the time of purchase. The declaration of conformity should be kept at a safe place. When the declaration of conformity is lost or is not provided, contact your dealer.

Manufacturer  
Honda Lock Mfg. Co., Ltd.  
Postal address  
3700 Shimonaka, Sadowara-Cho, Miyazaki-Shi,  
Miyazaki, 880-0293, Japan

Importer  
Honda Motor Europe Ltd - Aalst Office  
Wijngaardveld 1 (Noord V) 9300 Aalst - Belgium  
HONDA TURKIYE A.S. SEKERPINAR MAHALLESİ  
YANYOL SOKAK. NO:1 41420, CAYIROVA /  
KOCAELI / TURKEY

Hereby, Honda Lock Mfg. Co., Ltd. declares that the radio equipment type HLSS-5 is in compliance with Directive 2014/53/EU. The full text of the EU declaration of conformity is available at the following internet address:  
[http://www.hondalock.co.jp/eu\\_doc/hlss-5.pdf](http://www.hondalock.co.jp/eu_doc/hlss-5.pdf)

Operational frequency band  
FOB 433.87MHz-433.97MHz  
ECU 125kHz  
Maximum Output Power  
FOB 10mW(e.r.p.)  
ECU 148.8dBµV/m@3m

## Keys

### Bahrain only

Manufacturer

Honda Lock Mfg. Co., Ltd.

Model name

HLSS-5

### Vietnam only



# Instruments, Controls, & Other Features

## Ignition Switch

Leaving the electrical system on with the engine stopped will drain the battery.

Do not operate the ignition switch while riding.

## Engine Stop Switch

Do not use the engine stop switch except in an emergency. Doing so when riding will cause the engine to suddenly turn off, making riding unsafe.

If you stop the engine using the engine stop switch, turn the ignition switch knob  (Off/Lock) counterclockwise to turn off the electrical system. Failing to do so will drain the battery.

## Odometer

The display locks at 999,999 when the read-out exceeds 999,999.

## Tripmeter

The tripmeters return to 0.0 when each read-out exceeds 9,999.9.

## Owner's manual

The owner's manual, registration, and insurance information can be stored in the tool bag under the rear seat.  P. 126

### Ignition Cut-off System

IMU (Inertial Measurement Unit) sensor automatically stops the engine and fuel pump if the vehicle falls over. To reset the IMU, you must turn the electrical system off and back to on before the engine can be restarted.

If a failure of the IMU is detected, the engine and fuel pump will not stop automatically when the vehicle falls over.

### HESD

The Honda Electronic Steering Damper (HESD) automatically controls the steering damper characteristics in accordance with vehicle speed and acceleration.

**HESD Indicator Comes On** ➤ P. 199

### Assist-slipper Clutch System

The assist-slipper clutch system helps to prevent the rear tyre from locking up when the deceleration of your vehicle produces a strong engine braking effect. It also makes the clutch lever operation feel lighter.

Use only MA classification engine oil for your vehicle. Using engine oil other than MA classification oil could result in damage to the assist-slipper clutch system.

### Throttle by Wire System

This model is equipped with a Throttle by Wire System.

Do not put magnetized items or items susceptible to magnetic interference near the right handlebar switches.



### Automatic Brightness Control

The backlight brightness of the meter will be controlled automatically when "AUTO" is selected on the brightness setting.

Ambient brightness is detected by the photosensor.

Do not damage or cover the photosensor.

Otherwise, the automatic brightness control may not work properly.

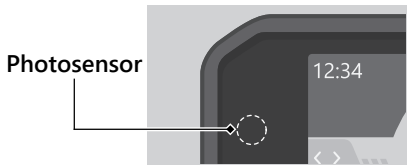

## Caring for Your Vehicle

Frequent cleaning and polishing is important to ensure the life of your Honda. A clean vehicle makes it easier to spot potential problems. In particular, seawater and salts used to prevent ice on roads promote the formation of corrosion. Always wash your vehicle thoroughly after riding on coastal or treated roads.

### Washing

Allow the engine, muffler, brakes, and other high-temperature parts to cool before washing.

1. Rinse your vehicle thoroughly using a low pressure garden hose to remove loose dirt.
2. If necessary, use a sponge or a soft towel with mild cleaner to remove road grime.
  - ▶ Clean the windscreen, headlight lens, panels, and other plastic components with extra care to avoid scratching them. Avoid directing water into the air cleaner, muffler, and electrical parts.

## Caring for Your Vehicle

3. Thoroughly rinse your vehicle with plenty of clean water and dry with a soft, clean cloth.
4. After the vehicle dries, lubricate any moving parts.
  - ▶ Make sure that no lubricant spills onto the brakes or tyres. Brake discs, pads, drum or shoes contaminated with oil will suffer greatly reduced braking effectiveness and can lead to a crash.
5. Lubricate the drive chain immediately after washing and drying the vehicle.
6. Apply a coat of wax to prevent corrosion.
  - ▶ Avoid products that contain harsh detergents or chemical solvents. These can damage the metal, paint, and plastic on your vehicle. Keep the wax clear of the tyres and brakes.
  - ▶ If your vehicle has any mat painted parts, do not apply a coat of wax to the mat painted surface.

## Washing Precautions

Follow these guidelines when washing:

- Do not use high-pressure washers:
  - ▶ High-pressure water cleaners can damage moving parts and electrical parts, rendering them inoperable.
  - ▶ Water in the air intake can be drawn into the throttle body and/or enter the air cleaner.
- Do not direct water at the muffler:
  - ▶ Water in the muffler can prevent starting and causes rust in the muffler.
- Dry the brakes:
  - ▶ Water adversely affects braking effectiveness. After washing, apply the brakes intermittently at low speed to help dry them.
- Do not direct water under the seat:
  - ▶ Water in the under seat compartment can damage your documents and other belongings.

- Do not direct water at the air cleaner:
  - ▶ Water in the air cleaner can prevent the engine from starting.
- Do not direct water near the headlight:
  - ▶ The headlight's inside lens may fog temporarily after washing or while riding in the rain. This does not impact the headlight function.  
However, if you see a large amount of water or ice accumulated inside the lens(es), have your vehicle inspected by your dealer.
- Do not use wax or polishing compounds on mat painted surface:
  - ▶ Use a soft cloth or sponge, plenty of water, and a mild detergent to clean mat painted surfaces. Dry with a soft clean cloth.

### Aluminium Components

Aluminium will corrode from contact with dirt, mud, or road salt. Clean aluminium parts regularly and follow these guidelines to avoid scratches:

- Do not use stiff brushes, steel wool, or cleaners containing abrasives.
- Avoid riding over or scraping against curbs.

### Panels

Follow these guidelines to prevent scratches and blemishes:

- Wash gently using a soft sponge and plenty of water.
- To remove stubborn stains, use diluted detergent and rinse thoroughly with plenty of water.
- Avoid getting petrol, brake fluid, or detergents on the instruments, panels, or headlight.

### Windscreen

Using plenty of water, clean the windscreen with a soft cloth or sponge. (Avoid using detergents or any kind of chemical cleaner on the windscreen.) Dry with a soft, clean cloth.

#### NOTICE

To avoid possible scratching or other damage, use only water and a soft cloth or sponge to clean the windscreen.

For a dirtier windscreen, use a diluted neutral detergent with a sponge and plenty of water. Make sure to wash off all the detergent. (Detergent residue may cause windscreen cracks.)

Replace the windscreen if scratches cannot be removed and they obstruct clear vision.

Take care to keep battery electrolyte, brake fluid, or other chemical solvents off the windscreen and screen garnish. They will damage the plastic.

## Exhaust Pipe and Muffler

The exhaust pipe and muffler are titanium and stainless steel but may become stained by mud or dust.

The part in the following illustration is coated to prevent oxidation.

To avoid damaging the coating, do not use aggressive chemical cleaners or compounds.

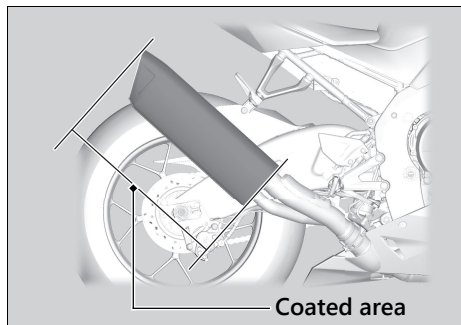

### Coated area

To remove mud or dust, use a wet sponge and a mild detergent, then rinse well with clean water. Dry with chamois or a soft towel.

Use a soft cloth sprayed with a multi-purpose spray lubricant and wipe clean.

### Uncoated area

To remove mud or dust, use a wet sponge and a liquid kitchen abrasive, then rinse well with clean water. Dry with chamois or a soft towel.

If necessary, remove heat stains by using a commercially available fine texture compound. Then rinse by the same manner as removing mud or dust.

### NOTICE

Even though the exhaust is made of titanium and stainless steel, it can become stained. Remove all marks and blemishes as soon as they are noticed.

## Storing Your Vehicle

If you store your vehicle outdoors, you should consider using a full-body cover.

If you won't be riding for an extended period, follow these guidelines:

- Wash your vehicle and wax all painted surfaces (except mat painted surfaces). Coat chrome pieces with rust-inhibiting oil.
- Lubricate the drive chain. ➤ P. 143
- Place your vehicle on a maintenance stand and position a block so that both tyres are off the ground.
- After rain, remove the body cover and allow the vehicle to dry.

- Remove the battery (➤ P. 150) to prevent discharge. Fully charge the battery and then place it in a shaded, well-ventilated area.
  - ▶ If you leave the battery in place, disconnect the negative ⊖ terminal to prevent discharge.

After removing your vehicle from storage, inspect all maintenance items required by the Maintenance Schedule.

## Transporting Your Vehicle

If your vehicle needs to be transported, it should be carried on a motorcycle trailer or a flatbed truck or trailer that has a loading ramp or lifting platform, and motorcycle tie-down straps. Never try to tow your vehicle with a wheel or wheels on the ground.

**NOTICE**

Towing your vehicle can cause serious damage to the transmission.

## You & the Environment

Owning and riding a vehicle can be enjoyable, but you must do your part to protect the environment.

**Choose Sensible Cleaners**

Use a biodegradable detergent when you wash your vehicle. Avoid aerosol spray cleaners that contain chlorofluorocarbons (CFCs) which damage the atmosphere's protective ozone layer.

### Recycle Wastes

Put oil and other toxic wastes in approved containers and take them to a recycling centre. Call your local or state office of public works or environmental services to find a recycling centre in your area, and to get instructions on how to dispose of non-recyclable wastes. Do not place used engine oil in the trash, or pour it down a drain or on the ground. Used oil, petrol, coolant, and cleaning solvents contain poisons that can hurt refuse workers and contaminate drinking water, lakes, rivers, and oceans.



## Serial Numbers

The frame and engine serial numbers uniquely identify your vehicle and are required in order to register your vehicle. They may also be required when ordering replacement parts. You should record these numbers and keep them in a safe place.

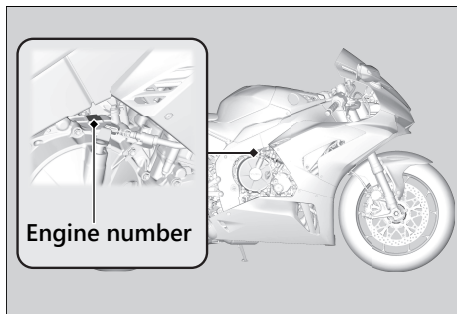
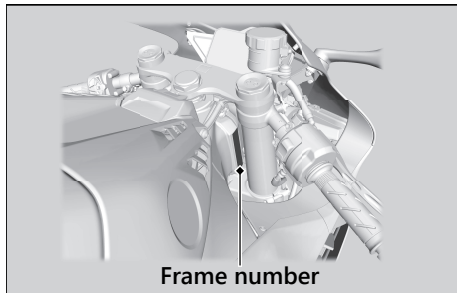

## Fuels Containing Alcohol

Some conventional fuels blended with alcohol are available in some locales to help reduce emissions to meet clean air standards. If you plan to use blended fuel, check that it is unleaded and meets the minimum octane rating requirement.

The following fuel blends can be used in your vehicle:

- Ethanol (ethyl alcohol) up to 10% by volume.
  - ▶ Petrol containing ethanol may be marketed under the name Gasohol.

The use of petrol containing more than 10% ethanol may:

- Damage the painting of the fuel tank.
- Damage the rubber tubes of the fuel line.
- Cause corrosion of the fuel tank.
- Cause poor drivability.

### NOTICE

Use of blended fuels containing higher than approved percentages can damage metal, rubber, plastic parts of your fuel system.

If you notice any undesirable operating symptoms or performance problems, try a different brand of petrol.

## Catalytic Converter

This vehicle is equipped with a three-way catalytic converter. The catalytic converter contains precious metals that serve as catalysts in high temperature chemical reactions that convert hydrocarbons (HC), carbon monoxide (CO), and oxides of nitrogen (NO<sub>x</sub>) in the exhaust gasses into safe compounds.

A defective catalytic converter contributes to air pollution and can impair your engine's performance. A replacement unit must be an original Honda part or equivalent.

Follow these guidelines to protect your vehicle's catalytic converter.

- Always use unleaded petrol. Leaded petrol will damage the catalytic converter.
- Keep the engine in good running condition.
- Have your vehicle serviced if your engine is misfiring, backfiring, stalling, or otherwise not running properly, stop riding and turn off the engine.

# Specifications

## ■ Main Components

Overall length	2,100 mm (82.7 in)
Overall width	745 mm (29.3 in)
Overall height	1,140 mm (44.9 in)
Wheelbase	1,455 mm (57.3 in)
Minimum ground clearance	115 mm (4.5 in)
Caster angle	24° 00'
Trail	102 mm (4.0 in)
Curb weight	201 kg (443 lb)
Maximum weight capacity *1	180 kg (397 lb)
Maximum luggage weight *2	(ED, II ED type) 14 kg (31 lb)
Passenger capacity	Rider and 1 passenger
Minimum turning radius	3.80 m (12.47 ft)
Displacement	1,000 cm <sup>3</sup> (61.0 cu-in)
Bore x stroke	81.0 x 48.5 mm (3.19 x 1.91 in)
Compression ratio	13.2:1
Fuel	(ED, II ED, U, II U type) Unleaded petrol 95 RON or higher
	(II GS type) Unleaded petrol Recommended: 95 RON or higher

Fuel containing alcohol	ETHANOL up to 10 % by volume
Tank capacity	16.1 L (4.25 US gal, 3.54 Imp gal)
Battery	<b>CBR1000ST</b> YTZ7S 12 V-6 Ah (10 HR) / 12 V-6.3 Ah (20 HR)
	<b>CBR1000SP</b> HY85S lithium-ion (li-ion) 12 V-2.0 Ah (20 HR)
Gear ratio	1st 2.615
	2nd 2.058
	3rd 1.700
	4th 1.478
	5th 1.333
	6th 1.214
Reduction ratio (primary / final)	1.630 / 2.500

\*1: Including rider, passenger, all luggages, and accessories

\*2: Includes the weight of the luggage and added accessories.

## ■ Service Data

Tyre size	Front	120/70ZR17M/C (58W)
	Rear	200/55ZR17M/C (78W)
Tyre type	Radial, tubeless	
Recommended Tyre	Front	BRIDGESTONE RS11F
		PIRELLI DIABLO SUPERCORSA SP V3
	Rear	BRIDGESTONE RS11R N
		PIRELLI DIABLO SUPERCORSA SP V3 E
Tyre category of use *1	Normal	Permitted
	Special	Not Permitted
	Snow	Not Permitted
	Moped	Not Permitted
Tyre air pressure	Front	250 kPa (2.50 kgf/cm <sup>2</sup> , 36 psi)
	Rear	290 kPa (2.90 kgf/cm <sup>2</sup> , 42 psi)
Minimum tread depth	Front	1.5 mm (0.06 in)
	Rear	2.0 mm (0.08 in)
Spark plug	(standard) SILMAR10C9S (NGK)	
Spark plug gap	0.80 - 0.90 mm (0.031 - 0.035 in)	
Idle speed	1,400 ± 100 rpm	
Recommended engine oil	Honda 4-stroke motorcycle oil API Service Classification SG or higher, excluding oils marked as "Energy Conserving" or "Resource Conserving," SAE 10W-30, JASO T 903 standard MA	

Engine oil capacity	After draining	2.8 L (3.0 US qt, 2.5 Imp qt)
	After draining & engine oil filter change	3.0 L (3.2 US qt, 2.6 Imp qt)
	After disassembly	4.0 L (4.2 US qt, 3.5 Imp qt)
Recommended brake fluid	Honda DOT 4 Brake Fluid	
Cooling system capacity	2.29 L (2.42 US qt, 2.01 Imp qt)	
Recommended coolant	<b>India, Nepal, Hong Kong, Macao</b> <b>Except India, Nepal, Hong Kong, Macao</b>	HONDA PRE-MIX COOLANT Pro Honda HP Coolant
Recommended drive chain lubricant	Drive chain lubricant designed specifically for O-ring chains If not available, use SAE 80 or 90 gear oil.	
Drive chain slack	25 - 35 mm (1.0 - 1.4 in)	
Standard drive chain	DID525HV3KAI or RK525ROZ8	
	No. of links	118
Standard sprocket size	Drive sprocket	16T
	Driven sprocket	40T

\*1: EU regulation

## Specifications

### ■ Bulbs

Headlight	LED
Brakelight/Taillight	LED
Front turn signal / Position light	LED
Rear turn signal	LED
License plate light	LED

### ■ Fuses

Main fuse	30 A
Other fuse	30 A, 15 A, 10 A, 7.5A

### ■ Torque Specifications

Under cowl bolt	1.0 N·m (0.1 kgf·m, 0.7 lbf·ft)
Under cowl pan screw	10 N·m (1.0 kgf·m, 7 lbf·ft)
Oil filter	26 N·m (2.7 kgf·m, 19 lbf·ft)
Engine oil drain bolt	30 N·m (3.1 kgf·m, 22 lbf·ft)
Middle cowl bolt	1.0 N·m (0.1 kgf·m, 0.7 lbf·ft)
Rear wheel axle nut	135 N·m (13.8 kgf·m, 100 lbf·ft)
Front wheel axle bolt	79 N·m (8.1 kgf·m, 58 lbf·ft)
Front wheel axle pinch bolt	22 N·m (2.2 kgf·m, 16 lbf·ft)
Front wheel brake caliper mounting bolt	40 N·m (4.1 kgf·m, 30 lbf·ft)

**A**

ABS (Anti-lock Brake System).....	16
ABS (Anti-lock Brake System) Indicator .....	94, 199
ABS Mode Indicator .....	55
Accessories .....	20
Activating the Electrical System in an Emergency .....	204
Air Cleaner.....	148
Assist-slipper Clutch System.....	228

**B**

Battery .....	5, 136, 150
Brakelight Switch.....	166
Brakes	
Fluid .....	142, 164
Lever Adjustment.....	177
Pad Wear .....	165
Braking .....	15
Brightness.....	229
Button	
Horn .....	98
Start.....	100

**C**

Catalytic Converter.....	239
Clutch System.....	172
Coolant .....	144, 161
Coolant Temperature Gauge .....	51

**D**

Damping Adjustment .....	189
Drive Chain.....	168

**E**

EB Value .....	111
Electrical Trouble .....	218
Emergency Stop Signal .....	122
Engine	
Number .....	237
Oil .....	141, 157
Oil Filter .....	159
Overheats .....	197
Starting .....	115
Stop Switch .....	100, 115, 227
Stopping .....	227
Will Not Start .....	196
Environment .....	235

**Equipment**

Owner's Manual .....	126
Tool Kit .....	126, 149

**F**

Flooded Engine .....	116
Frame Number .....	237
Front Seat .....	153
Front Suspension .....	179

**Fuel**

Recommended .....	124
Tank Capacity .....	124

Fuels Containing Alcohol .....	238
Fuses .....	141, 220

**G**

Gasohol .....	238
Gear Position Indicator .....	55

**H**

Hazard Switch .....	98
Headlight Aim .....	176
Headlight Dimmer Switch .....	98
Helmet Holder .....	125

**HESD (Honda Electronic Steering**

Damper) .....	55, 199, 228
High beam indicator .....	27, 28, 29, 30, 31
High Coolant Temperature Indicator .....	55, 197
Honda Smart Key Indicator .....	95, 201
Horn Button .....	98

**I****Ignition Cut-off System**

Banking Sensor .....	228
Side Stand .....	167
Ignition Switch .....	99, 115, 227
Image Labels .....	7



## Indicator

ABS (Anti-lock Brake System) .....	94, 199
ABS Mode .....	55
Gear Position.....	55
HESD (Honda Electronic Steering Damper).....	55, 199
High Coolant Temperature .....	55, 197
Honda SMART Key .....	95, 201
Left Turn Signal .....	93
Low Oil Pressure .....	55, 198
Neutral.....	95
PGM-FI (Programmed Fuel Injection) Malfunction.....	94, 198
Quick Shifter .....	56
Right Turn Signal.....	93
Shift Indicators .....	93, 96
Steering Lock .....	95
Torque Control.....	93, 200
Torque Control OFF .....	93
Warning .....	198
<b>Indicators</b> .....	93
<b>INFO Area</b> .....	35
<b>Instruments</b> .....	26

## L

### Label

Accessories and Loading Warning .....	10
Battery .....	8, 9
Colour.....	135
FUEL .....	12
Radiator Cap .....	10
Rear Cushion.....	11
Safety Reminder .....	12
Tyre Information & Drive Chain .....	11

<b>Labels</b> .....	7
---------------------	---

<b>Lap timer</b> .....	32, 57
------------------------	--------

<b>Left Turn Signal Indicator</b> .....	93
---	----

### Light

Bulb .....	219
------------	-----

<b>Lithium-Ion (Li-Ion) Battery</b> .....	5, 138
---	--------

<b>Load Limits</b> .....	21
--------------------------	----

<b>Loading Guidelines</b> .....	21
---------------------------------	----

<b>Low Oil Pressure Indicator</b> .....	55, 198
---	---------

- M**
- Maintenance**
- Fundamentals ..... 134
  - Importance ..... 128
  - Safety ..... 128
  - Schedule ..... 129
- Maximum Weight Limit** ..... 21
- Meter**
- Odometer ..... 227
  - Tachometer Red Zone ..... 27, 28, 29, 31
  - Tripmeter ..... 227
- Mode**
- Riding ..... 109
  - Setting ..... 62
- Modifications** ..... 20
- N**
- Neutral Indicator** ..... 95
- O**
- Odometer** ..... 227
- ÖHLINS Smart EC System** ..... 185
- Oil**
- Engine ..... 141, 157
- Overheating** ..... 197
- Owner's Manual** ..... 126, 227
- P**
- P Value** ..... 111
- Parking** ..... 17
- Parts Location** ..... 22
- PASSING/LAP Switch** ..... 98
- Petrol** ..... 124, 238
- PGM-FI (Programmed Fuel Injection)**
- Malfunction Indicator Lamp (MIL)**... 94, 198
- Photosensor** ..... 229
- Pop-up Information**
- Failure Information ..... 54
  - Helpful ..... 53
  - Maintenance ..... 53
  - Start Mode Information ..... 54
- Protective Apparel** ..... 13
- Q**
- Quick Shifter** ..... 118
- Quick Shifter indicator** ..... 56

<b>R</b>	
<b>Rear Seat</b> .....	154
<b>Rear Suspension</b> .....	182
<b>Recommended</b>	
Coolant.....	144
Fuel.....	124
Oil .....	141
<b>Refuelling</b> .....	124
<b>Removal</b>	
Battery .....	150
Clip .....	152
Front Seat .....	153
Rear Seat.....	154
Under Cowl.....	155
<b>Repair Kit</b> .....	209
<b>Reserve Fuel Mode</b> .....	49
<b>Riding Mode</b> .....	109
<b>Riding Precautions</b> .....	15
<b>Right Turn Signal Indicator</b> .....	93
<b>S</b>	
<b>S Mode</b> .....	111
<b>Safety Precautions</b> .....	13
<b>Serial Numbers</b> .....	237
<b>Service Diagnostic Recorders</b> .....	222
<b>Setting Mode</b> .....	62
<b>Shift Indicators</b> .....	93
<b>Shifting Gears</b> .....	117
<b>Side Stand</b> .....	167
<b>Side Stand Ignition Cut-off System</b> .....	167
<b>Specifications</b> .....	240
<b>Speedometer</b> .....	27, 28, 29, 30, 31
<b>SPORT Mode Display</b> .....	32
<b>Start Button</b> .....	100, 115
<b>Start Mode</b> .....	119
<b>Starting the Engine</b> .....	115
<b>STD mode display</b> .....	27
<b>Steering Lock</b> .....	102
<b>Steering Lock Indicator</b> .....	95
<b>Stopping Engine</b> .....	227
<b>Storage</b>	
Equipment.....	125
Owner's Manual.....	126
Tool Kit .....	126
<b>Storing</b> .....	234

<b>Suspension</b>	
Front.....	179
ÖHLINS Smart EC System .....	185
Rear.....	182
S Mode.....	111
<b>Switch</b>	
Brakelight.....	166
Engine Stop.....	100, 227
Hazard .....	98
Headlight Dimmer .....	98
Ignition.....	99
MODE Switch.....	100
PASSING/LAP .....	98
Sel Down Switch.....	100
Sel Left/Right Switch .....	100
Sel Up Switch.....	100
Turn Signal.....	98
<b>Switches</b> .....	98
<b>T</b>	
<b>T Value</b> .....	111
<b>Tachometer</b> .....	27, 28, 29, 31
<b>Tachometer Red Zone</b> .....	27, 28, 29, 31
<b>Throttle</b> .....	175
<b>Torque Control Indicator</b> .....	93
<b>Torque Control OFF Indicator</b> .....	93
<b>Transporting</b> .....	235
<b>Tripmeter</b> .....	227
<b>Troubleshooting</b> .....	195
<b>Turn Signal Switch</b> .....	98
<b>Tyres</b>	
Air Pressure .....	145
Puncture.....	209
Replacing .....	145, 209
<b>W</b>	
<b>W Value</b> .....	111
<b>Washing Your Motorcycle</b> .....	229
<b>Washing Limit</b> .....	21
<b>Wheels</b>	
Front Removal .....	210
Rear Removal.....	215

**HONDA**  
The Power of Dreams

32MKR800  
00X32-MKR-8000



00X32-MKR-8000

XXX.XXXX.XX.L  
PRINTED IN XXXXX