

OWNER'S MANUAL

 **HONDA**

SH125i/SH150i



SH125i/SH150i

EN

This manual should be considered a permanent part of the vehicle and should remain with the vehicle when it is resold.

This publication includes the latest production information available before printing. Honda Motor Co., Ltd. reserves the right to make changes at any time without notice and without incurring any obligation.

No part of this publication may be reproduced without written permission.

The vehicle pictured in this owner's manual may not match your actual vehicle.

Welcome

Congratulations on your purchase of a new Honda vehicle. Your selection of a Honda makes you part of a worldwide family of satisfied customers who appreciate Honda's reputation for building quality into every product.

To ensure your safety and riding pleasure:

- Read this owner's manual carefully.
- Follow all recommendations and procedures contained in this manual.
- Pay close attention to safety messages contained in this manual and on the vehicle.

- The following codes in this manual indicate each country.
- The illustrations here in are based on the SH150AD ED type.

Country Codes

Code

Country

SH125AD

ED, II ED, III ED,
IV ED, V ED

European direct sales

SH150AD

ED, II ED, III ED,
IV ED, V ED

European direct sales

*The specifications may vary with each locale.

A Few Words About Safety

Your safety, and the safety of others, is very important. Operating this vehicle safely is an important responsibility.

To help you make informed decisions about safety, we have provided operating procedures and other information on safety labels and in this manual. This information alerts you to potential hazards that could hurt you or others.

Of course, it is not practical or possible to warn you about all hazards associated with operating or maintaining a vehicle. You must use your own good judgement.

You will find important safety information in a variety of forms, including:

- Safety labels on the vehicle
- Safety Messages preceded by a safety alert symbol  and one of three signal words: DANGER, WARNING, or CAUTION.

These signal words mean:

DANGER

You **WILL** be **KILLED** or **SERIOUSLY HURT** if you don't follow instructions.

WARNING

You **CAN** be **KILLED** or **SERIOUSLY HURT** if you don't follow instructions.

CAUTION

You **CAN** be **HURT** if you don't follow instructions.

Other important information is provided under the following titles:

NOTICE

Information to help you avoid damage to your vehicle, other property, or the environment.

Contents

Vehicle Safety P. 2

Operation Guide P. 18

Maintenance P. 74

Troubleshooting P. 114

Information P. 138

Specifications P. 152

Index P. 155

Vehicle Safety

This section contains important information for safe riding of your vehicle.
Please read this section carefully.

| | |
|--|-------|
| Safety Guidelines | P. 3 |
| Image Labels | P. 6 |
| Safety Precautions | P. 10 |
| Riding Precautions | P. 11 |
| Accessories & Modifications | P. 16 |
| Loading | P. 17 |

Safety Guidelines

Follow these guidelines to enhance your safety:

- Perform all routine and regular inspections specified in this manual.
- Stop the engine and keep sparks and flame away before filling the fuel tank.
- Do not run the engine in enclosed or partly enclosed areas. Carbon monoxide in exhaust gases is toxic and can kill you.

Always Wear a Helmet

It's a proven fact: helmets and protective apparel significantly reduce the number and severity of head and other injuries. So always wear an approved helmet and protective apparel. 📖 P. 10

Before Riding

Make sure that you are physically fit, mentally focused and free of alcohol and drugs. Check

that you and your passenger are both wearing an approved helmet and protective apparel. Instruct your passenger on holding onto the grab rail or your waist, leaning with you in turns, and keeping their feet on the footpegs, even when the vehicle is stopped.

Take Time to Learn & Practice

Even if you have ridden other vehicles, practice riding in a safe area to become familiar with how this vehicle works and handles, and to become accustomed to the vehicle's size and weight.

Ride Defensively

Always pay attention to other vehicles around you, and do not assume that other drivers see you. Be prepared to stop quickly or perform an evasive maneuver.

Make Yourself Easy to See

Make yourself more visible, especially at night, by wearing bright reflective clothing, positioning yourself so other drivers can see you, signaling before turning or changing lanes, and using your horn when necessary.

Ride within Your Limits

Never ride beyond your personal abilities or faster than conditions warrant. Fatigue and inattention can impair your ability to use good judgement and ride safely.

Don't Drink and Ride

Alcohol and riding don't mix. Even one alcoholic drink can reduce your ability to respond to changing conditions, and your reaction time gets worse with every additional drink. Don't drink and ride, and don't let your friends drink and ride either.

Keep Your Honda in Safe Condition

It's important to keep your vehicle properly maintained and in safe riding condition. Inspect your vehicle before every ride and perform all recommended maintenance. Never exceed load limits (➔ P. 17), and do not modify your vehicle or install accessories that would make your vehicle unsafe (➔ P. 16).

If You are Involved in a Crash

Personal safety is your first priority. If you or anyone else has been injured, take time to assess the severity of the injuries and whether it is safe to continue riding. Call for emergency assistance if needed. Also follow applicable laws and regulations if another person or vehicle is involved in the crash.

If you decide to continue riding, first turn the ignition switch to the  (Off) position, and evaluate the condition of your vehicle. Inspect for fluid leaks, check the tightness of critical nuts and bolts, and check the handlebar, control levers, brakes, and wheels. Ride slowly and cautiously.

Your vehicle may have suffered damage that is not immediately apparent. Have your vehicle thoroughly checked at a qualified service facility as soon as possible.

Carbon Monoxide Hazard

Exhaust contains poisonous carbon monoxide, a colourless, odorless gas. Breathing carbon monoxide can cause loss of consciousness and may lead to death.

If you run the engine in confined or even partly enclosed area, the air you breathe could contain a dangerous amount of carbon monoxide.

Never run your vehicle inside a garage or other enclosure.

WARNING

Running the engine of your vehicle while in an enclosed or even partially enclosed area can cause a rapid build-up of toxic carbon monoxide gas.

Breathing this colourless, odorless gas can quickly cause unconsciousness and lead to death.

Only run your vehicle's engine when it is located in a well ventilated area outdoors.

Image Labels

The following pages describe the label meanings. Some labels warn you of potential hazards that could cause serious injury. Others provide important safety information. Read this information carefully and don't remove the labels.

If a label comes off or becomes hard to read, contact your dealer for a replacement.

There is a specific symbol on each label. The meanings of each symbol and label are as follows.



Read instructions contained in Owner's Manual carefully.



Read instructions contained in Shop Manual carefully. In the interest of safety, take the vehicle to be serviced only by your dealer.



DANGER (with RED background)

You WILL be KILLED or SERIOUSLY HURT if you don't follow instructions.

WARNING (with ORANGE background)

You CAN be KILLED or SERIOUSLY HURT if you don't follow instructions.

CAUTION (with YELLOW background)

You CAN be HURT if you don't follow instructions.

BATTERY LABEL DANGER

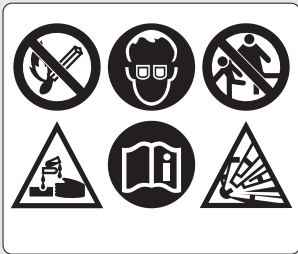

- Keep flame and spark away from the battery. Battery produce explosive gas that can cause explosion.
- Wear the eye protection and rubber gloves when handling the battery, or you can get burned or lose your eyesight by the battery electrolyte.
- Do not allow children and other people to touch a battery unless they understand proper handling and hazards of the battery very well.
- Handle the battery electrolyte with extreme care as it contains dilute sulfuric acid. Contact with your skin or eyes can burn you or cause loss of your eyesight.
- Read this manual carefully and understand it before handling the battery. Neglect of the instructions can cause personal injury and damage to the vehicle.
- Do not use a battery with the electrolyte at or below the lower level mark. It can explode causing serious injury.



RADIATOR CAP LABEL DANGER

NEVER OPEN WHEN HOT.

Hot coolant will scald you.

Relief pressure valve begins to open at **108 kPa**.

ACCESSORIES AND LOADING WARNING LABEL WARNING

ACCESSORIES AND LOADING

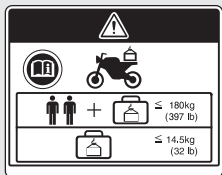

- The safety stability and handling of this vehicle may be affected by the addition of accessories and luggage.
- Read carefully the instructions contained in user's manual and installation guide before installing any accessory.
- The total weight of accessories and luggage added to rider's and passenger's weight should not exceed **180 kg (397 lb)**, which is the maximum weight capacity.
- The luggage weight must not exceed **14.5 kg (32 lb)** under any circumstances.
- The fitting of large fork-mounted or large handlebar mounted fairing is not recommended.

TYRE INFORMATION & CARGO LIMIT LABEL

For your protection, always wear helmet, protective apparel.

Cold tyre pressure:

[Driver only]

Front **200 kPa (2.00 kgf/cm², 29 psi)**

Rear **225 kPa (2.25 kgf/cm², 33 psi)**

[Driver and passenger]

Front **200 kPa (2.00 kgf/cm², 29 psi)**

Rear **225 kPa (2.25 kgf/cm², 33 psi)**

Cargo limit:

Shopping hook **1.5 kg (3.3 lb)**

Centre compartment **10 kg (22 lb)**

Rear carrier **3 kg (6.6 lb)**

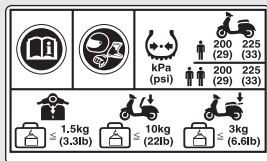
**FUEL LABEL**

Unleaded petrol only

ETHANOL up to 10 % by volume

Safety Precautions

- Ride cautiously and keep your hands on the handlebar and feet on the floor.
- Keep passenger's hands onto the grab rail or your waist, passenger's feet on the footpegs while riding.
- Always consider the safety of your passenger, as well as other drivers and riders.

Protective Apparel

Make sure that you and any passenger are wearing an approved helmet, eye protection, and high-visibility protective clothing. Ride defensively in response to weather and road conditions.

■ **Helmet**

Safety-standard certified, high-visibility, correct size for your head

- Must fit comfortably but securely, with the chin strap fastened.

- Face shield with unobstructed field of vision or other approved eye protection

⚠ WARNING

Not wearing a helmet increases the chance of serious injury or death in a crash.

Make sure that you and any passenger always wear an approved helmet and protective apparel.

■ **Gloves**

Full-finger leather gloves with high abrasion resistance

■ **Boots or Riding Shoes**

Sturdy boots with non-slip soles and ankle protection

■ **Jacket and Trousers**

Protective, highly visible, long-sleeved jacket and durable trousers for riding (or a protective suit)

Riding Precautions

Running-in Period

During the first 500 km (300 miles) of running, follow these guidelines to ensure your vehicle's future reliability and performance.

- Avoid full-throttle starts and rapid acceleration.
- Avoid hard braking.
- Ride conservatively.

Brakes

Observe the following guidelines:

- Avoid excessively hard braking.
 - ▶ Sudden braking can reduce the vehicle's stability.
 - ▶ Where possible, reduce speed before turning; otherwise you risk sliding out.

- Exercise caution on low traction surfaces.
 - ▶ The tyres slip more easily on such surfaces and braking distances are longer.
- Avoid continuous braking.
 - ▶ Repeated braking, such as when descending long, steep slopes can seriously overheat the brakes, reducing their effectiveness.
- For full braking effectiveness, operate both the front and rear brakes together.

■ Anti-lock Brake System (ABS)

This model is equipped with an Anti-lock Brake System (ABS) designed to help prevent the brakes from locking up during hard braking.

- ABS does not reduce braking distance. In certain circumstances, ABS may result in a longer stopping distance.
- ABS does not function at speeds below 10 km/h (6 mph).
- The brake levers may recoil slightly when applying the brakes. This is normal.
- Always use the recommended front/rear tyres to ensure correct ABS operation.

■ Wet or Rainy Conditions

Road surfaces are slippery when wet, and wet brakes further reduce braking efficiency. Exercise extra caution when braking in wet conditions.

If the brakes get wet, apply the brakes while riding at low speed to help them dry.

Parking

- Park on a firm, level surface.
- If you must park on a slight incline or loose surface, park so that the vehicle cannot move or fall over.
- Make sure that high-temperature parts cannot come into contact with flammable materials.
- Do not touch the engine, muffler, brakes and other high-temperature parts until they cool down.
- To reduce the likelihood of theft, always lock the handlebar, lock the ignition switch (➡ P. 51) and leave your vehicle while taking the Honda SMART Key with you. Deactivate the Honda SMART Key system if necessary.
➡ P. 46
Use of an anti-theft device is also recommended.

■ Parking with the Side Stand or Centre Stand

1. Stop the engine.

2. Using the side stand

Push the side stand down.

Slowly lean the vehicle to the left until its weight rests on the side stand.

Using the centre stand

To lower the centre stand, stand on the left side of the vehicle.

Hold the left handle grip and the grab rail. Press down on the tip of the centre stand with your right foot and, simultaneously, pull up and back.

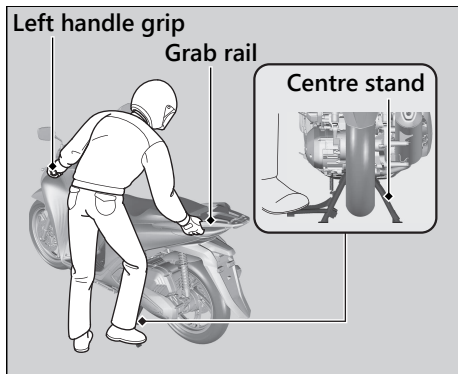

3. Turn the handlebar fully to the left.
 - ▶ Turning the handlebar to the right reduces stability and may cause the vehicle to fall.
4. Turn the ignition switch to the  (Lock) position (➔ P. 44) and lock the ignition switch (➔ P. 51).

Refuelling and Fuel Guidelines

Follow these guidelines to protect the engine, fuel system and catalytic converter:

- Use only unleaded petrol.
- Use recommended octane number. Using lower octane petrol will result in decreased engine performance.
- Do not use fuels containing a high concentration of alcohol. ➤ P. 150
- Do not use stale or contaminated petrol or an oil/petrol mixture.
- Avoid getting dirt or water in the fuel tank.

Honda selectable torque control

When the Honda selectable torque control (Torque Control) detects rear wheel spin during acceleration, the system will limit the amount of torque applied to the rear wheel.

Torque Control does not work during deceleration and will not prevent the rear wheel from skidding due to engine braking. Do not close the throttle suddenly, especially when riding on slippery surfaces.

Torque Control may not compensate for rough road conditions or rapid throttle operation. Always consider road and weather conditions, as well as your skills and condition, when applying throttle.

If your vehicle gets stuck in mud, snow or sand, it may be easier to free it by turning off the Torque Control temporarily.

Temporarily turning off Torque Control also may help you maintain control and balance when riding on off-road terrain.

Always use the recommended tyres and the Honda Genuine Parts for drive system such as the drive belt and weight rollers, to ensure correct Torque Control operation.

Accessories & Modifications

We strongly advise that you do not add any accessories that were not specifically designed for your vehicle by Honda or make modifications to your vehicle from its original design. Doing so can make it unsafe. Modifying your vehicle may also void your warranty and make your vehicle illegal to operate on public roads. Before deciding to install accessories on your vehicle be certain the modification is safe and legal.

WARNING

Improper accessories or modifications can cause a crash in which you can be seriously hurt or killed.

Follow all instructions in this owner's manual regarding accessories and modifications.

Do not pull a trailer with, or attach a sidecar to, your vehicle. Your vehicle was not designed for these attachments, and their use can seriously impair your vehicle's handling.

Loading

- Carrying extra weight affects your vehicle's handling, braking and stability. Always ride at a safe speed for the load you are carrying.
- Avoid carrying an excessive load and keep within specified load limits.
Maximum weight capacity / Maximum luggage weight ➤ P. 152
- Tie all luggage securely, evenly balanced and close to the centre of the vehicle.
- Do not place objects near the lights or the muffler.

WARNING

Overloading or improper loading can cause a crash and you can be seriously hurt or killed.

Follow all load limits and other loading guidelines in this manual.





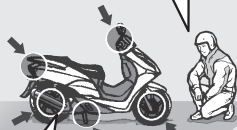

Basic Operation Flow

Pre-ride Inspection P.79

Carefully inspect your vehicle to make sure that it is safe to ride.



How to use basic features.

- Instruments  P.22
- Indicators  P.40
- Switches  P.42
- Steering Lock  P.44
- Answer Back System  P.53
- Honda SMART Key System  P.45
- Idling Stop System  P.55

Acceleration P.62

Apply throttle gradually.
Obey the speed limit.



Starting the Engine P.59

Start and warm the engine.
Avoid revving the engine.



Starting the Vehicle P.62

Before pulling away, indicate your direction with the turn signal switch, and check for oncoming traffic.



Braking → P.63

STOP!



Close the throttle and apply the front and rear brakes together.
 ▶ The brakelight will indicate that you have applied the brakes.

Parking → P.12

Park on a firm level surface.
 Use the stand, lock the steering.



Stopping

If pulling off the road, signal early enough to show traffic that you are pulling over, and pull over smoothly.



Turning Corners

Do your braking before entering corners.



Gradually reapply throttle when exiting turn.

Refuelling → P.64

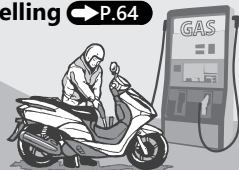

Parts Location

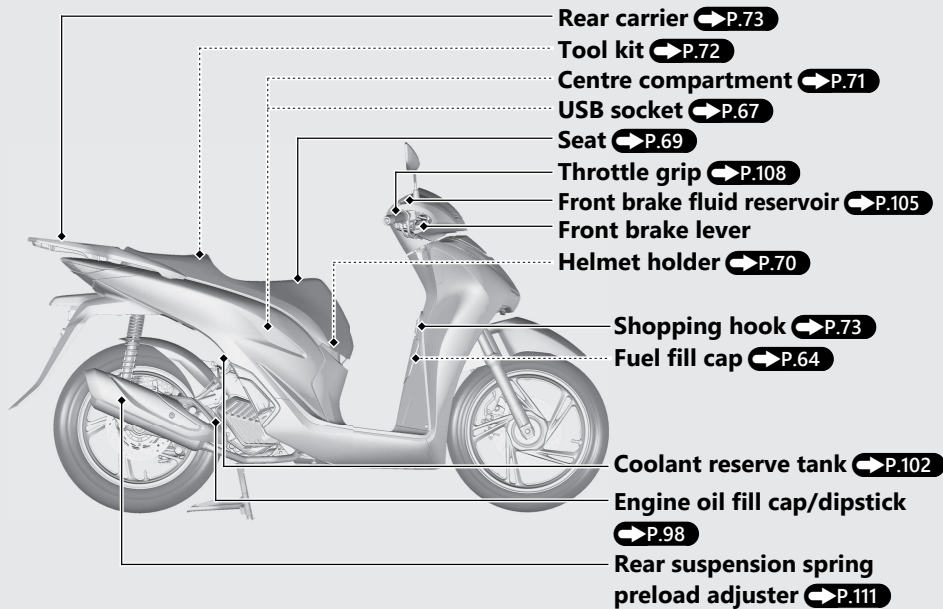

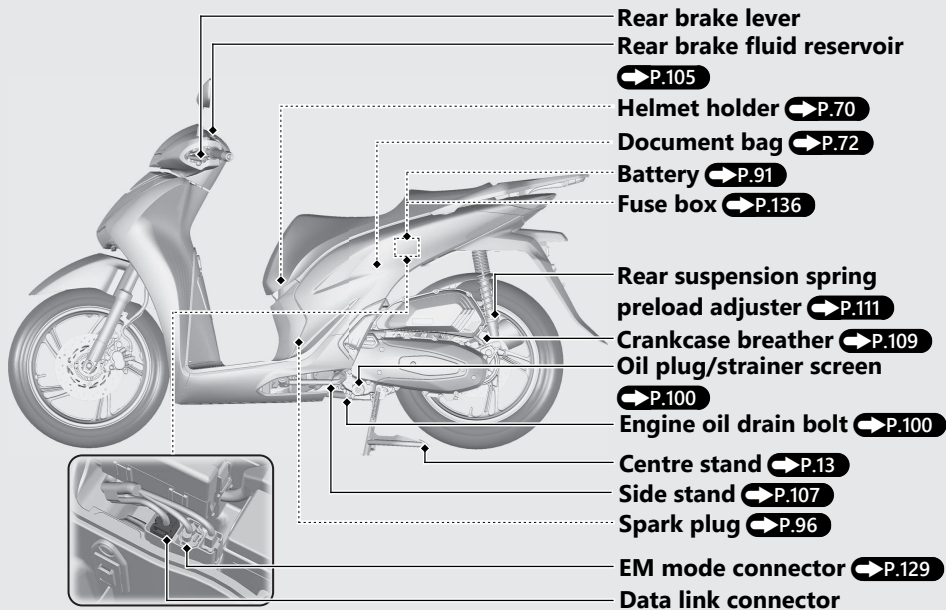

Instruments

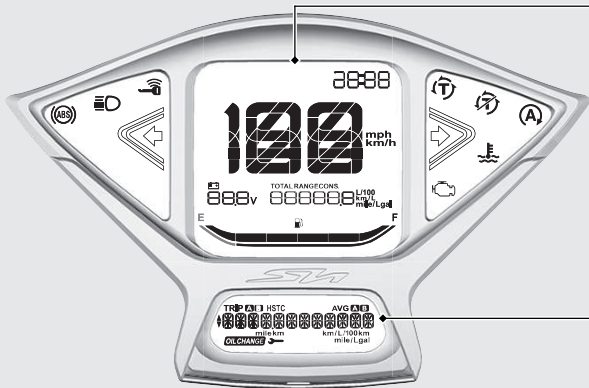
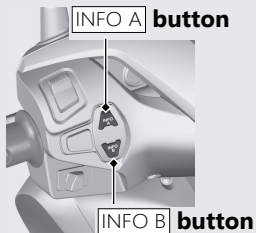

Display Check

When the ignition switch is turned to the **I** (On) position, initial animation will show. If any part of these displays does not come on when it should, have your dealer check for problems.

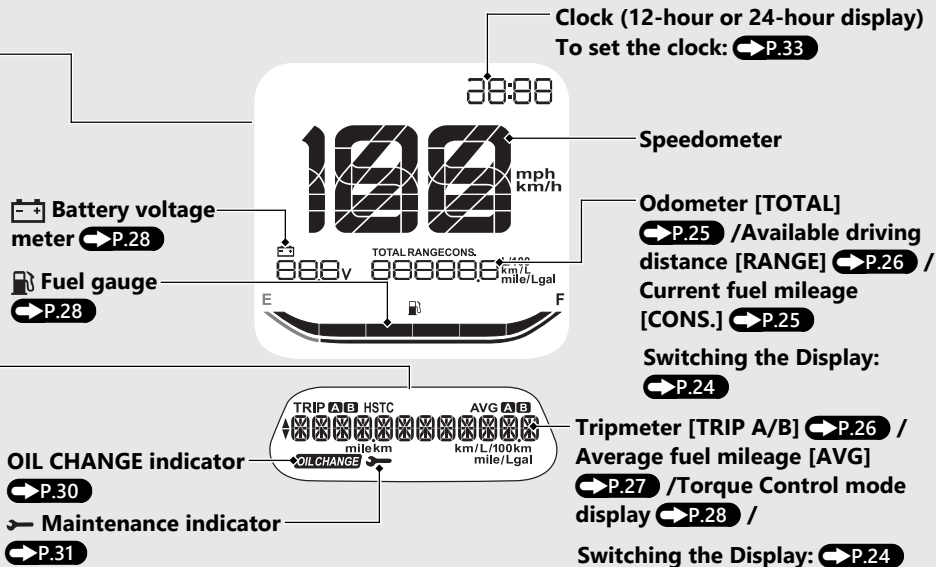

Instruments *(Continued)*

Switching the Display

The **INFO A** button switches between the odometer, available driving distance and current fuel mileage.

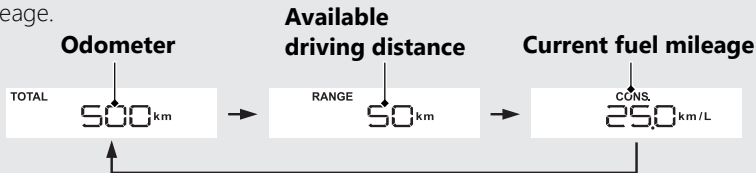

➔ Press the **INFO A** button

The **INFO B** button switches between the tripmeter A, tripmeter B, and Torque Control mode display. Also **INFO B** button switches between the average fuel mileage.

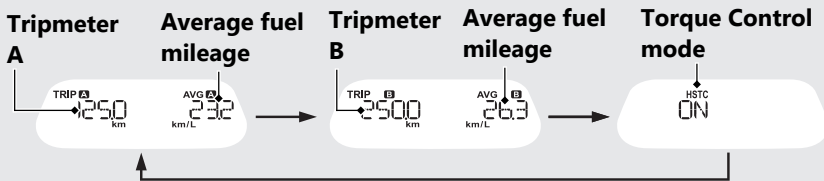

➔ Press the **INFO B** button

Odometer

Total distance ridden.

When "-----" is displayed, go to your dealer for service.

Current fuel mileage

Displays the current or instant fuel mileage.

- When your speed is less than about 7 km/h (4 mph): "--.-" is displayed.
- When selecting the "L/100km", "km/L" or "mile/L".

Display range: 0.0 to 99.9 km/L (L/100km or mile/L).

If the calculated value is 99.9 km/L (L/100km or mile/L) or more: "99.9 km/L (L/100km or mile/L)" is displayed.

If the calculated value is less than 0.1 km/L (L/100km or mile/L): "0.0 km/L (L/100km or mile/L)" is displayed.

- When selecting the "mile/gal".

Display range: 0.0 to 199.9 mile/gal.

If the calculated value is 199.9 mile/gal or more: "199.9 mile/gal" is displayed.

If the calculated value is less than 0.1 mile/gal: "0.0 mile/gal" is displayed.

When "--.-" is displayed except for the above mentioned cases, go to your dealer for service.

Instruments *(Continued)*

Available driving distance

Displays the estimated distance you can travel on the remaining fuel.

Display range: 999 to 0 km (mile)

- If the calculated value is 999 km (mile) or more: "999 km (mile)" is displayed.
- Initial display: "---" is displayed.
- When the amount of remaining fuel is below 1.0 L (0.26 US gal, 0.22 Imp gal): "---" is displayed.

The indicated available driving distance is calculated based on the driving conditions, and the indicated figure may not always be the actual available distance.

When "---" is displayed except for the above mentioned cases, go to your dealer for service.

Tripmeter A/B

Distance ridden since tripmeter A or tripmeter B respectively were reset.

When "----.-" is displayed, go to your dealer for service.

To reset the tripmeter:  **P.29**

Average fuel mileage

Displays the average fuel mileage since the selected tripmeter was reset.

The average fuel mileage will be calculated based on value displayed on the tripmeter (A or B) selected.

- When the tripmeter A or B is reset: "--.-" is displayed.
- When selecting the "L/100km", "km/L" or "mile/L".

Display range: 0.0 to 99.9 km/L (L/100km or mile/L).

If the calculated value is 99.9 km/L (L/100km or mile/L) or more: "99.9 km/L (L/100km or mile/L)" is displayed.

If the calculated value is less than 0.1 km/L: "0.0 km/L" is displayed.

- When selecting the "mile/gal".

Display range: 0.0 to 199.9 mile/gal.

If the calculated value is 199.9 mile/gal or more: "199.9 mile/gal" is displayed.

If the calculated value is less than 0.1 mile/gal: "0.0 mile/gal" is displayed.

When "--.-" is displayed except for the above mentioned cases, go to your dealer for service.

To reset the average fuel mileage:



Instruments *(Continued)*

Torque Control mode

Displays the current Torque Control setting.

Honda selectable torque control

➡ P.58

Battery voltage meter

Displays the current voltage.

Fuel gauge

Remaining fuel when there is only 1st (E) segment: approximately 1.6 L (0.42 US gal, 0.35 Imp gal).

This segment flashes when the fuel decreases further.



NOTICE

You should refuel when the reading approaches the E (1st) segment. Running out of fuel can cause the engine to misfire, damaging the catalytic converter.

If the fuel gauge indicator flashes in a repeat pattern or turns off: ➡ P.121

To reset the tripmeter and average fuel mileage

To reset tripmeter A and average fuel mileage (this is based on tripmeter A) together, press and hold the **INFO B** button while tripmeter A is displayed.

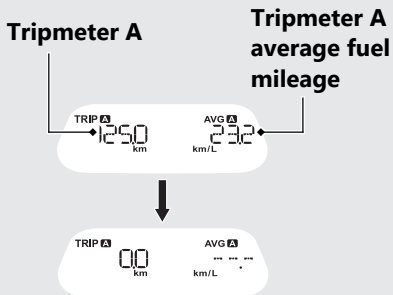

To reset tripmeter B and average fuel mileage (this is based on tripmeter B) together, press and hold the **INFO B** button while tripmeter B is displayed.

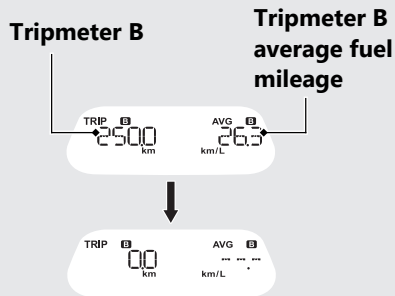

Instruments *(Continued)*

OIL CHANGE indicator

The indicator is turned on whenever the running distance reaches the programmed oil change interval.

When the OIL CHANGE indicator is appeared, reset the indicator after changing the engine oil. **➡ P.99**

- ▶ The OIL CHANGE indicator is appeared for the first time when the running distance reaches 1,000 km (600 miles).
- ▶ The OIL CHANGE indicator is appeared when the running distance reaches every 6,000 km (4,000 miles) after the first indication was reset.
- ▶ The indicator does not go off until it is reset.

OIL CHANGE indicator



If the oil is changed before the oil change indicator comes on, be sure to reset the OIL CHANGE indicator after changing the oil.

To reset the OIL CHANGE indicator

➡ P.33

You can also check the remaining distance to next interval of the oil change.

To check the remaining distance

➡ P.32

Maintenance indicator

The indicator is turned on whenever the running distance reaches the programmed maintenance interval.

When the maintenance indicator is appeared, reset the indicator after performing the periodic maintenance. **➔P.75**

- ▶ The maintenance indicator is appeared for the first time when the running distance reaches 1,000 km (600 miles).
- ▶ The maintenance indicator is appeared when the running distance reaches every 6,000 km (4,000 miles) after first indication was reset.
- ▶ The indicator does not go off until it is reset.



If the periodic maintenance is performed before the maintenance indicator comes on, be sure to reset the maintenance indicator after performing the periodic maintenance.

To reset the maintenance indicator

➔P.33

You can also check the remaining distance to next interval of the maintenance.

To check the remaining distance

➔P.32

Instruments *(Continued)*

To check the remaining distance

You can check the remaining distance to next interval of the oil change and maintenance.

Press the **INFO A** button and **INFO B** button, each remaining distance appears briefly.

**Remaining oil
change distance**



**Remaining
maintenance
distance**



Display Setting

Following items to change or reset sequentially.

- Time format setting
- Clock setting
- Backlight brightness adjustment
- Changing of mileage unit
- Changing of fuel mileage meter unit
- OIL CHANGE indicator reset mode
- Maintenance indicator reset mode

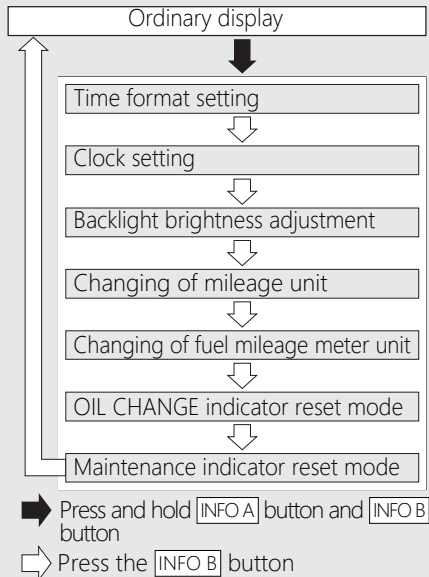

Instruments *(Continued)*



If the ignition switch is turned to the  (Off) position or the button is not pressed for about 30 seconds, the control is automatically switched from the setting mode to the ordinary display.

If the button is not pressed for about 30 seconds items in the process of being set will be discarded and only items where settings have been finalized will be applied.

Only if the ignition switch is turned to the  (Off) position will items in the process of being set and those that are finalized be applied.

1 Time format setting:

You can switch the time format between 12 hour format or 24 hour format.

- 1 Turn the ignition switch to the  (On) position.
- 2 Press and hold  button and  button, the current time format start flashing.



- 3 Press the  button to select "12 hr" or "24 hr".



- 4 Press the  button. The time format is set, and then the display moves to the clock setting.

2 Clock setting:

- 1 Press the **INFO A** button until the desired hour is displayed.
 - ▶ Press and hold the **INFO A** button to advance the hour fast.

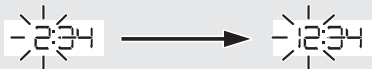

- 2 Press the **INFO B** button. The minute digits start flashing.



- 3 Press the **INFO A** button until the desired minute is displayed.
 - ▶ Press and hold the **INFO A** button to advance the minute fast.

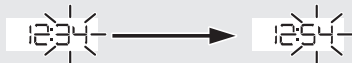

- 4 Press the **INFO B** button. The clock is set, and then the display moves to the backlight brightness adjustment.

Instruments *(Continued)*

3 Backlight brightness adjustment:

You can adjust the brightness to one of five levels.

- 1 Press the **INFO A** button. The brightness is switched.
- 2 Press the **INFO B** button. The backlight is set, and then the display moves to the changing of speed and mileage unit.

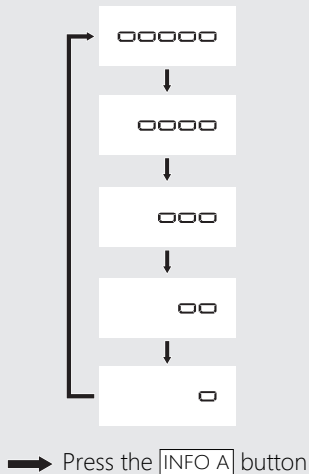

4 Changing of speed and mileage unit:

- 1 Press the **INFO A** button to select either "km/h" and "km" or "mph" and "mile".

When selecting the "mph" & "mile".

- Fuel mileage meter unit shows "mile/gal" or "mile/L".

When selecting the "km/h" & "km".

- Fuel mileage meter unit shows "km/L" or "L/100km".

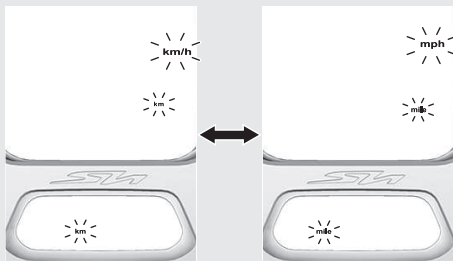

- 2 Press the **INFO B** button. The speed and mileage unit is set, and then the display moves to the changing of fuel mileage meter unit.

5 Changing of fuel mileage meter unit:

- 1 Press the **INFO A** button to select either "L/100km" or "km/L".

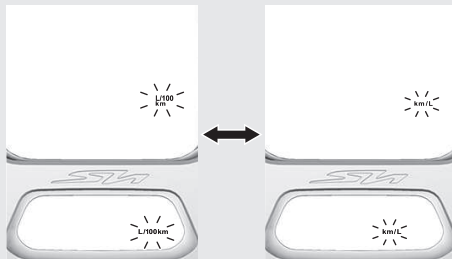

Instruments (Continued)

If the "mph" for speed and "mile" for mileage are selected, the fuel mileage shown by "mile/gal" or "mile/L".

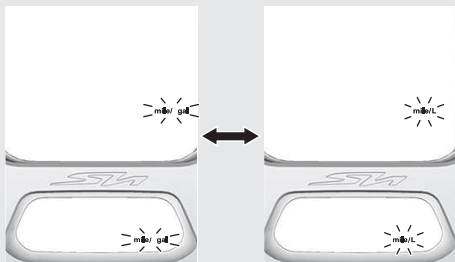

- Press the **INFO B** button. The fuel mileage meter unit is set, and then the display moves to the OIL CHANGE indicator reset mode.

6 OIL CHANGE indicator reset mode

Press and hold the **INFO A** button. The OIL CHANGE indicator and remaining distance are reset, then the maintenance indicator and remaining distance start flashing after next interval of the oil change is appeared briefly.

- If the OIL CHANGE indicator and remaining distance are not to be reset, press the **INFO B** button.



7 Maintenance indicator reset mode

Press and hold the **INFO A** button.

The maintenance indicator and remaining distance are reset, then the display will return to the ordinary display after next interval of the maintenance is appeared briefly.

- ▶ If the maintenance indicator and remaining distance are not to be reset, press the **INFO B** button.



Indicators

If one of these indicators does not come on when it should, have your dealer check for problems.

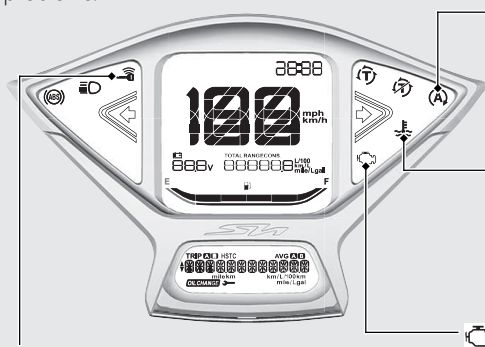

Honda SMART Key indicator

- Comes on when vehicle and Honda SMART Key verification is complete, and the ignition switch can be operated.
- Goes off when the ignition switch is turned to the **I** (On) position.

When the Honda SMART Key Indicator

Flashes:  **P.120**

(A) Idling Stop indicator

Comes on briefly when the Idling Stop switch in the IDLING STOP with the ignition switch turned to the **I** (On) position.

Idling Stop system:  **P.55**

High coolant temperature indicator

Comes on when the coolant temperature exceeds the specified value.

If it comes on while riding:  **P.116**

PGM-FI (Programmed Fuel Injection) malfunction indicator lamp (MIL)

Comes on briefly when the ignition switch is turned to the **I** (On) position.

If it comes on while engine is running:

 **P.117**

ABS (Anti-lock Brake System) indicator

- Comes on when the ignition switch is turned to the **I** (On) position.
- Goes off when your speed reaches approximately 10 km/h (6 mph).

If it comes on while riding:  **P.118**

High beam indicator

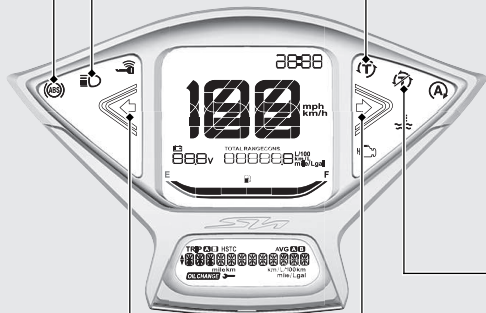

 **Left turn signal indicator**

 **Right turn signal indicator**

Torque Control indicator

- Comes on when the ignition switch is turned to the **I** (On) position.
- Goes off when your speed reaches approximately 3 km/h (2 mph) to indicate Torque Control is ready to work.
- Blinks when Torque Control is operating.

If it comes on while riding:  **P.119**

Torque Control OFF indicator

Comes on when the Torque Control is turned to off.

Switches

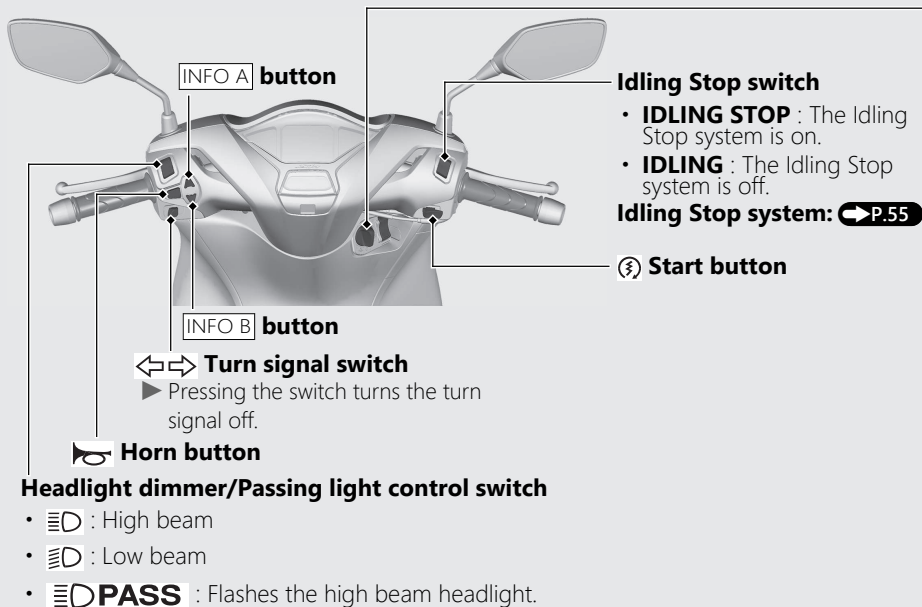

Ignition switch

Switches the electrical system on/off, locks the steering and operates the fuel lid and seat opener switch.

To unlock the ignition switch:

 P.50

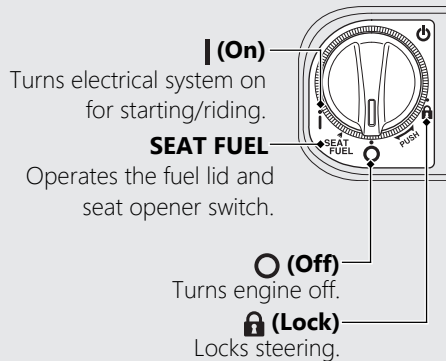

Switches *(Continued)*



Steering Lock

Lock the steering when parking to help prevent theft.

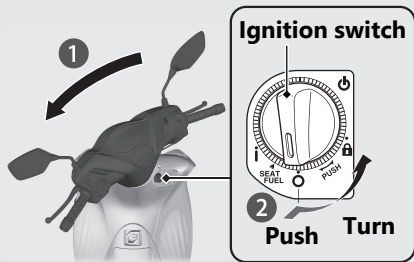
A U-shaped wheel lock or similar device is also recommended.





Locking

- 1 Turn the handlebar all the way to the left.
- 2 Push the ignition switch down, and turn it to the  (Lock) position.
 - ▶ To unlock the ignition switch  **P.50**
 - ▶ Jiggle the handlebar if the lock is difficult to engage.
- 3 Lock the ignition switch.  **P.51**

Unlocking

Push the ignition switch in, and turn it to the

 (Off) position.

- ▶ To unlock the ignition switch  **P.50**

Honda SMART Key System

The Honda SMART Key system allows you to operate the main switch without inserting a key into a keyhole.

The system runs a two-way authentication between the vehicle and the Honda SMART Key to verify if it is the registered Honda SMART Key.

The Honda SMART Key system uses low-intensity radio waves. It may affect medical equipment such as a cardiac pacemakers.

Honda SMART Key System *(Continued)*

Switching the Honda SMART Key System

To switch the Honda SMART Key system to activation or deactivation

Press the ON/OFF button until the LED colour of the Honda SMART Key changes.

To check the Honda SMART Key system status

Lightly press the ON/OFF button. The LED of the Honda SMART Key will show the status.

When the LED of the Honda SMART Key is:

Green: Honda SMART Key system authentication can be performed.
(activation)

Red: Honda SMART Key system authentication can not be performed.
(deactivation)

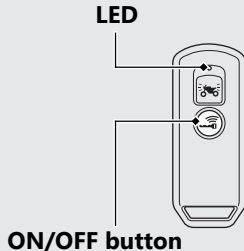

Operating Range

The operating range varies when the ignition switch is locked or unlocked.

The Honda SMART Key system uses low-intensity radio waves. Therefore the operating range may become wider or narrower, or the Honda SMART Key system may not work properly in the following environments.

- When the Honda SMART Key battery is depleted.
- When there are facilities nearby that generate strong radio waves or noise such as TV towers, power stations, radio stations, or airports.
- When you carry the Honda SMART Key with a laptop or wireless communication device such as a radio or mobile phone.
- When the Honda SMART Key comes into contact with or is covered by metal objects.

When the ignition switch is unlocked:

The system can be operated within the shaded area shown in the illustration.

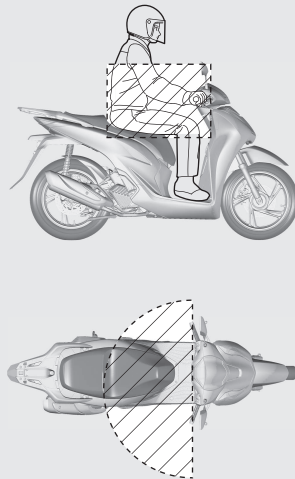

Honda SMART Key System *(Continued)*

When the ignition switch is locked:

The system can be operated within the shaded area shown in the illustration.

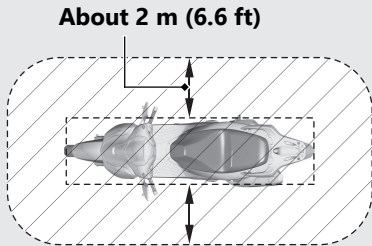

Anyone can unlock the ignition switch and start the engine if your Honda SMART Key is within operating range of your vehicle, even if you are on the other side of a wall or window. If you are away from your vehicle but your Honda SMART Key is still within operating range, deactivate the Honda SMART Key system.

To switching the Honda SMART Key system P.46

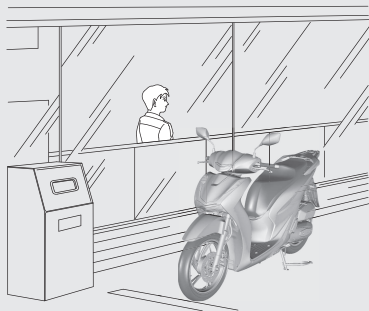

Anyone in possession of the Honda SMART Key can perform the following operations if the Honda SMART Key is within operating range:

- Starting the engine
- Unlocking the ignition switch
- Releasing the seat lock
- Opening the fuel lid
- Unlocking the steering lock

You should always keep the Honda SMART Key on your person after you get on and off the vehicle or while riding.

Do not place the Honda SMART Key in the centre compartment.

If the ignition switch is in the **I** (On) position, the vehicle can be operated even by a person who does not have a verified Honda SMART Key.

Whenever you leave your vehicle, lock the steering and lock the ignition switch.

 **P.51**

Make sure the ignition switch ring goes off and all turn signals flash once at this time.

Honda SMART Key System *(Continued)*

Switching the ignition switch

To Unlock the Ignition Switch



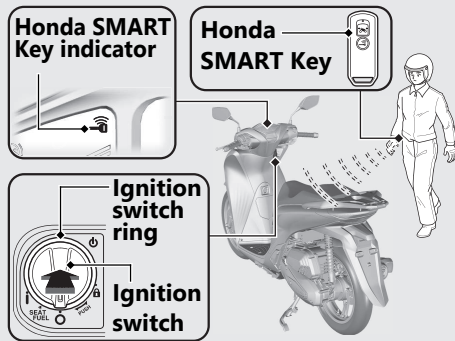

- 1 Make sure that the Honda SMART Key system is activated. **➔P.46**
- 2 To authenticate the Honda SMART Key system, push the ignition switch.
 - ▶ When properly authenticated, the ignition switch is unlocked, and the Honda SMART Key indicator and ignition switch ring come on.
- 3 Turn the ignition switch to the **I** (On) position while the Honda SMART Key indicator comes on.
 - ▶ If you do not turn the ignition switch to the **I** (On) position within 20 seconds after pushing in the ignition switch in, the Honda SMART Key indicator and ignition switch ring will go off, the turn signals flash 1 time, and then the ignition switch will be locked.

When the Honda SMART Key system does not work properly **➔P.125**

If someone without the Honda SMART Key tries to turn the ignition switch, the ignition switch rotates freely. If you notice the ignition switch is in a different position, turn the ignition switch to the original position (O (Off) or **I** (Lock)).



To Lock the Ignition Switch

- Turn the ignition switch to the SEAT FUEL, ○ (Off) or  (Lock) position.
- Lock the ignition switch by doing one of the following:
 - Leave the operating range with the Honda SMART Key.  **P.47**
 - Push the ignition switch.
 - Wait for approximately 20 seconds after turning the ignition switch from | (On) to SEAT FUEL, ○ (Off) or  (Lock) position.
 - Switch the Honda SMART Key system to deactivation.  **P.46**
- Make sure that the Honda SMART Key indicator and ignition switch ring go off and the turn signals flash once. This indicates that the ignition switch is locked.

When the Honda SMART Key system does not work properly  **P.125**

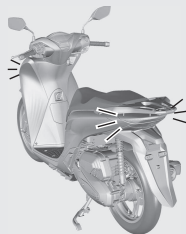
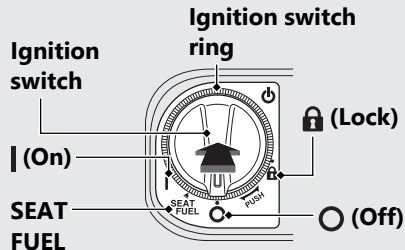



Honda SMART Key System *(Continued)*

Always make sure the ignition switch position is in the ○ (Off) or 🔒 (Lock) position when you leave your vehicle.

When the ignition switch is locked in the SEAT FUEL position, the ignition switch can be turned ○ (Off) only once.

When the ignition switch is locked in the ○ (Off) position, the steering cannot be locked. To lock the steering, unlock the ignition switch.

Answer Back System

The answer back system is a device to find the location of your vehicle and to inform you that the immobilizer function of the Honda SMART key system is activated. When you press the answer back button on the Honda SMART Key with the ignition switch  (Off) or  (Lock) position, the turn signals blink, and the ignition switch ring lights, informing you of your vehicle's location and activation of the immobilizer function. The ignition switch ring will light for about 1 minute.

The answer back system uses low-intensity radio waves. It may affect medical equipment such as a cardiac pacemaker.

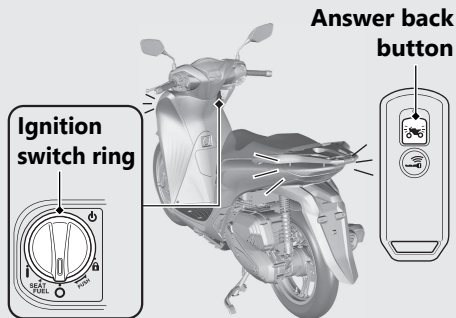

Answer Back System *(Continued)*

Operation

Press the answer back button on the Honda SMART Key.

- ▶ The answer back system will not function when the ignition switch is in the **I** (On) position.

If the ignition switch is left the **O** (Off) or **L** (Lock) position for more than 10 days, the answer back system will no longer operate.

During the system is activating, when the vehicle receives a signal by pressing the answer back button, the system activation will be extended for 10 days.

To reset the system, unlock the ignition switch and turn the ignition switch to the **I** (On) position once.

- ▶ To unlock the ignition switch. **➡ P.50**

NOTICE

When the battery in the vehicle is weak, the answer back system may not function.

Idling Stop System

Idling Stop system is designed to help reduce the fuel consumption and noise, by idling stop while making a stop such as waiting at an intersection.

Switching the Idling Stop System On or Off

Switches the Idling Stop system on or off using the Idling Stop switch.

- ON: **IDLING STOP**
 - ▶ Idling Stop indicator comes on when the Idling Stop system becomes ready to stop the engine while riding. Idling Stop indicator flashes when the engine is stopped by the Idling Stop system.
- OFF: **IDLING**
 - ▶ Idling Stop indicator does not come on when the Idling Stop system is off.

Activation of the Idling Stop System

The Idling Stop system becomes ready to stop the engine and Idling Stop indicator comes on when the following requirements are satisfied with the Idling Stop switch in the IDLING STOP position:

- start the engine by pressing the start button
- warm up the engine enough
- ride the vehicle at speeds over 10 km/h (6 mph)

Idling Stop Indicator Does Not Come

On:  **P.122**

Idling Stop switch

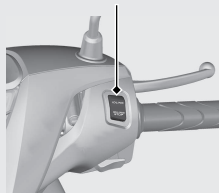

Idling Stop indicator



Idling Stop System *(Continued)*

Stopping the engine by the Idling Stop System

The engine stops and Idling Stop indicator changes to flash after you close the throttle completely and stop the vehicle while the Idling Stop indicator is on.

- ▶ While the engine is stopped by the Idling Stop system, if you press the Idling Stop switch to IDLING, the Idling Stop system will be cancelled. The engine will not restart even when you open the throttle.

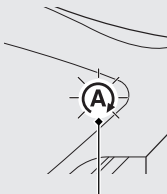

Idling Stop indicator

Safety Precaution for the Idling Stop System

Do not go away from the vehicle while the Idling Stop indicator is flashing. When you go away from the vehicle, always turn the ignition switch to the  (Off) position.

- ▶ The engine may start unexpectedly if the throttle is opened.

Engine is Not Stopped by the Idling Stop System While the Idling Stop Indicator is On:

NOTICE

Stopping by the Idling Stop system for a long time may cause battery discharge.

Restarting the Engine

Check that the Idling Stop indicator is flashing, and then open the throttle.

- ▶ If it is not flashing, you can't restart the engine with the Idling Stop system, even if you open the throttle.
- ▶ While the engine is stopped by the Idling Stop system, if you operate the side stand, the flashing Idling Stop indicator turns off or stops flashing and stays on, then the engine will not restart even when you open the throttle.

Engine Does Not Start Even If the Throttle is Opened:  **P.124**

NOTICE

Headlight stays on after the engine is stopped by the Idling Stop system. The battery may discharge and you may not be able to restart engine.

When the battery is weak, switch the Idling Stop switch to IDLING and do not to use the Idling Stop system. See your dealer to check the battery.

See your dealer for checking the battery as specified in the maintenance schedule.

Maintenance Schedule:  **P.76**

Honda selectable torque control

Torque Control (engine power control) can be turned on/off.

- ▶ Do not operate the Torque Control switch while riding.
Stop the vehicle first, turn the Torque Control off or on.
- ▶ The Torque Control cannot be turned off when the system is activated (Torque Control indicator blinking).
- ▶ Each time the ignition switch is turned to the (On) position, the Torque Control will automatically be set to on .

- ▶ If the Torque Control is disabled (Off), "HSTC OFF" is displayed and the Torque Control OFF indicator comes on.

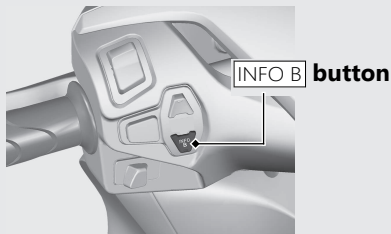

Torque Control on and off

1. Select the Torque Control mode.

➔ P.24

2. Torque Control can be turned on and off by pressing and holding the INFO B button.
 - ▶ If the Torque Control is enabled (On), "HSTC ON" is displayed and the Torque Control OFF indicator goes off.

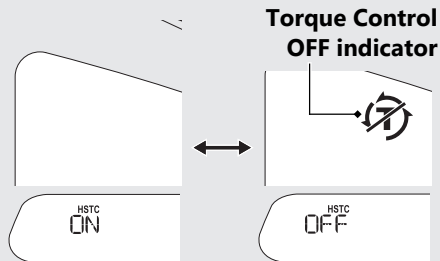

Starting the Engine

Start your engine using the following procedure, regardless of whether the engine is cold or warm.

This vehicle is equipped with a side stand ignition cut-off system.

- ▶ If the side stand is down, the engine cannot be started.
- ▶ If you lower the side stand with the engine running, it will automatically shut off.

This vehicle is equipped with a Honda SMART Key system. Always keep Honda SMART Key on you when you ride the vehicle. ➔ **P.47**

If the engine of this vehicle is stopped while the ignition switch is in the **I** (On) position, authentication will be disabled after a certain amount of time or if you leave the authentication range. Restart the engine by performing step **3** & **4** under the starting procedure.

- ▶ If the engine of this vehicle is stopped by the Idling Stop System, authentication will not be disabled.

NOTICE

- If the engine does not start within 5 seconds, turn the ignition switch to the **O** (Off) position and wait 10 seconds before trying to start the engine again to recover battery voltage.
- Extended fast idling and reving the engine can damage the engine, and the exhaust system.
- The engine will not start if the throttle is fully open.
- If the vehicle is over-turned, you must first turn the ignition switch to the **O** (Off) position and then inspect the vehicle carefully.

Starting the Engine (Continued)

- 1 Place the vehicle on its centre stand.
- 2 Turn the ignition switch to the **I** (On) position.
 - ▶ To unlock the ignition switch. **➡ P.50**

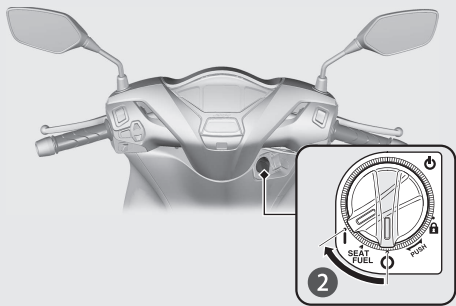

- 3 Squeeze the rear brake lever.
 - ▶ The starter motor will only work when the rear brake lever is squeezed and the side stand is up.
- 4 Press the start button with the throttle completely closed. Release the start button as soon as the engine starts.

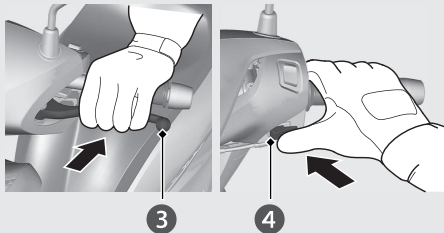

If you cannot start the engine:

- ① Place the vehicle on its centre stand and squeeze the rear brake lever.
- ② With the throttle slightly open (about 3 mm, without freeplay), press the start button.

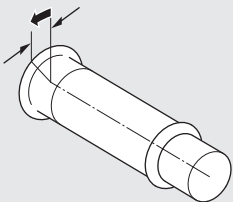
About 3 mm, without freeplay**If the engine does not start:**

- ① Open the throttle fully and press the start button for 5 seconds.
- ② Repeat the normal starting procedure.
- ③ If the engine starts, open the throttle slightly if idling is unstable.
- ④ If the engine does not start, wait 10 seconds before trying steps ① & ② again.

If Engine Will Not Start ➔ P.115

Riding

Starting the Vehicle

- 1 Push the vehicle forward off the centre stand.
 - ▶ Squeeze the rear brake lever.
 - ▶ Keep throttle closed.

Make sure the side stand and centre stand are up.

- 2 Get on the vehicle.
 - ▶ Mount the vehicle from the left side, keeping at least one foot on the ground.
- 3 Release the brake lever.

- 4 Acceleration and deceleration
To accelerate: Open the throttle slowly.
To decelerate: Close the throttle.

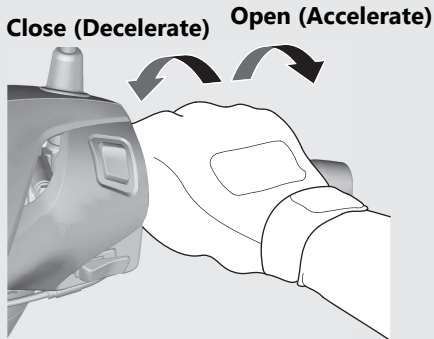

Braking

Close the throttle and apply the front and rear brake levers together.

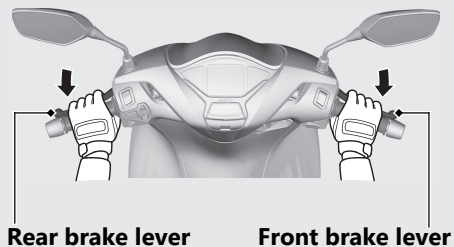

Refuelling

Fuel type: Unleaded petrol only

Fuel octane number: Your vehicle is designed to use Research Octane Number (RON) 95 or higher.

Tank capacity: 7.0 L (1.85 US gal, 1.54 Imp gal)

Refuelling and Fuel Guidelines ➔ P.14

Opening the Fuel Fill Cap

- 1 Turn the ignition switch to the SEAT FUEL position.
 - ▶ To unlock the ignition switch ➔ P.50
- 2 Push the FUEL side of the fuel lid and seat opener switch.
 - ▶ The fuel lid opens.

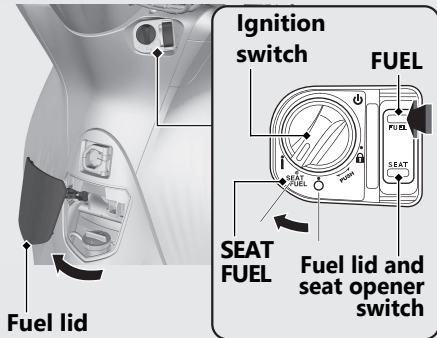

- 3 Turn the fuel fill cap counterclockwise and remove the fuel fill cap.

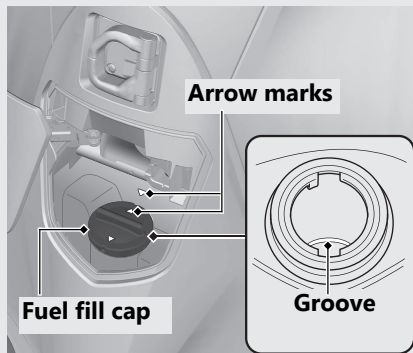

How to Refuel

To refuel with automatic stop filler nozzle:

- 1 Insert the filler nozzle fully.
- ▶ It can be put in easily by swinging nozzle back and forth.

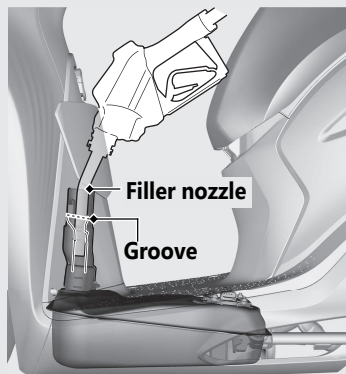

Refuelling *(Continued)*

- ② Refuel until it stops automatically.
 - ▶ When the tank is full, the fuel nozzle will click off automatically.
 - ▶ If the nozzle is not fully inserted, the automatic stop does not function, which may cause fuel to overflow from the fuel filler opening.

To refuel without automatic stop filler nozzle:

Refuel to the groove. Add fuel slowly so it does not overflow from the fuel filler opening.

⚠ WARNING

Petrol is highly flammable and explosive. You can be burned or seriously injured when handling fuel.

- Stop the engine, and keep heat, sparks, and flame away.
- Handle fuel only outdoors.
- Wipe up spills immediately.

⚠ CAUTION

Do not add fuel after the filler nozzle automatically stops.

The filler nozzle automatically stops to leave space in the fuel tank so that fuel does not overflow as a result of changes in air temperature.

Closing the Fuel Fill Cap

- ① Install and tighten the fuel fill cap firmly by turning it clockwise.
 - ▶ Make sure that the arrow marks on the cap and fuel tank are aligned.
- ② Close the fuel lid until it locks.
 - ▶ Make sure that the fuel lid is closed securely.

USB Socket

The USB socket is located in the centre compartment.

Use USB devices at your own risk. In no event shall Honda be liable for any damage to your USB device when in use.

Only USB devices within the following specifications can be connected.

Open the cover to access the USB socket.

Rated capacity is

7.5 W (5 V, 1.5 A).

Do not connect USB devices that exceed the rated capacity. They may not be charged or work properly even if connected.

For information on usage or malfunction of the USB device you connect, refer to its instruction manual.

To connect your USB device

- 1 Open the seat. ➔ P.69
- 2 Open the cover to access the USB socket.

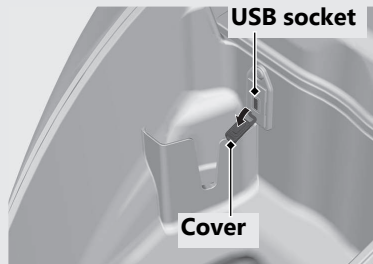

- 3 Connect a certified USB cable to the USB socket.

USB Socket *(Continued)*

- ▶ To prevent the battery from becoming weak (or dead), keep the engine running while drawing current from the USB socket.
- ▶ To prevent entry of foreign matter into the USB socket, be sure to close the cover when the USB socket is not used.
- ▶ Carefully secure all connected devices, as vibration may cause damage to them or they could shift unexpectedly.

NOTICE

- Using any heat-generating USB devices or improperly rated USB devices can damage the USB socket.
- Do not use the USB socket in wet conditions, when or while washing or any other wet conditions as these will damage the USB socket.
- Do not allow the USB's harness to become pinched or trapped.

Storage Equipment

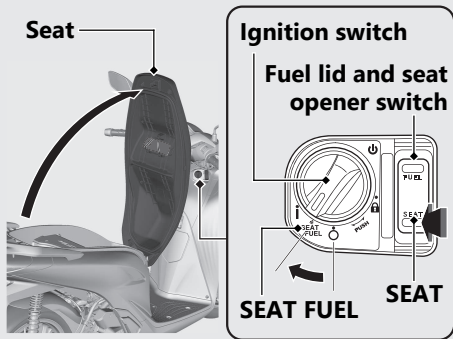

Seat Open

- 1 Turn the handlebar pointed straight ahead.
- 2 Turn the ignition switch to the position of SEAT FUEL.
 - ▶ To unlock the ignition switch. ➔ P.50
- 3 Push the SEAT side of the fuel lid and seat opener switch.
- 4 Open the seat.

Seat Close

Close and push down on the rear of the seat until locks. Make sure that the seat is locked securely to pull it up lightly. Take care not to lock your keys in the compartment under the seat.

Storage Equipment *(Continued)*

Helmet Holders

The helmet holders are located under the seat.

- ▶ Use the helmet holders only when parked.

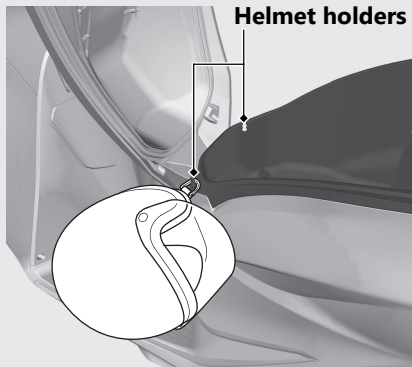

Opening the Seat  P.69

WARNING

Riding with a helmet attached to the holder can interfere with your ability to safely operate the vehicle and could lead to a crash in which you can be seriously hurt or killed.

Use the helmet holder only while parked. Do not ride with a helmet secured by the holder.

A helmet can be stored in the centre compartment.

Set in the front of the helmet forward.

- ▶ Some helmets may not fit in the compartment due to their size or design.

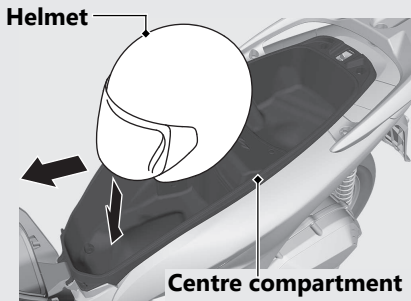

Centre compartment

Never exceed the maximum weight limit.

Maximum Weight: 10 kg (22 lb)

- ▶ Do not store any items that are flammable or susceptible to heat damage.
- ▶ Do not store valuables or fragile articles.

Opening the Seat → P.69

Storage Equipment *(Continued)*

Document Bag

The document bag is in the centre compartment. The owner's manual should be stored the document bag and placed in the centre compartment.

Owner's manual

Document bag

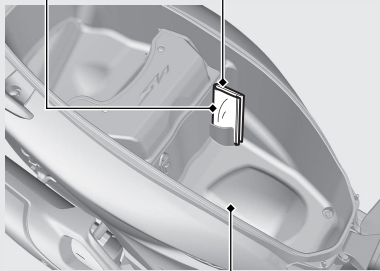

Centre compartment

Tool Kit

The tool kit is in the reverse side of the seat by the rubber strap.

Tool kit

Rubber strap

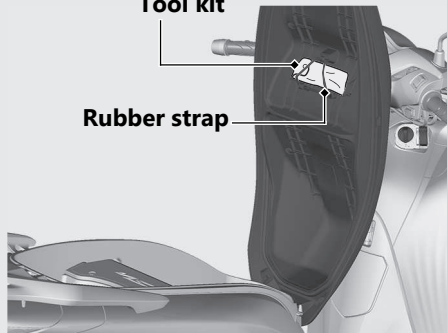

| Opening the Seat ➡ P.69

| Opening the Seat ➡ P.69

Shopping Hook

The shopping hook is provided below the handlebar.

- ▶ Do not attach large luggage to the hook that would hang out from the vehicle and/or interfere with the movement of your feet.



The maximum allowable load on the shopping hook shall be no more than **1.5 kg (3.3 lb)**.

Rear Carrier

Never exceed the maximum weight limit.

Maximum Weight: 3 kg (6.6 lb)

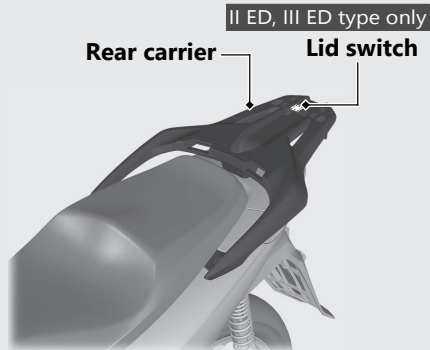

II ED, III ED type only

Lid switch is used for optional parts.

Maintenance

Please read “Importance of Maintenance” and “Maintenance Fundamentals” carefully before attempting any maintenance. Refer to “Specifications” for service data.

| | | | |
|---|--------|--|--------|
| Importance of Maintenance | P. 75 | Throttle | P. 108 |
| Maintenance Schedule | P. 76 | Crankcase Breather | P. 109 |
| Maintenance Fundamentals | P. 79 | Other Adjustments | P. 110 |
| Tool | P. 90 | Adjusting the Headlight Aim..... | P. 110 |
| Removing & Installing Body Components .. | P. 91 | Adjusting the Rear Suspension..... | P. 111 |
| Battery | P. 91 | Other Replacement | P. 112 |
| Battery Cover..... | P. 93 | Replacing the Honda SMART Key Battery .. | P. 112 |
| Clip | P. 94 | | |
| Maintenance Lid | P. 95 | | |
| Spark Plug | P. 96 | | |
| Engine Oil | P. 98 | | |
| Coolant | P. 102 | | |
| Brakes | P. 105 | | |
| Side Stand | P. 107 | | |

Importance of Maintenance

Importance of Maintenance

Keeping your vehicle well-maintained is absolutely essential to your safety and to protect your investment, obtain maximum performance, avoid breakdowns, and reduce air pollution. Maintenance is the owner's responsibility. Be sure to inspect your vehicle before each ride, and perform the periodic checks specified in the Maintenance Schedule.

➔ P. 76

⚠WARNING

Improperly maintaining your vehicle or failing to correct a problem before you ride can cause a crash in which you can be seriously hurt or killed.

Always follow the inspection and maintenance recommendations and schedules in this owner's manual.

Maintenance Safety

Always read the maintenance instructions before you begin each task, and make sure that you have the tools, parts, and skills required. We cannot warn you of every conceivable hazard that can arise in performing maintenance. Only you can decide whether or not you should perform a given task.

Follow these guidelines when performing maintenance.

- Stop the engine and turn the ignition switch to the **○** (Off) position.
- Place your vehicle on a firm, level surface using the side stand, centre stand or a maintenance stand to provide support.
- Allow the engine, muffler, brakes, and other high-temperature parts to cool before servicing as you can get burned.
- Run the engine only when instructed, and do so in a well-ventilated area.

Maintenance Schedule

The maintenance schedule specifies the maintenance requirements necessary to ensure safe, dependable performance, and proper emission control.

Maintenance work should be performed in accordance with Honda's standards and specifications by properly trained and equipped technicians. Your dealer meets all of these requirements. Keep an accurate record of maintenance to help ensure that your vehicle is properly maintained.

Make sure that whomever performs the maintenance completes this record.

All scheduled maintenance is considered a normal owner operating cost and will be charged to you by your dealer. Retain all receipts. If you sell the vehicle, these receipts should be transferred with the vehicle to the new owner.

Honda recommends that your dealer should road test your vehicle after each periodic maintenance is carried out.

| Items | Pre-ride Check ☞ P. 79 | Frequency *1 | | | | | | | | | Annual Check | Regular Replace | Refer to page |
|-------------------------------------|------------------------------|--------------|-----|---|----|----|----|----|----|---|-----------------|--------------------|------------------|
| | | × 1,000 km | 1 | 6 | 12 | 18 | 24 | 30 | 36 | | | | |
| | | × 1,000 mi | 0.6 | 4 | 8 | 12 | 16 | 20 | 24 | | | | |
| Fuel Line | 🔧 | | | I | I | I | I | I | I | I | I | | - |
| Fuel Level | | I | | | | | | | | | | | - |
| Throttle Operation | 🔧 | I | | I | I | I | I | I | I | I | I | | 108 |
| Air Cleaner *2 | 🔧 | | | | | R | | | | R | | | 89 |
| Crankcase Breather *3 | | | | C | C | C | C | C | C | C | | | 109 |
| Spark Plug | | | | I | R | I | R | I | R | | | | 96 |
| Valve Clearance | 🔧 | | | I | I | I | I | I | I | I | | | - |
| Engine Oil | | I | R | R | R | R | R | R | R | R | R | | 99 |
| Engine Oil Strainer Screen | | | | | C | | | C | | C | | | 99 |
| Engine Idle Speed | 🔧 | | | I | I | I | I | I | I | I | I | | - |
| Radiator Coolant *4 | | I | | | I | | | I | | I | I | 3 Years | 102 |
| Cooling System | 🔧 | | | | I | | | I | | I | I | | - |
| Evaporative Emission Control System | 🔧 | | | | | I | | | | I | | | - |

Maintenance Level

🔧 : Intermediate. We recommend service by your dealer, unless you have the necessary tools and are mechanically skilled.

Procedures are provided in an official Honda Shop Manual.

🔧 : Technical. In the interest of safety, have your vehicle serviced by your dealer.









Maintenance Legend

I : Inspect (clean, adjust, lubricate, or replace, if necessary)

R : Replace

C : Clean

Maintenance Schedule

| Items | Pre-ride Check P. 79 | Frequency *1 | | | | | | | | Annual Check | Regular Replace | Refer to page | |
|------------------------|---|--------------|-----|---|----|----|----|----|----|--------------|-----------------|---------------|-----|
| | | × 1,000 km | 1 | 6 | 12 | 18 | 24 | 30 | 36 | | | | |
| | | × 1,000 mi | 0.6 | 4 | 8 | 12 | 16 | 20 | 24 | | | | |
| Drive Belt |  | | | | I | | R | | I | | | – | |
| Final Drive Oil *4 |  | | | | | | | | | | | 2 Years | – |
| Battery |  | | | I | I | I | I | I | I | I | | | 82 |
| Brake Fluid *4 | | I | | I | I | I | I | I | I | I | | 2 Years | 105 |
| Brake Pads Wear | | I | | I | I | I | I | I | I | I | | | 106 |
| Brake System | | | | I | I | I | I | I | I | I | | | 79 |
| Headlight Aim | | | | I | I | I | I | I | I | I | | | 110 |
| Lights/Horn | | I | | | | | | | | | | | – |
| Clutch Shoes Wear |  | | | | I | | | I | | I | | | – |
| Side Stand | | I | | I | I | I | I | I | I | I | | | 107 |
| Suspension |  | | | I | I | I | I | I | I | I | | | – |
| Nuts, Bolts, Fasteners |  | | | | I | | | I | | I | | | – |
| Wheels/Tyres |  | I | | I | I | I | I | I | I | I | | | 86 |
| Steering Head Bearings |  | | | | I | | | I | | I | | | – |

Notes:

*1: At higher odometer reading, repeat at the frequency interval established here.

*2: Service more frequently when riding in unusually wet or dusty areas.

*3: Service more frequently when riding in rain or at full throttle.

*4: Replacement requires mechanical skill.

Pre-ride Inspection

To ensure safety, it is your responsibility to perform a pre-ride inspection and make sure that any problem you find is corrected. A pre-ride inspection is a must, not only for safety, but because having a breakdown, or even a flat tyre, can be a major inconvenience.

Check the following items before you get on your vehicle:

- Fuel level - Fill fuel tank when necessary. ➤ P. 64
- Throttle - Check for smooth opening and full closing in all steering positions. ➤ P. 108
- Engine oil level - Add engine oil if necessary. Check for leaks. ➤ P. 98
- Coolant level - Add coolant if required. Check for leaks. ➤ P. 102

- Brakes - Check operation; Front and Rear: check brake fluid level and pads wear. ➤ P. 105, ➤ P. 106
- Lights and horn - Check that lights, indicators and horn function properly.
- Side stand ignition cut-off system - Check for proper function. ➤ P. 107
- Wheels and tyres - Check condition, air pressure and adjust if necessary. ➤ P. 86

Replacing Parts

Always use Honda Genuine Parts or their equivalents to ensure reliability and safety. When ordering coloured components, specify the model name, colour, and code mentioned on the colour label.

The colour label is attached to the centre compartment under the seat. ➔ P. 69

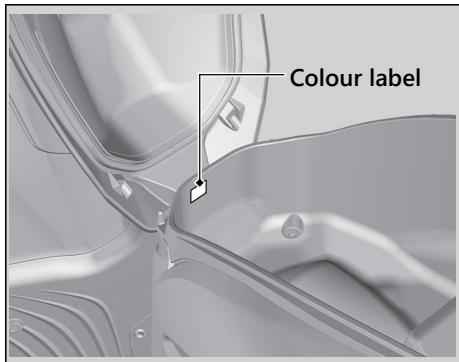

⚠️ WARNING

Installing non-Honda parts may make your vehicle unsafe and cause a crash in which you can be seriously hurt or killed.

Always use Honda Genuine Parts or equivalents that have been designed and approved for your vehicle.

Battery

Your vehicle has a maintenance-free type battery. You do not have to check the battery electrolyte level or add distilled water. Clean the battery terminals if they become dirty or corroded.

Do not remove the battery cap seals. There is no need to remove the cap when charging.

NOTICE

Your battery is a maintenance-free type and can be permanently damaged if the cap strip is removed.



This symbol on the battery means that this product must not be treated as household waste.

NOTICE

An improperly disposed of battery can be harmful to the environment and human health. Always confirm local regulations for proper battery disposal instruction.

What to do in an emergency

If any of the following occur, immediately see your doctor.

- Electrolyte splashes into your eyes:
 - ▶ Wash your eyes repeatedly with cool water for at least 15 minutes. Using water under pressure can damage your eyes.
- Electrolyte splashes onto your skin:
 - ▶ Remove affected clothing and wash your skin thoroughly using water.
- Electrolyte splashes into your mouth:
 - ▶ Rinse mouth thoroughly with water, and do not swallow.

WARNING

The battery gives off explosive hydrogen gas during normal operation.

A spark or flame can cause the battery to explode with enough force to kill or seriously hurt you.

Wear protective clothing and a face shield, or have a skilled mechanic do the battery servicing.

Cleaning the Battery Terminals

1. Remove the battery. ➤ P. 91
2. If the terminals are starting to corrode and are coated with a white substance, wash with warm water and wipe clean.

- If the terminals are heavily corroded, clean and polish the terminals with a wire brush or sandpaper. Wear safety glasses.

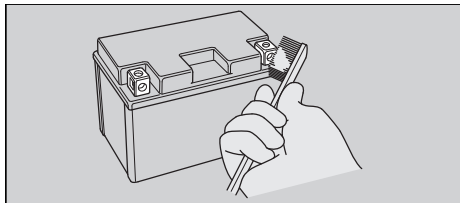

- After cleaning, reinstall the battery.

The battery has a limited life span. Consult your dealer about when you should replace the battery. Always replace the battery with another maintenance-free battery of the same type.

NOTICE

Installing non-Honda electrical accessories can overload the electrical system, discharging the battery and possibly damaging the system.

Fuses

Fuses protect the electrical circuits on your vehicle. If something electrical on your vehicle stops working, check for and replace any blown fuses. ➤ P. 136

Inspecting and Replacing Fuses

Turn the ignition switch to the **○** (Off) position to remove and inspect fuses. If a fuse is blown, replace with a fuse of the same rating. For fuse ratings, see "Specifications." ➤ P. 154

Blown fuse

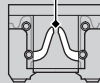

NOTICE

Replacing a fuse with one that has a higher rating greatly increases the chance of damage to the electrical system.

Maintenance Fundamentals

If a fuse fails repeatedly, you likely have an electrical fault. Have your vehicle inspected by your dealer.

Engine Oil

Engine oil consumption varies and oil quality deteriorates according to riding conditions and time elapsed.

Check the engine oil level regularly, and add the recommended engine oil if necessary. Dirty oil or old oil should be changed as soon as possible.

Selecting the Engine Oil

For recommended engine oil, see "Specifications." ➤ P. 153

If you use non-Honda engine oil, check the label to make sure that the oil satisfies all of the following standards:

- JASO T 903 standard*1: MB
- SAE standard*2: 10W-30
- API classification*3: SG or higher

- *1. The JASO T 903 standard is an index for engine oils for 4-stroke motorcycle engines. There are two classes: MA and MB. For example, the following label shows the MB classification.

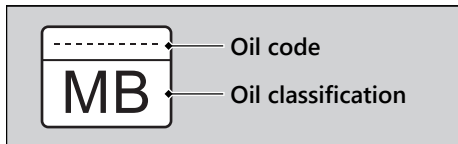

- *2. The SAE standard grades oils by their viscosity.
- *3. The API classification specifies the quality and performance rating of engine oils. Use SG or higher oils, excluding oils marked as "Energy Conserving" or "Resource Conserving" on the circular API service symbol.

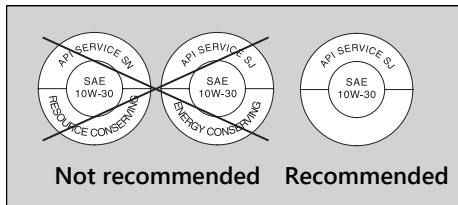

Brake Fluid

Do not add or replace brake fluid, except in an emergency. Use only fresh brake fluid from a sealed container. If you do add fluid, have the brake system serviced by your dealer as soon as possible.

NOTICE

Brake fluid can damage plastic and painted surfaces.
Wipe up spills immediately and wash thoroughly.

Recommended brake fluid:

Honda DOT 3 or DOT 4 Brake Fluid or equivalent

Recommended Coolant

Pro Honda HP Coolant is a pre-mixed solution of antifreeze and distilled water.

Concentration:

50% antifreeze and 50% distilled water

A concentration of antifreeze below 40% will not provide proper corrosion and cold temperature protection.

A concentration of up to 60% will provide better protection in colder climates.

NOTICE

Using coolant not specified for aluminium engines or tap/mineral water can cause corrosion.

Crankcase Breather

Service more frequently when riding in rain, at full throttle, or after the vehicle is washed or overturned. Service if the deposit level can be seen in the transparent section of the drain tube.

If the drain tube overflows, the air filter may become contaminated with engine oil causing poor engine performance. 📄 P. 109

Tyres (Inspecting/Replacing)

Checking the Air Pressure

Visually inspect your tyres and use an air pressure gauge to measure the air pressure at least once a month or any time you think the tyres look low. Always check air pressure when your tyres are cold.

Inspecting for Damage

Inspect the tyres for cuts, slits, or cracks that exposes fabric or cords, or nails or other foreign objects embedded in the side of the tyre or the tread.

Also inspect for any unusual bumps or bulges in the side walls of the tyres.

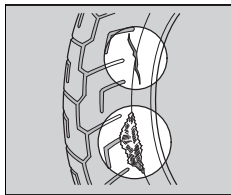

Inspecting for Abnormal Wear

Inspect the tyres for signs of abnormal wear on the contact surface.

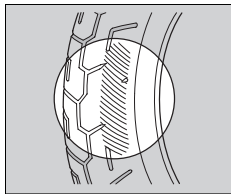

Inspecting Tread Depth

Inspect the tread wear indicators. If they become visible, replace the tyres immediately.

SH150AD

For safe riding, you should replace the tyres when the minimum tread depth is reached.

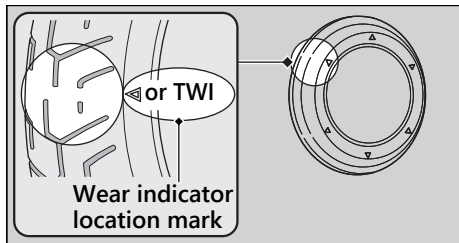

⚠ WARNING

Riding on tyres that are excessively worn or improperly inflated can cause a crash in which you can be seriously hurt or killed.

Follow all instructions in this owner's manual regarding tyre inflation and maintenance.

Germany (SH150AD only)

German law prohibits use of tyres whose tread depth is less than 1.6 mm.

Maintenance Fundamentals

Have your tyres replaced by your dealer.

SH125AD

For recommended tyres and air pressure, see "Specifications." ➔ P. 153

SH150AD

For recommended tyres, air pressure and minimum tread depth, see "Specifications."

➔ P. 153

Follow these guidelines whenever you replace tyres.

- Use the recommended tyres or equivalents of the same size, construction, speed rating, and load range.
- **Front wheel only** Have the wheel balanced with Honda Genuine balance weights or equivalent after the tyre is installed.
- Do not install a tube inside a tubeless tyre on this vehicle. Excessive heat build-up can cause the tube to burst.

- Use only tubeless tyres on this vehicle. The rims are designed for tubeless tyres, and during hard acceleration or braking, a tube-type tyre could slip on the rim and cause the tyre to rapidly deflate.

WARNING

Installing improper tyres on your vehicle can adversely affect handling and stability, and can cause a crash in which you can be seriously hurt or killed.

Always use the size and type of tyres recommended in this owner's manual.

Air Cleaner

This vehicle is equipped with a viscous type air cleaner element.

Air blow cleaning or any other cleaning can degrade the viscous element performance and cause the intake of dust.

Do not perform the maintenance. Should be serviced by your dealer.

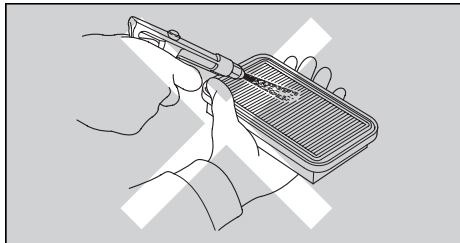

The tool kit is in reverse side of the seat. ➔ P. 69

You can perform some roadside repairs, minor adjustments and parts replacement with the provided tools.

- Standard/Phillips screwdriver
- Screwdriver handle
- 10 × 14 mm Open end wrench
- Pin spanner
- Extension bar
- EM mode coupler

Battery

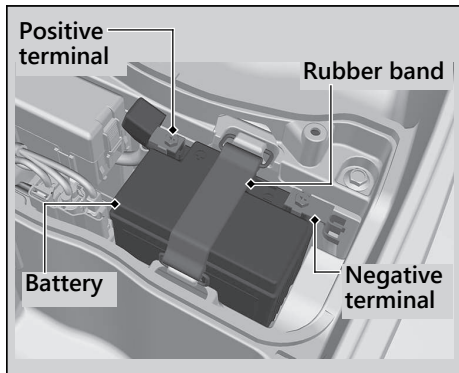

Removal

Make sure the ignition switch is in the \bigcirc (Off) position.

1. Remove the battery cover. ➤ P. 93
2. Unhook the rubber band.
3. Disconnect the negative \ominus terminal from the battery.
4. Disconnect the positive \oplus terminal from the battery.
5. Remove the battery taking care not to drop the terminal nuts.

Installation

Install the parts in the reverse order of removal. Always connect the positive ⊕ terminal first. Make sure that bolts and nuts are tight.

Make sure the clock information is correct after the battery is reconnected. ➤ P. 33

For proper handling of the battery, see "Maintenance Fundamentals." ➤ P. 81
"Battery Goes Dead." ➤ P. 133

Battery Cover

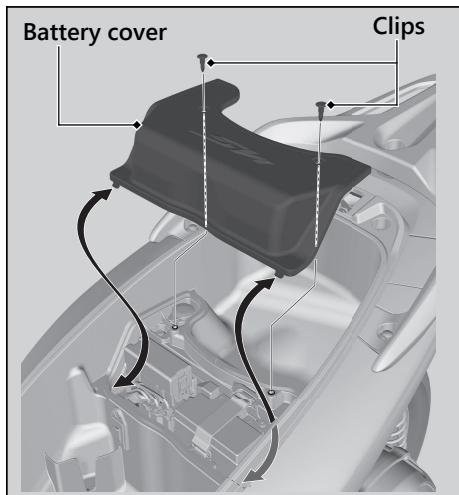

Removal

1. Open the seat. ► P. 69
2. Remove the battery cover by removing the clips. ► P. 94

Installation

Install the parts in the reverse order of removal.

Clip

Removal

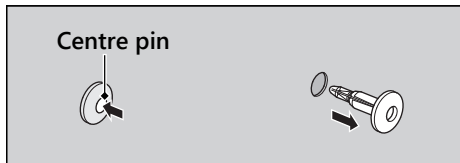

1. Press down on the centre pin to release the lock.
2. Pull the clip out of the hole.

Installation

1. Push the bottom of the centre pin.

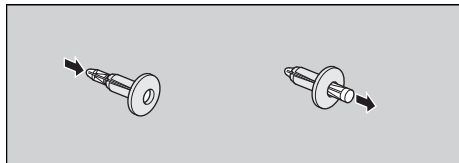

2. Insert the clip into the hole.
3. Press down on the centre pin to lock the clip.

Maintenance Lid

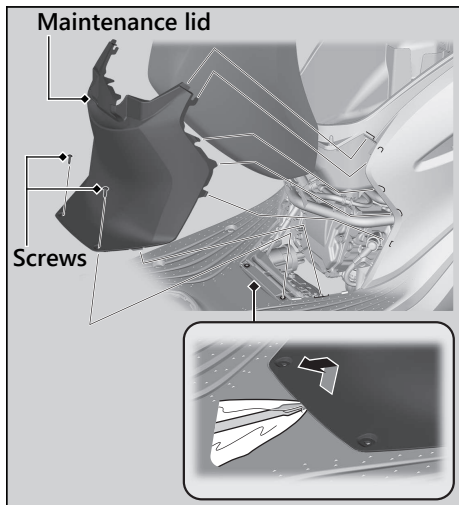

Removal

1. Open the seat. ► P. 69
2. Remove the screws.
3. Remove the maintenance lid by inserting a flat head screwdriver covered with a protective cloth into the slit on the floor.

Installation

Install the parts in the reverse order of removal.

Checking Spark Plug

For the recommended spark plug, see "Specifications." P. 153

Use only the recommended type of spark plug in the recommended heat range.

NOTICE

Using a spark plug with an improper heat range can cause engine damage.

1. Remove the maintenance lid. P. 95
2. Disconnect the spark plug cap from the spark plug.
3. Clean any dirt from around the spark plug base.
4. Remove the spark plug using a suitable spark plug wrench.

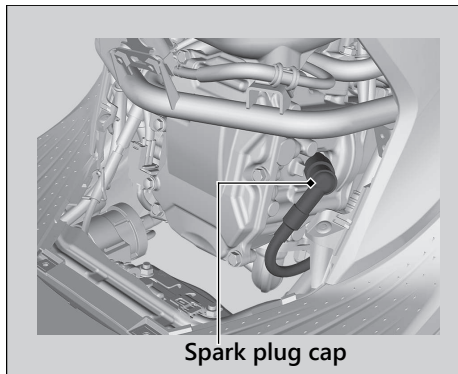

5. Inspect the electrodes and centre porcelain for deposits, erosion or carbon fouling.
 - ▶ If the erosion or deposit is heavy, replace the plug.
 - ▶ Clean a carbon or wet-fouled plug with a plug cleaner, otherwise use a wire brush.

6. Check the spark plug gap using a wire-type feeler gauge.
- If adjustment is necessary, bend the side electrode carefully.

The gap should be:

0.8 - 0.9 mm (0.03 - 0.04 in)

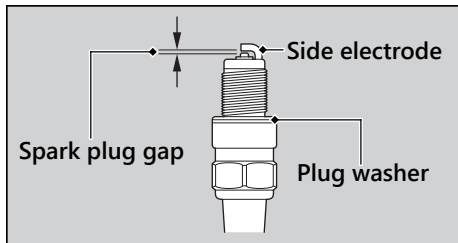

7. Make sure the plug washer is in good condition.
8. Install the spark plug. With the plug washer attached, thread the spark plug in by hand to prevent cross-threading.

9. Tighten the spark plug:
- If the old plug is good:
 - 1/8 turn after it seats
 - If installing a new plug, tighten it twice to prevent loosening:
 - a) First, tighten the plug:
 - 1/2 turn after it seats
 - b) Then loosen the plug.
 - c) Next, tighten the plug again:
 - 1/8 turn after it seats

NOTICE

An improperly tightened spark plug can damage the engine. If a plug is too loose, a piston may be damaged. If a plug is too tight, the threads may be damaged.

10. Install the parts in the reverse order of removal.
- When reinstalling the spark plug cap, take care to avoid pinching any cables or wires.

Checking the Engine Oil

Check the engine oil with the Idling Stop switch at IDLING.

1. If the engine is cold, idle the engine for 3 to 5 minutes.
2. Turn the ignition switch to the **O** (Off) position and wait for 2 to 3 minutes.
3. Place your vehicle on its centre stand on a firm, level surface.
4. Remove the oil fill cap/dipstick and wipe it clean.
5. Insert the oil fill cap/dipstick until it seats, but don't screw it in.
6. Check that the oil level is between the upper level and lower level marks on the oil fill cap/dipstick.
7. Securely install the oil fill cap/dipstick.

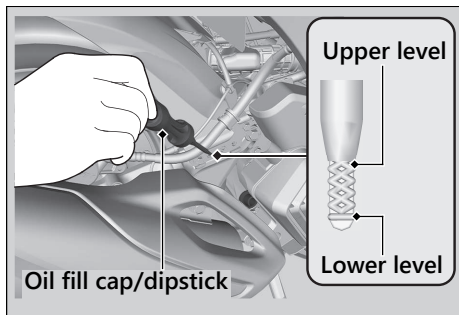

Adding Engine Oil

If the engine oil is below or near the lower level mark, add the recommended engine oil.

► P. 84, ► P. 153

1. Remove the oil fill cap/dipstick. Add the recommended oil until it reaches the upper level mark.
 - Place your vehicle on its centre stand on a firm, level surface when checking the oil level.
 - Do not overfill above the upper level mark.
 - Make sure no foreign objects enter the oil filler opening.
 - Wipe up any spills immediately.
2. Securely reinstall the oil fill cap/dipstick.

NOTICE

Overfilling with oil or operating with insufficient oil can cause damage to your engine. Do not mix different brands and grades of oil.

For the recommended oil and oil selection guidelines, see "Maintenance Fundamentals."

► P. 84

Changing Engine Oil, Cleaning Strainer Screen

Changing the oil and cleaning the strainer screen requires special tools. We recommend that you have your vehicle serviced by your dealer.

Change the engine oil with the Idling Stop switch at IDLING.

1. If the engine is cold, idle the engine for 3 to 5 minutes.
2. Turn the ignition switch to the  (Off) position and wait for 2 to 3 minutes.

Engine Oil ► Changing Engine Oil, Cleaning Strainer Screen

- Place your vehicle on its centre stand on a firm, level surface.
- Place a drain pan under the drain bolt and oil plug.
- Remove the oil fill cap/dipstick, drain bolt and sealing washer to drain the oil.
- Remove the oil plug, O-ring, spring and oil strainer screen and let the remaining oil drain out.
 - Discard the oil at an approved recycling centre.
- Clean the oil strainer screen.
- Check that the oil strainer screen and sealing rubber are in good condition.
- Replace the O-ring and apply a thin coat of engine oil to the new O-ring before installing it.
- Install the oil strainer screen, spring and oil plug and tighten.

Torque: 20 N·m (2.0 kgf·m, 15 lbf·ft)

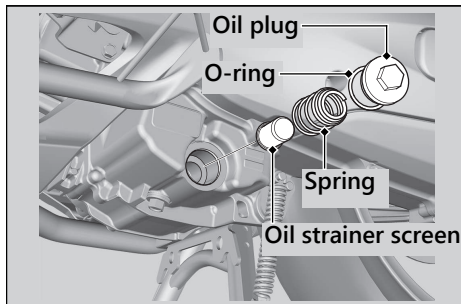
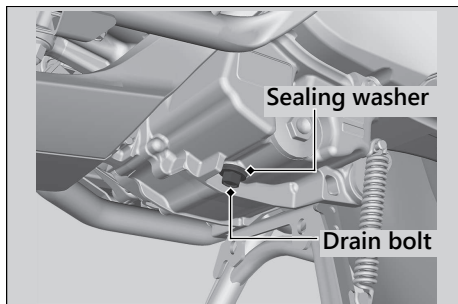

- 11.** Install a new sealing washer onto the drain bolt. Tighten the drain bolt.

Torque: 24 N·m (2.4 kgf·m, 18 lbf·ft)

- 12.** Fill the crankcase with the recommended oil (► P. 84, ► P. 153) and install the oil fill cap/dipstick.

Required oil

When changing oil & cleaning the strainer screen:

0.9 L (1.0 US qt, 0.8 Imp qt)

When changing oil only:

0.8 L (0.8 US qt, 0.7 Imp qt)

- 13.** Check the oil level. ► P. 98
- 14.** Check that there are no oil leaks. After changing the engine oil, reset the oil change indicator. ► P. 33

Checking the Coolant

Check the coolant level in the reserve tank while the engine is cold.

1. Place your vehicle on its centre stand on a firm, level surface.
2. Check that the coolant level is between the UPPER level and LOWER level marks on the reserve tank.

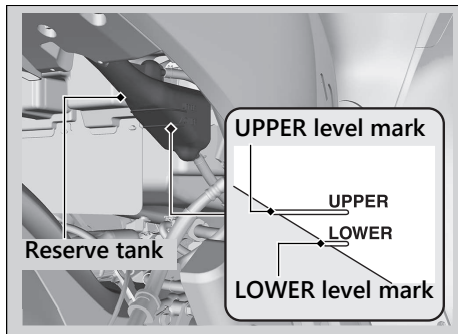

If the coolant level is dropping noticeably or the reserve tank is empty, you likely have a serious leak. Have your vehicle inspected by your dealer.

Adding Coolant

If the coolant level is below the LOWER level mark, add the recommended coolant (► P. 85) until the level reaches the UPPER level mark.

Add fluid only from the reserve tank cap and do not remove the radiator cap.

1. Remove the battery cover. ► P. 93
2. Remove the reserve tank cap and add fluid while monitoring the coolant level.
 - Do not overfill above the UPPER level mark.
 - Make sure no foreign objects enter the reserve tank opening.

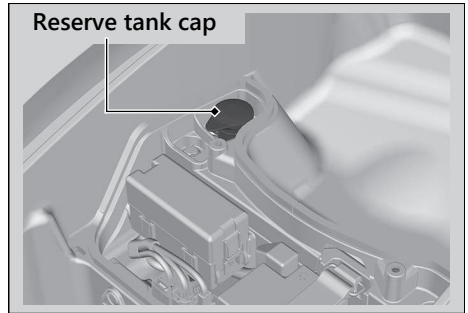

3. Securely reinstall the reserve tank cap.
4. Install the parts in the reverse order of removal.

⚠ WARNING

Removing the radiator cap while the engine is hot can cause the coolant to spray out, potentially scalding you.

Always let the engine and radiator cool down before removing the radiator cap.

Changing Coolant

Have your dealer change the coolant unless you have the proper tools and are mechanically qualified.

Checking Brake Fluid

1. Place your vehicle in an upright position on a firm, level surface.
2. Check that the brake fluid reservoir is horizontal and that the fluid level is above the LOWER level mark.

If the brake fluid level in either reservoir is below the LOWER level mark or both the brake levers freeplay becomes excessive, inspect the brake pads for wear.

If the brake pads are not worn, you most likely have a leak. Have your vehicle inspected by your dealer.

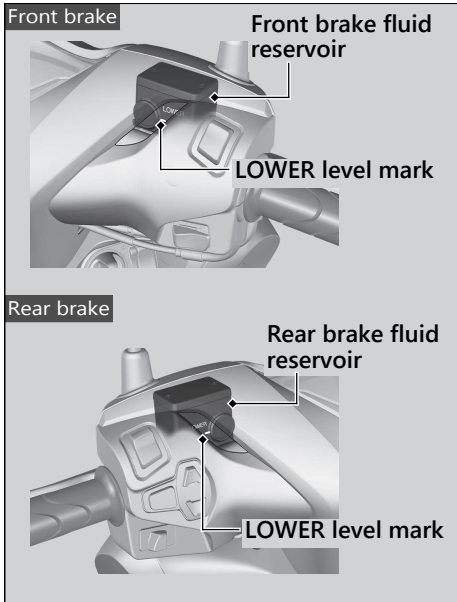

Inspecting the Brake Pads

Check the condition of the brake pad wear indicators.

The pads need to be replaced if a brake pad is worn to the bottom of the indicator.

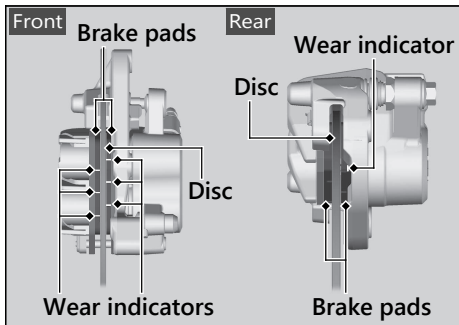

1. **Front** Inspect the brake pads from in front of the brake caliper.
2. **Rear** Inspect the brake pads from the rear left of the vehicle.

If necessary have the pads replaced by your dealer.

Always replace both left and right brake pads at the same time.

Checking the Side Stand



1. Place your vehicle on its centre stand on a firm, level surface.
2. Check that the side stand operates smoothly. If the side stand is stiff or squeaky, clean the pivot area and lubricate the pivot bolt with clean grease.
3. Sit on the vehicle and raise the side stand.
4. Start the engine.
5. Lower the side stand all the way. The engine should stop as you lower the side stand. If the engine doesn't stop, have your vehicle inspected by your dealer.

Checking the Throttle

With the engine off, check that the throttle rotates smoothly from fully closed to fully open in all steering positions and throttle freeplay is correct. If the throttle does not move smoothly, close automatically, or if the cable is damaged, have the vehicle inspected by your dealer.

Freeplay at the throttle grip flange:

2 - 6 mm (0.1 - 0.2 in)

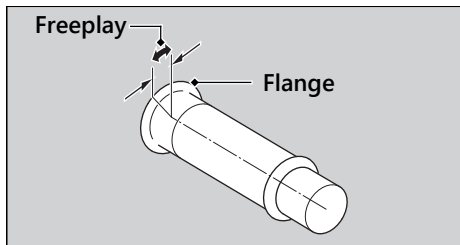

Cleaning the Crankcase Breather

1. Place a suitable container to receive deposits.
2. Remove the crankcase breather plug from the air cleaner case and drain deposits into the container.
3. Reinstall the crankcase breather plug.

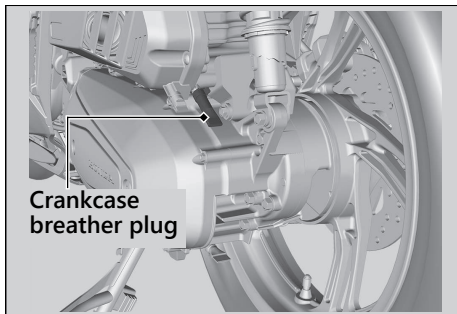

Adjusting the Headlight Aim

You can adjust vertical aim of the headlight for proper alignment. Turn the pinion in or out as necessary using a Phillips screwdriver provided in the tool kit (➤ P. 90).

Obey local laws and regulations.

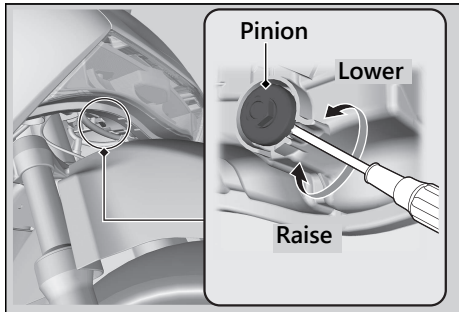

Adjusting the Rear Suspension

I Spring Preload

You can adjust the spring preload by the adjuster to suit the load or the road surface. Use the pin spanner and extension bar to turn the adjuster.

Position 1 is for a decrease spring preload (soft), or turn the position 3 to 5 increase spring preload (hard). The standard position is 2.

NOTICE

Attempting to adjust directly from 1 to 5 or 5 to 1 may damage the shock absorber.

NOTICE

Do not turn the adjuster beyond its limits. Adjust both left and right shock absorbers to the same spring preload.

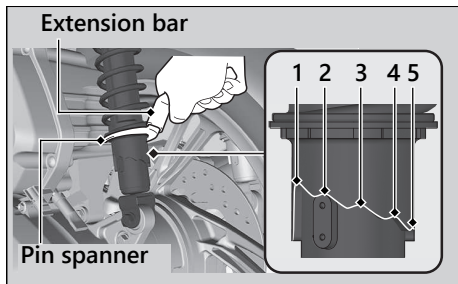

Replacing the Honda SMART Key Battery

If the Honda SMART Key indicator flashes 5 times when the ignition switch is turned to the **I** (On) position, or the operating range becomes unstable, replace the battery as soon as possible.

We recommend to see your dealer for this service.

Battery type: CR2032

1. Remove the upper case by inserting a coin or a flat head screwdriver covered with a protective cloth into the slit.
 - ▶ Wrap a coin or a screwdriver with a protective cloth to prevent scratching the Honda SMART Key.
 - ▶ Do not touch the circuit or terminal. This may cause problems.
 - ▶ Be careful to avoid scratching the waterproof covering or allowing dust to enter.
 - ▶ Do not forcibly dismantle the Honda SMART Key body.

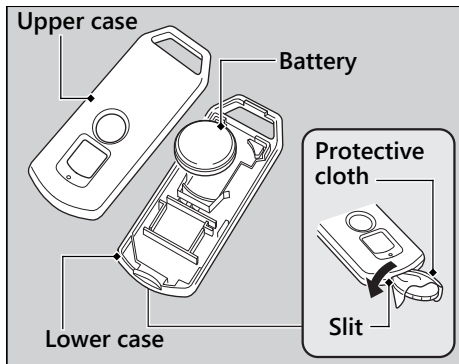

2. Replace the old battery with a new battery with the negative \ominus side facing up.
3. Snap the two halves of the remote transmitter back together.
 - Make sure that upper and lower cases are set in the right position.

⚠ WARNING

Chemical Burn Hazard: do not swallow battery.

If swallowed, the battery can cause severe internal burns and even death.

- Keep battery away from children and battery compartment securely closed.
- If the battery compartment does not close securely, stop using the product and keep it away from children.
- Immediately seek medical attention if a child may have swallowed battery.

Troubleshooting

| | | | |
|---|--------|--|--------|
| Engine Will Not Start | P. 115 | Engine Does Not Start Even If the Throttle is Opened | P. 124 |
| Overheating (High coolant temperature indicator is on) | P. 116 | When the Honda SMART Key System Does Not Operate Properly | P. 125 |
| Warning Indicators On or Flashing | P. 117 | Unlock the Seat in an Emergency | P. 127 |
| PGM-FI (Programmed Fuel Injection) | | Unlock the Ignition Switch in an Emergency | P. 129 |
| Malfunction Indicator Lamp (MIL)..... | P. 117 | Tyre Puncture | P. 132 |
| ABS (Anti-lock Brake System) Indicator..... | P. 118 | Electrical Trouble | P. 133 |
| Torque Control Indicator..... | P. 119 | Battery Goes Dead..... | P. 133 |
| Honda SMART Key Indicator..... | P. 120 | Burned-out Light Bulb..... | P. 133 |
| Other Warning Indications | P. 121 | Blown Fuse..... | P. 136 |
| Fuel Gauge Failure Indication..... | P. 121 | Unstable Engine Operation Occurs Intermittently | P. 137 |
| When the Idling Stop System Does Not Operate Properly | P. 122 | | |
| Idling Stop Indicator Does Not Come On .. | P. 122 | | |
| Engine is Not Stopped by the Idling Stop System While the Idling Stop Indicator is On..... | P. 123 | | |

Starter Motor Operates But Engine Does Not Start

Check the following items:

- Check the correct engine starting sequence. ➤ P. 59
- Check that there is petrol in the fuel tank.
- Check if the PGM-FI malfunction indicator lamp (MIL) is on.
 - ▶ If the indicator lamp is on, contact your dealer as soon as possible.

Starter Motor Does Not Operate

Check the following items:

- Check the correct engine starting sequence. ➤ P. 59
- Check for a blown fuse. ➤ P. 136
- Check for a loose battery connection (➤ P. 91) or battery terminal corrosion (➤ P. 81).
- Check the condition of the battery.
 - P. 133

If the problem continues, have your vehicle inspected by your dealer.

Overheating (High coolant temperature indicator is on)

The engine is overheating when the following occurs:

- High coolant temperature indicator comes on.
- Acceleration becomes sluggish.

If this occurs, pull safely to the side of the road and perform the following procedure. Extended fast idling may cause the high coolant temperature indicator to come on.

NOTICE

Continuing to ride with an overheated engine can cause serious damage to the engine.

1. Stop the engine using the ignition switch.
2. Allow the engine to cool with the ignition switch in the **O** (Off) position.
3. After the engine has cooled, inspect the radiator hose and check if there is a leak.
➔ P. 102
If there is a leak:
Do not start the engine. Transport your vehicle to your dealer.
4. Check the coolant level in the reserve tank. ➔ P. 102
▶ Add coolant as necessary.
5. If 1-4 check normal, you may continue riding, but closely monitor the high coolant temperature indicator.

PGM-FI (Programmed Fuel Injection) Malfunction Indicator Lamp (MIL)

Reasons for the indicator lamp to come on or blink

- Comes on if there is a problem with the engine emissions control system.
- Blinks when engine misfiring is detected.

What to do when the indicator lamp comes on

Avoid high speeds and immediately get your vehicle inspected at a dealer.

What to do when the indicator lamp blinks

Park the vehicle in a safe place with no flammable items and wait at least 10 minutes with the engine stopped until it cools.

NOTICE

If you drive with the malfunction indicator lamp on, the emissions control system and the engine could be damaged.

NOTICE

If the malfunction indicator lamp blinks again when restarting the engine, drive to the nearest dealer at 50 km/h (30 mph) or less. Have your vehicle inspected.

ABS (Anti-lock Brake System) Indicator

If the indicator operates in one of the following ways, you may have a serious problem with the ABS. Reduce your speed and have your vehicle inspected by your dealer as soon as possible.

- Indicator comes on or starts flashing while riding.
- Indicator does not come on when the ignition switch is in the **I** (On) position.
- Indicator does not go off at speeds above 10 km/h (6 mph).

If the ABS indicator stays on, your brakes will continue to work as a conventional system, but without the anti-locking function.

The ABS indicator may flash if you turn the rear wheel while the rear wheel is lifted off the ground. In this case, turn the ignition switch to the **O** (Off) position, and then to the **I** (On) position again. The ABS indicator will go off after your speed reaches 30 km/h (19 mph).

Torque Control Indicator

If the indicator operates in one of the following ways, you may have a serious problem with the Torque Control. Reduce your speed and have your vehicle inspected by your dealer as soon as possible.

- Indicator comes and stays on (solid) while riding.
- Indicator does not come on when the ignition switch is turned to the **I** (On) position.
- Indicator does not go off at speeds above 3 km/h (2 mph).

Even when the Torque Control indicator is on, your vehicle will have normal riding ability without Torque Control function.

- When the indicator comes on while the Torque Control is in operation, you will have to completely close the throttle to regain normal riding ability.

The Torque Control indicator may come on if you rotate the rear wheel while your vehicle is lifted off the ground. In this case, turn the ignition switch to the **O** (Off) position, and then to the **I** (On) position again. The Torque Control indicator will go off after your speed reaches 3 km/h (2 mph).

Honda SMART Key Indicator

When the Honda SMART Key indicator flashes 5 times

Replacing the Honda SMART Key Battery ► P. 112

When the Honda SMART Key indicator is flashing while the ignition switch is in the (On) position

The Honda SMART Key indicator flashes when communication between your vehicle and Honda SMART Key stops after turning the ignition switch to the (On) position. It is probably caused by the following:

- Strong radio waves or noise are affecting the system
- You lose the Honda SMART Key while riding

However, this does not affect the operation of your vehicle until the ignition switch is locked.

If you turn the ignition switch to the SEAT FUEL, (Off) or (Lock) position while the Honda SMART Key indicator is flashing, the ignition switch ring and Honda SMART Key indicator will come on for about 20 seconds, automatically go off, and then the ignition switch is locked.

► Turn signals blink at the beginning and end of this function.

Also, to stop this flashing, press and hold the ignition switch for more than 2 seconds. After the flashing stops, the ignition switch is locked.

If you do not have the Honda SMART Key, the ignition switch can be unlocked in another way. ► P. 129

Other Warning Indications

Fuel Gauge Failure Indication

If the fuel system has an error, the fuel gauge indicators will be displayed as shown in the illustration.

If this occurs, see your dealer as soon as possible.

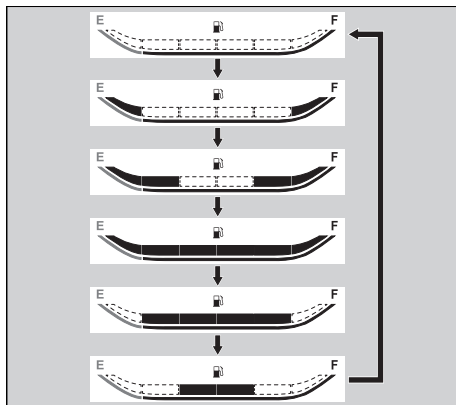
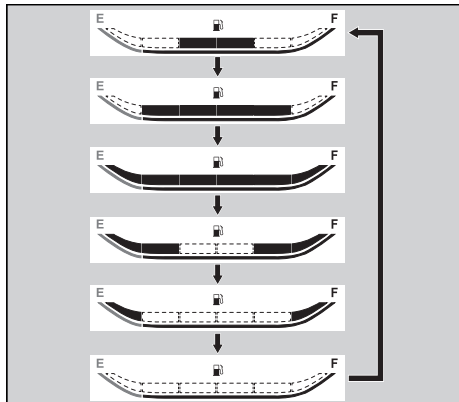

When the Idling Stop System Does Not Operate Properly

Idling Stop Indicator Does Not Come On

When the Idling Stop indicator does not come on, perform the followings.

If the Idling Stop switch is at IDLING:

Press the Idling Stop switch to IDLING STOP.

If the engine is cold:

Warm up the engine.

The Idling Stop system does not operate when the engine is cold.

If you did not ride the vehicle after engine starts:

Ride the vehicle at speeds of over 10 km/h (6 mph). The Idling Stop system does not operate until you ride once.

If PGM-FI malfunction indicator lamp (MIL) lights:

When the PGM-FI malfunction indicator lamp (MIL) lights, the Idling Stop system does not operate for protection of the engine. See your dealer.

If the battery voltage is low:

Ride the vehicle awhile, then stop the engine and then restart the engine with start button referring to the starting procedure (▶ P. 59) for standard engine starting. The Idling Stop system may not operate if the battery voltage is low.

If this occurs frequently, contact your dealer.

Engine is Not Stopped by the Idling Stop System While the Idling Stop Indicator is On

When the engine is not stopped by the Idling Stop system while the Idling Stop indicator is on, perform the followings.

If the vehicle does not stop completely:

Stop the vehicle completely. The Idling Stop system operates if the speed is only at 0 km/h (0 mph).

If the throttle is not closed completely:

Close the throttle completely.

Engine Does Not Start Even If the Throttle is Opened

Engine does not start even if the throttle is opened, perform the followings.

If the side stand is down:

While the engine is stopped by the Idling Stop system, if you operate the side stand, the flashing Idling Stop indicator turns off or stops flashing and stays on, and the Idling Stop system is cancelled. Restart the engine with start button referring to the starting procedure (► P. 59) for standard engine starting.

If the Idling Stop switch is at IDLING:

While the engine is stopping by the Idling Stop system, if you press the Idling Stop switch to IDLING, the Idling Stop system will be cancelled. Restart the engine with start button referring to the starting procedure (► P. 59) for standard engine starting.

If the Idling Stop indicator flashes (the Idling Stop switch is at IDLING STOP position), but engine does not start even if the throttle is opened, perform the followings.

Low (or dead) battery or battery lead is loose:

Check the battery and battery terminals. If the battery is weak, contact your dealer.

When the Honda SMART Key System Does Not Operate Properly

When the Honda SMART Key system does not work properly, perform the following.

- Check that the Honda SMART Key system is activated.

Lightly press the ON/OFF button on the Honda SMART Key.

If the LED of the Honda SMART Key is red, switch the Honda SMART Key system to activation. ➤ P. 46

If the LED of the Honda SMART Key does not respond, replace the battery of the Honda SMART Key.

- Check that there is no communication failure in the Honda SMART Key system. The Honda SMART Key system uses low-intensity radio waves. The Honda SMART Key system may not work properly in the following environments:
 - ▶ When there are facilities nearby that generate strong radio waves or noise such as TV towers, power stations, radio stations, or airports.
 - ▶ When you carry the Honda SMART Key with a laptop or wireless communication device such as a radio or mobile phone.
 - ▶ When the Honda SMART Key comes into contact with or is covered by metal objects.

When the Honda SMART Key System Does Not Operate Properly

- Check that a registered Honda SMART Key is used.
Use a registered Honda SMART Key.
The Honda SMART Key system cannot be activated without a registered Honda SMART Key.
- Make sure that you do not use a broken Honda SMART Key.
If you use a broken Honda SMART Key, the Honda SMART Key system cannot be activated. Bring the emergency key and ID tag to your dealer.

- Check the battery condition and battery lead in your vehicle.
Check the battery and battery terminals. If the battery is weak, contact your dealer.

If the Honda SMART Key system cannot be activated due to other causes, contact your dealer.

Unlock the Seat in an Emergency

The seat lock can be unlocked by using the emergency key.

Open

1. Remove the front lid by pushing the side of the front lid.

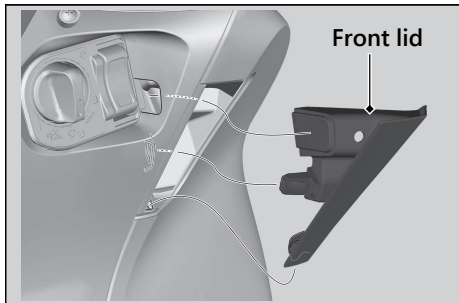
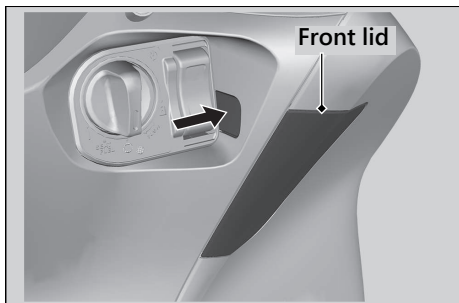

Unlock the Seat in an Emergency

2. Align the projection of the emergency key with the slot of the emergency seat opener, and turn the emergency key counterclockwise.
3. Open the seat and turn the emergency key clockwise.

Close

1. Close and push down on the rear of the seat until it locks. Make sure that the seat is locked securely by pulling it up lightly. If the seat is not locked, turn the emergency key clockwise to lock the seat catch.
2. Install the front lid in the reverse order of removal.

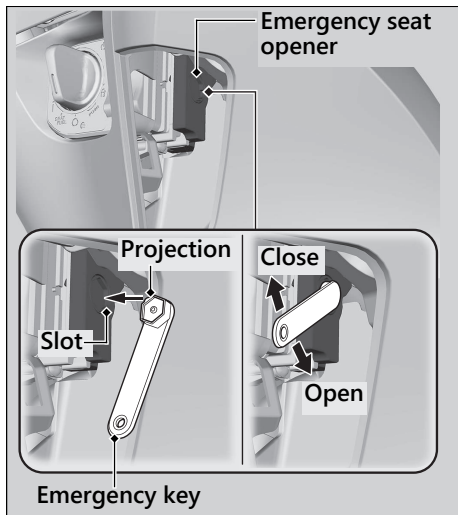

Unlock the Ignition Switch in an Emergency

Set up to ID number input mode

1. Use the emergency key to open the seat. **➤** P. 127
2. Remove the battery cover. **➤** P. 93
3. Pull out the EM mode connector.
4. Remove the blue dummy coupler by releasing the tab of the EM mode connector while lifting the hook of the blue dummy coupler.
5. Check the ID number on the ID tag.
6. Connect the EM mode coupler provided in the tool kit to the EM mode connector.

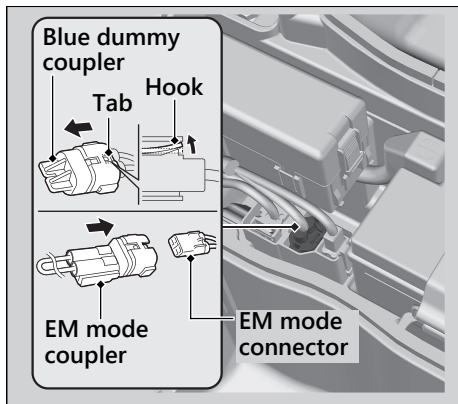

Unlock the Ignition Switch in an Emergency

ID number input

You can input your ID number by pressing the ignition switch when the ignition switch is in the **O** (Off), **L** (Lock) or SEAT FUEL position. Input the ID number on the ID tag in order from the left in turn by pressing the ignition switch.

The ID number is authenticated according to the number of times the ignition switch is pushed.

Push the ignition switch the desired number of times within 5 seconds when the ignition switch ring comes on. After 5 seconds, the ignition switch ring goes off and comes on again. This means that the inputted number is fixed, and you can input the next number.

- ▶ If the ignition switch ring does not come on in blue, the battery may be low. Contact your dealer.

Example:

- To input "0", wait for 5 seconds without pushing the ignition switch when the ignition switch ring comes on.
- To input "1", push the ignition switch once within 5 seconds when the ignition switch ring comes on.

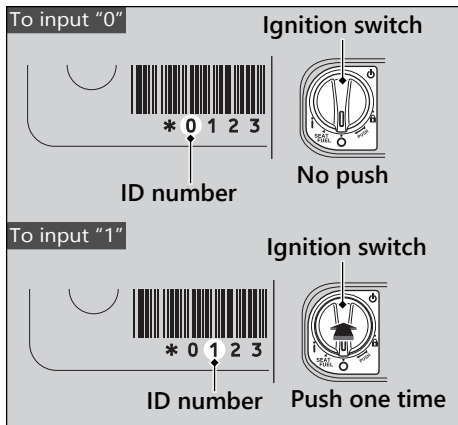

ID number input success

After the last ID number is inputted, through the ignition switch ring and Honda SMART Key Indicator will flash every 2 seconds until the EM mode coupler is removed.

Be sure to remove the EM mode coupler and return the blue dummy coupler. The ignition switch is then unlocked. Reinstall the parts in reverse order of removal and turn the ignition switch to the **I** (On) position within 6 minutes. You can start the engine.

To lock the ignition switch, turn the ignition switch to the SEAT FUEL, **O** (Off), or **L** (Lock) position, and press and hold the ignition switch for 2 seconds. The ignition switch also locks automatically when the ignition switch has been in the SEAT FUEL, **O** (Off), or **L** (Lock) position for about 6 minutes after the ID number is successfully inputted.

When the ignition switch is locked, the ignition switch ring goes off.

To unlock the ignition switch again, repeat the procedure for unlocking the ignition switch.

ID number input failure

After the last ID number is inputted, the ignition switch ring and Honda SMART Key Indicator will flash every second until the EM mode coupler is removed, and the ignition switch cannot be unlocked.

Pull out the EM mode coupler and reconnect it to the EM mode connector. Follow the procedure again. ➔ P. 130

ID number input cancel

Pull out the EM mode coupler from the EM mode connector.

Also, if you make a mistake while inputting the ID number, remove the EM mode coupler from the EM mode connector, connect it to the EM mode connector again, and then re-input the ID number from the beginning.

- Store the removed EM mode coupler in the tool kit at all times.

Tyre Puncture

Repairing a puncture or removing a wheel requires special tools and technical expertise. We recommend you have this type of service performed by your dealer.

After an emergency repair, always have the tyre inspected/replaced by your dealer.

Emergency Repair Using a Tyre Repair Kit

If your tyre has a minor puncture, you can make an emergency repair using a tubeless tyre repair kit.

Follow the instructions provided with the emergency tyre repair kit.

Riding your vehicle with a temporary tyre repair is very risky. Do not exceed 50 km/h (30 mph). Have the tyre replaced by your dealer as soon as possible.

WARNING

Riding your vehicle with a temporary tyre repair can be risky. If the temporary repair fails, you can crash and be seriously injured or killed.

If you must ride with a temporary tyre repair, ride slowly and carefully and do not exceed 50 km/h (30 mph) until the tyre is replaced.

Battery Goes Dead

Charge the battery using a motorcycle battery charger.

Remove the battery from the vehicle before charging.

Do not use an automobile-type battery charger, as these can overheat a motorcycle battery and cause permanent damage. If the battery does not recover after recharging, contact your dealer.

NOTICE

Jump starting using an automobile battery can damage your vehicle's electrical system and is not recommended.

Burned-out Light Bulb

All light bulbs on the vehicle are LEDs. If there is an LED which is not turned on, see your dealer for servicing.

Headlight/Front Turn Signals/ Position Light

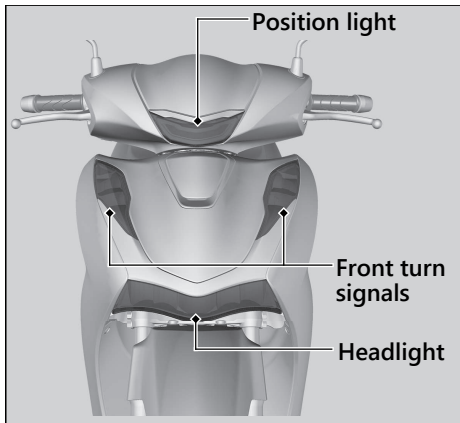

The headlight/front turn signals use several LEDs.

The position light uses a several LED.

If there is an LED which is not turned on, see your dealer for servicing.

Brakelight/Taillight/Rear Turn Signals/License Plate Light

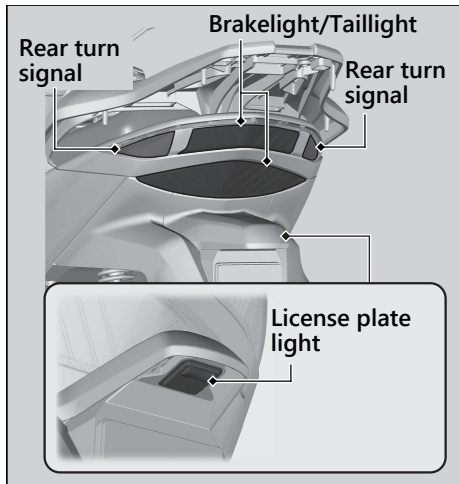

The brakelight/taillight/rear turn signals use several LEDs.

The license plate light uses a several LED.

If there is an LED which is not turned on, see your dealer for servicing.

Blown Fuse

Before handling fuses, see “Inspecting and Replacing Fuses.” ► P. 83

Fuse Box Fuses

1. Remove the battery cover. ► P. 93
2. Remove the fuse box cover.
3. Pull the fuses out one by one with the fuse puller located back side of the fuse box cover. Check for a blown fuse. Always replace a blown fuse with a spare fuse of the same rating.
 - Spare fuses are provided on the back side of the fuse box cover.
4. Install the fuse box cover.
5. Install the battery cover.

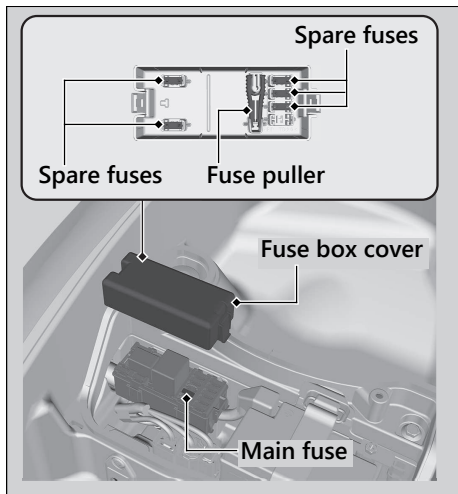

NOTICE

If a fuse fails repeatedly, you likely have an electrical problem. Have your vehicle inspected by your dealer.

Unstable Engine Operation Occurs Intermittently

If the fuel pump filter is clogged, unstable engine operation will occur intermittently while riding.

Even if this symptom occurs, you can continue to ride your vehicle.

If unstable engine operation occurs even if sufficient fuel is available, have your vehicle inspected by your dealer as soon as possible.

Information

| | |
|--|--------|
| Service Diagnostic Recorders..... | P. 139 |
| Keys..... | P. 139 |
| Instruments, Controls, & Other Features... | P. 143 |
| Caring for Your Vehicle..... | P. 143 |
| Storing Your Vehicle..... | P. 146 |
| Transporting Your Vehicle | P. 147 |
| You & the Environment | P. 148 |
| Serial Numbers | P. 149 |
| Fuels Containing Alcohol | P. 150 |
| Catalytic Converter | P. 151 |

Service Diagnostic Recorders

Your vehicle is equipped with service-related devices that record information about powertrain performance and riding conditions. The data can be used to help technicians diagnose, repair and maintain the vehicle. This data may not be accessed by anyone else except as legally required or with the permission of the vehicle owner.

However this data may be accessed by Honda, its authorised dealers and authorised repairers, employees, representatives and contractors only for the purpose of the technical diagnosis, research and development of the vehicle.

Keys

Emergency Key

The emergency key is used for an emergency.

- To unlock the seat. ➤ P. 127
- To unlock the ignition switch. ➤ P. 129

Do not store the emergency key in any compartment.

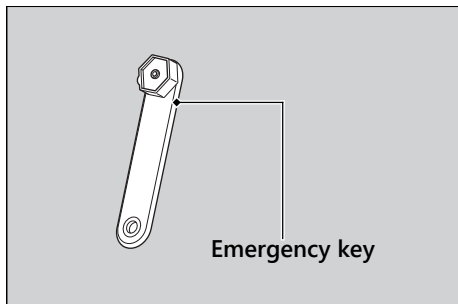

Honda SMART Key

Carrying the Honda SMART Key allows you to perform the following operations:

- Locking or unlocking the ignition switch
- Releasing the seat lock
- Opening the fuel lid.
- Locking or unlocking the steering

The ID number of the Honda SMART Key is on the ID tag. You can also unlock the ignition switch by inputting the ID number.

Always carry both the emergency key and ID tag, but separate from the Honda SMART Key, to avoid losing all of them at the same time.

Also store a copy of your ID number in a safe place other than your vehicle.

The Honda SMART Key contains electronic circuits. If the circuits are damaged, the Honda SMART Key will not allow you to perform any operations.

- Do not drop the Honda SMART Key or set heavy objects on them.
- Protect the Honda SMART Key from direct sunlight, high temperature, and high humidity.
- Do not scratch or puncture.
- Do not store near any magnetized products such as a magnetized key chain.
- Always keep the Honda SMART Key away from electric appliances such as a TV, radio, PC or low-frequency massage device.

- Keep the Honda SMART Key away from liquids. If it gets wet, dry it immediately with a soft cloth.
- Keep the Honda SMART Key away from the vehicle while washing the vehicle.
- Do not burn.
- Do not wash in the ultrasonic cleaner.
- If fuel, wax, or grease adhere to the Honda SMART Key, wipe it off immediately to avoid cracking or warping.
- Do not disassemble the Honda SMART Key other than when changing a battery. Only the cover of the Honda SMART Key can be disassembled. Do not disassemble other parts.
- Do not lose your Honda SMART Key. If you lose it, you will need to register a new Honda SMART Key. See your dealer with your emergency key and ID tag for registration.

The battery in the Honda SMART Key system normally lasts about 2 years.

Do not keep mobile phones or other radio transmitting devices in any compartment. The radio frequency from the devices will interrupt the Honda SMART Key system.

To get an additional Honda SMART Key, take the Honda SMART Key and the vehicle to your dealer.

Keys

EU Directive

This Honda SMART Key system complies with the RE (Radio Equipment) Directive (2014/53/EU).



The declaration of conformity to RE Directive is provided to the owner at the time of purchase. The declaration of conformity should be kept at a safe place. When the declaration of conformity is lost or is not provided, contact your dealer.

South Africa only



Singapore only



Morocco only

AGREE PAR L'ANRT MAROC

Numéro d'agrément : MR 6164 ANRT 2011

Date d'agrément : 04/04/2011

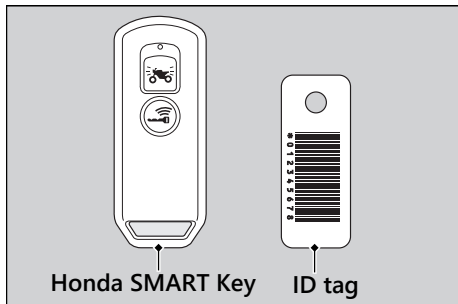

Instruments, Controls, & Other Features

Ignition Switch

Leaving the ignition switch in the **I** (On) position with the engine stopped will drain the battery.

Do not turn the ignition switch while riding.

Odometer

The display locks at 999,999 when the read-out exceeds 999,999.

Tripmeter

The tripmeters return to 0.0 when each read-out exceeds 9,999.9.

Document Bag

The owner's manual, registration, and insurance information can be stored in the plastic document bag in the centre compartment.

Caring for Your Vehicle

Frequent cleaning and polishing is important to ensure the life of your Honda. A clean vehicle makes it easier to spot potential problems. In particular, seawater and salts used to prevent ice on roads promote the formation of corrosion. Always wash your vehicle thoroughly after riding on coastal or treated roads.

Washing

Allow the engine, muffler, brakes, and other high-temperature parts to cool before washing.

1. Rinse your vehicle thoroughly using a low pressure garden hose to remove loose dirt.
2. If necessary, use a sponge or a soft towel with mild cleaner to remove road grime.
 - ▶ Clean the headlight lens, panels, and other plastic components with extra care to avoid scratching them. Avoid directing water into the air cleaner, muffler, and electrical parts.

Caring for Your Vehicle

3. Thoroughly rinse your vehicle with plenty of clean water and dry with a soft, clean cloth.
4. After the vehicle dries, lubricate any moving parts.
 - ▶ Make sure that no lubricant spills onto the brakes or tyres. Brake discs, pads, drum or shoes contaminated with oil will suffer greatly reduced braking effectiveness and can lead to a crash.
5. Apply a coat of wax to prevent corrosion.
 - ▶ Avoid products that contain harsh detergents or chemical solvents. These can damage the metal, paint, and plastic on your vehicle.
Keep the wax clear of the tyres and brakes.
 - ▶ If your vehicle has any mat painted parts, do not apply a coat of wax to the mat painted surface.

Washing Precautions

Follow these guidelines when washing:

- Do not use high-pressure washers:
 - ▶ High-pressure water cleaners can damage moving parts and electrical parts, rendering them inoperable.
 - ▶ Water in the air intake can be drawn into the throttle body and/or enter the air cleaner.
- Do not direct water at the muffler:
 - ▶ Water in the muffler can prevent starting and causes rust in the muffler.
- Dry the brakes:
 - ▶ Water adversely affects braking effectiveness. After washing, apply the brakes intermittently at low speed to help dry them.
- Do not direct water under the seat:
 - ▶ Water in the under seat compartment can damage your documents and other belongings.

- Do not direct water at the air cleaner:
 - ▶ Water in the air cleaner can prevent the engine from starting.
- Do not direct water near the headlight:
 - ▶ The headlight's inside lens may fog temporarily after washing or while riding in the rain. This does not impact the headlight function.
However, if you see a large amount of water or ice accumulated inside the lens(es), have your vehicle inspected by your dealer.
- Do not use wax or polishing compounds on mat painted surface:
 - ▶ Use a soft cloth or sponge, plenty of water, and a mild detergent to clean mat painted surfaces. Dry with a soft clean cloth.

Aluminium Components

Aluminium will corrode from contact with dirt, mud, or road salt. Clean aluminium parts regularly and follow these guidelines to avoid scratches:

- Do not use stiff brushes, steel wool, or cleaners containing abrasives.
- Avoid riding over or scraping against curbs.

Panels

Follow these guidelines to prevent scratches and blemishes:

- Wash gently using a soft sponge and plenty of water.
- To remove stubborn stains, use diluted detergent and rinse thoroughly with plenty of water.
- Avoid getting petrol, brake fluid, or detergents on the instruments, panels, or headlight.

Exhaust Pipe and Muffler

When the exhaust pipe and muffler are painted, do not use a commercially available abrasive kitchen cleaning compound. Use a neutral detergent to clean the painted surface on the exhaust pipe and muffler. If you are not sure if your exhaust pipe and muffler are painted, contact your dealer.

Storing Your Vehicle

If you store your vehicle outdoors, you should consider using a full-body cover.

If you won't be riding for an extended period, follow these guidelines:

- Wash your vehicle and wax all painted surfaces (except mat painted surfaces). Coat chrome pieces with rust-inhibiting oil.
- Place your vehicle on its centre stand and position a block so that both tyres are off the ground.
- After rain, remove the body cover and allow the vehicle to dry.
- Remove the battery (➤ P. 91) to prevent discharge. Fully charge the battery and then place it in a shaded, well-ventilated area.
 - ▶ If you leave the battery in place, disconnect the negative ⊖ terminal to prevent discharge.

After removing your vehicle from storage, inspect all maintenance items required by the Maintenance Schedule.

Transporting Your Vehicle

If your vehicle needs to be transported, it should be carried on a motorcycle trailer or a flatbed truck or trailer that has a loading ramp or lifting platform, and motorcycle tie-down straps. Never try to tow your vehicle with a wheel or wheels on the ground.

NOTICE

Towing your vehicle can cause serious damage to the transmission.

You & the Environment

Owning and riding a vehicle can be enjoyable, but you must do your part to protect the environment.

Choose Sensible Cleaners

Use a biodegradable detergent when you wash your vehicle. Avoid aerosol spray cleaners that contain chlorofluorocarbons (CFCs) which damage the atmosphere's protective ozone layer.

Recycle Wastes

Put oil and other toxic wastes in approved containers and take them to a recycling centre. Call your local or state office of public works or environmental services to find a recycling centre in your area, and to get instructions on how to dispose of non-recyclable wastes. Do not place used engine oil in the trash, or pour it down a drain or on the ground. Used oil, petrol, coolant, and cleaning solvents contain poisons that can hurt refuse workers and contaminate drinking water, lakes, rivers, and oceans.

Serial Numbers

The frame and engine serial numbers uniquely identify your vehicle and are required in order to register your vehicle. They may also be required when ordering replacement parts. You should record these numbers and keep them in a safe place.

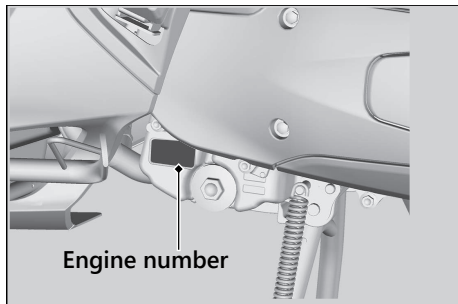
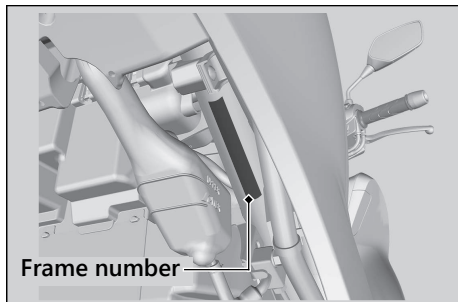

Fuels Containing Alcohol

Some conventional fuels blended with alcohol are available in some locales to help reduce emissions to meet clean air standards. If you plan to use blended fuel, check that it is unleaded and meets the minimum octane rating requirement.

The following fuel blends can be used in your vehicle:

- Ethanol (ethyl alcohol) up to 10% by volume.
 - ▶ Petrol containing ethanol may be marketed under the name Gasohol.

The use of petrol containing more than 10% ethanol may:

- Damage the painting of the fuel tank.
- Damage the rubber tubes of the fuel line.
- Cause corrosion of the fuel tank.
- Cause poor drivability.

NOTICE

Use of blended fuels containing higher than approved percentages can damage metal, rubber, plastic parts of your fuel system.

If you notice any undesirable operating symptoms or performance problems, try a different brand of petrol.

Catalytic Converter

SH125AD

This vehicle is equipped with a three-way catalytic converter. The catalytic converter contains precious metals that serve as catalysts in high temperature chemical reactions that convert hydrocarbons (HC), carbon monoxide (CO), and oxides of nitrogen (NO_x) in the exhaust gasses into safe compounds.

SH150AD

This vehicle is equipped with two three-way catalytic converters. Each catalytic converter contains precious metals that serve as catalysts in high temperature chemical reactions that convert hydrocarbons (HC), carbon monoxide (CO), and oxides of nitrogen (NO_x) in the exhaust gasses into safe compounds.

A defective catalytic converter contributes to air pollution and can impair your engine's performance. A replacement unit must be an original Honda part or equivalent.

SH125AD

Follow these guidelines to protect your vehicle's catalytic converter.

- Always use unleaded petrol. Leaded petrol will damage the catalytic converter.
- Keep the engine in good running condition.
- Have your vehicle serviced if your engine is misfiring, backfiring, stalling, or otherwise not running properly, stop riding and turn off the engine.

SH150AD

Follow these guidelines to protect your vehicle's catalytic converters.

- Always use unleaded petrol. Leaded petrol will damage the catalytic converters.
- Keep the engine in good running condition.
- Have your vehicle serviced if your engine is misfiring, backfiring, stalling, or otherwise not running properly, stop riding and turn off the engine.

Specifications

■ Main Components

| | |
|---------------------------------------|---------------------------|
| Overall length | 2,090 mm (82.3 in) |
| Overall width | 730 mm (28.7 in) |
| Overall height | 1,130 mm (44.5 in) |
| Wheelbase | 1,350 mm (53.1 in) |
| Minimum ground clearance | 145 mm (5.7 in) |
| Caster angle | 26° 00' |
| Trail | 86 mm (3.4 in) |
| Curb weight | II ED, III ED type |
| | 138 kg (304 lb) |
| | Except II ED, III ED type |
| Maximum weight capacity ^{*1} | 137 kg (302 lb) |
| | 180 kg (397 lb) |
| Maximum luggage weight | Centre compartment |
| | 10 kg (22 lb) |
| | Shopping hook |
| | 1.5 kg (3.3 lb) |
| | Rear carrier |
| | 3 kg (6.6 lb) |
| Passenger capacity | Rider and 1 passenger |
| Minimum turning radius | 2.00 m (6.6 ft) |

*1 : Including rider, passenger, all luggage, and accessories.

| | | |
|-------------------------|--|---------------------------------|
| Displacement | SH125AD | 125 cm ³ (7.6 cu-in) |
| | SH150AD | 157 cm ³ (9.6 cu-in) |
| Bore x stroke | SH125AD | 53.5 x 55.5 mm (2.11 x 2.19 in) |
| | SH150AD | 60.0 x 55.5 mm (2.36 x 2.19 in) |
| Compression ratio | SH125AD | 11.5:1 |
| | SH150AD | 12.0:1 |
| Fuel | Unleaded petrol Recommended: 95 RON or higher | |
| Fuel containing alcohol | ETHANOL up to 10 % by volume | |
| Tank capacity | 7.0 L (1.85 US gal, 1.54 Imp gal) | |
| Battery | YTZ8V | |
| | 12 V-7.0 Ah (10 HR) / 7.4 Ah (20 HR) | |
| Primary reduction | V-Matic (2.68:1 ~ 0.82:1) | |
| Final reduction | SH125AD | 11.423 |
| | SH150AD | 10.552 |

■ Service Data

| | | |
|--|-------------------------------|---|
| Tyre size | Front | 100/80-16M/C 50P |
| | Rear | 120/80-16M/C 60P |
| Tyre type | Bias-ply, tubeless | |
| Recommended Tyre | Front | IRC SS-530F |
| | | MICHELIN CITY GRIP |
| | Rear | IRC SS-530R |
| | | MICHELIN CITY GRIP |
| | Normal | Permitted |
| Tyre category of use *1 | Special | Not Permitted |
| | Snow | Not Permitted |
| | Moped | Not Permitted |
| Tyre air pressure (Driver only) | Front | 200 kPa (2.00 kgf/cm ² , 29 psi) |
| | Rear | 225 kPa (2.25 kgf/cm ² , 33 psi) |
| Tyre air pressure (Driver and passenger) | Front | 200 kPa (2.00 kgf/cm ² , 29 psi) |
| | Rear | 225 kPa (2.25 kgf/cm ² , 33 psi) |
| Minimum tread depth (SH150AD only) | Front | 1.5 mm (0.06 in) |
| | Rear | 2.0 mm (0.08 in) |
| Spark plug | (standard) | LMAR8L-9 (NGK) |
| Spark plug gap | 0.8 - 0.9 mm (0.03 - 0.04 in) | |
| Idle speed | 1,700 ± 100 rpm | |

| | | |
|---------------------------|---|----------------------------------|
| Recommended engine oil | Honda 4-stroke motorcycle oil API Service Classification SG or higher, excluding oils marked as "Energy Conserving" or "Resource Conserving," "SAE 10W-30, JASO T 903 standard MB | |
| Engine oil capacity | After draining | 0.8 L (0.8 US qt, 0.7 Imp qt) |
| | After draining & cleaning strainer screen | 0.9 L (1.0 US qt, 0.8 Imp qt) |
| Transmission oil capacity | After draining | 0.12 L (0.13 US qt, 0.11 Imp qt) |
| | After disassembly | 0.14 L (0.15 US qt, 0.12 Imp qt) |
| Recommended brake fluid | Honda DOT 3 or DOT 4 Brake Fluid | |
| Cooling system capacity | 0.47 L (0.50 US qt, 0.41 Imp qt) | |
| Recommended coolant | Pro Honda HP Coolant | |

*1: EU regulation

Specifications

■ Bulbs

| | |
|----------------------|-----|
| Headlight | LED |
| Brakelight/Taillight | LED |
| Front turn signal | LED |
| Rear turn signal | LED |
| License plate light | LED |
| Position light | LED |

■ Fuses

| | |
|------------|-------------------------|
| Main fuse | 20 A |
| Other fuse | 30 A, 15 A, 10 A, 7.5 A |

■ Torque Specifications

| | |
|-----------------------|-------------------------------|
| Oil plug | 20 N·m (2.0 kgf·m, 15 lbf·ft) |
| Engine oil drain bolt | 24 N·m (2.4 kgf·m, 18 lbf·ft) |

- A**
- ABS (Anti-lock Brake System)..... 12
 - ABS (Anti-lock Brake System)
 - Indicator 41, 118
 - Accessories 16
 - Answer Back System 53
 - Available Driving Distance 23, 26
 - Average Fuel Mileage..... 23, 27
- B**
- Battery 81, 91
 - Battery Voltage Meter..... 23, 28
 - Brakes
 - Fluid..... 85, 105
 - Pad Wear 106
 - Braking 11
 - Bulb
 - Brakelight/Taillight..... 135
 - Front Turn Signal 134
 - Headlight 134
 - License Plate Light..... 135
 - Position Light 134
 - Rear Turn Signal..... 135
- C**
- Caring for Your Vehicle..... 143
 - Catalytic Converter..... 151
 - Centre Compartment..... 71
 - Clock..... 23, 33
 - Compartment
 - Document Bag 143
 - Owner's Manual..... 143
 - Coolant..... 102
 - Crankcase Breather 86, 109
 - Current Fuel Mileage..... 23, 25
- D**
- Digital Clock Adjustment..... 33
 - Document Bag 72, 143
- E**
- Electrical Trouble 133
 - Emergency
 - Emergency Key..... 139
 - Unlock the Ignition Switch..... 129
 - Unlock the Seat..... 127

- Engine**
 Number 149
 Oil 84, 98
 Oil Strainer Screen 99
 Overheats 116
 Starting 59
- Environment** 148
- F**
- Flooded Engine** 59
- Frame Number** 149
- Fuel**
 Gauge 23, 28
 Recommended 64, 152
 Remaining 28
 Tank Capacity 64, 152
- Fuels Containing Alcohol** 150
- Fuses** 83, 136
- G**
- Gasohol** 150
- H**
- Headlight Aim** 110
- Headlight Dimmer Switch** 42
- Helmet Holder** 70
- High Coolant Temperature Indicator** 40
- Honda Selectable Torque Control** 15, 58
- Honda SMART Key** 140
- Honda SMART Key Battery** 112
- Honda SMART Key Indicator** 40, 120
- Honda SMART Key System** 45
- Horn Button** 42
- I**
- Idling Stop Indicator** 40
- Idling Stop Switch** 42
- Idling Stop System** 55
- Ignition Cut-off System**
 Side Stand 107
- Ignition Switch** 43, 143
- Image Labels** 6
- Indicators** 40
- INFO A button** 22, 42
- INFO B button** 22, 42
- Instruments** 22

| | | |
|---|-------------|--|
| K | | |
| Key | | |
| Emergency Key..... | 139 | |
| Honda SMART Key..... | 140 | |
| L | | |
| Labels | 6 | |
| Load Limits | 17 | |
| Loading Guidelines | 17 | |
| M | | |
| Maintenance | | |
| Fundamentals..... | 79 | |
| Importance..... | 75 | |
| Safety..... | 75 | |
| Schedule..... | 76 | |
| Maintenance Indicator | 23, 31 | |
| Maximum Luggage Weight | 9, 152 | |
| Maximum Weight Limit | 17, 152 | |
| Modifications | 16 | |
| O | | |
| Odometer | 23, 25, 143 | |
| Oil | | |
| Engine..... | 84, 98 | |
| Oil Change Indicator | 23, 30 | |
| Overheating | 116 | |
| P | | |
| Parking | 12 | |
| Parts Location | 20 | |
| Passing Light Control Switch | 42 | |
| Petrol | 14, 64, 152 | |
| PGM-FI (Programmed Fuel Injection) | | |
| Malfunction Indicator Lamp (MIL).... | 40, 117 | |
| Protective Apparel | 10 | |
| R | | |
| Rear Carrier | 73 | |
| Rear Suspension | 111 | |
| Recommended | | |
| Coolant..... | 85, 153 | |
| Fuel..... | 64, 152 | |
| Oil..... | 84 | |
| Refuelling | 64 | |

| | |
|--|-------------|
| Removal | |
| Battery..... | 91 |
| Battery Cover | 93 |
| Clip..... | 94 |
| Maintenance Lid..... | 95 |
| Repair Kit | 132 |
| Riding Precautions | 11 |
| S | |
| Safety Precautions | 10 |
| Seat | 69 |
| Serial Numbers | 149 |
| Shopping Hook | 73 |
| Side Stand | 107 |
| Side Stand Ignition Cut-off System | 59, 107 |
| Spark Plug | 96 |
| Specifications | 152 |
| Speedometer | 23 |
| Start Button | 42 |
| Starting the Engine | 59 |
| Steering Lock | 44 |
| Storage | |
| Centre Compartment..... | 71 |
| Document Bag..... | 72 |
| Equipment | 69 |
| Owner's Manual | 72 |
| Rear Carrier | 73 |
| Shopping Hook | 73 |
| Tool Kit..... | 72 |
| Storing | 146 |
| Switches | 42 |
| T | |
| Throttle | 108 |
| Tool | 90 |
| Tool Kit | 72, 90 |
| Torque Control Indicator | 41, 119 |
| Torque Control mode display | 23, 28 |
| Torque Control OFF Indicator | 41 |
| Transporting | 147 |
| Tripmeter | 23, 26, 143 |
| Troubleshooting | 114 |
| Turn Signal Indicators | 41 |
| Turn Signal Switch | 42 |
| Tyres | |
| Air Pressure..... | 9, 86, 153 |
| Puncture..... | 132 |
| Replacing | 86 |

U

USB Socket 67

W

Warning Indicators On or Flashing 117

Washing Your Vehicle 143

Weight Limit..... 17, 152

HONDA
The Power of Dreams

SH125i/SH150i



32K0RA00
00X32-K0R-A000

XXX.XXXX.XX.L
PRINTED IN XXXXX

