

HONDA

ATV & UTV RANGE





DEPENDABLE. DAWN 'TIL DUSK, DAY AFTER DAY.

Honda Engineering Excellence	04
Honda Warranty	05
Choosing The Right Model	06
Authorised Honda Dealers	08
EASI Training	09
UTV RANGE	10
Pioneer 520 4wd	12
Pioneer 700-2 4wd	14
Pioneer 700-4 4wd	16
Genuine Honda UTV Accessories	18
ATV RANGE	24
Fourtrax 420 4wd	26
Fourtrax 420 DCT 4wd	28
Foreman 520 4wd	30
Foreman 520 DCT 4wd	32
Model Specifications	34
Technology Glossary	38
Useful Honda Technology	39



ENGINEERING FOR *Life*

ENGINEERED WITH EXCELLENCE



RENOWNED FOR RELIABILITY



Built better to last longer

So, what makes Honda ATVs and UTVs so good?

Near the small town of Timmonsville, USA, is Honda of South Carolina Manufacturing Inc (HSC), one of our 14 specialist factories located in North America. Over 650 Honda Associates manufacture and assemble our ATV and UTV range at the 615-acre site, with many employees using a Honda for both work and leisure – making the product not just a job, but also a way of life.

Uniquely, all research and product development takes place at either HSC, or at the Honda Car R&D facility in Ohio, where using computer aided modelling and advanced car design software, our engineers have been able to test and improve model features such as rack weights, ride dynamics and ergonomics – producing a lighter, stronger product.

All frames, bodywork, fuel tanks and engine castings are fabricated on-site, and with up to 68 model variations constructed at HSC, nearly every model that comes off the production line differs from the one before. But for each model, the emphasis remains the same, it has to offer durability, quality and reliability with the over-arching principle of safety for all those involved. Our vision has always been to be a company that society wants to exist, even at manufacturing level. It's what drives us to remain a leader in the industry, whilst having a positive impact both globally and locally, from South Carolina to South Wales and everywhere else Hondas are relied upon day in, day out.



Quality you can count on

Our ATV and UTV range are relied upon daily for an almost infinite variety of tasks, by all kinds of users. Like you, they demand complete reliability, unrivalled performance and a solid build. Which is why we offer a 2 year manufacturer's warranty* with all of our ATV and UTV models as standard.

Whether you're using it for farming, gamekeeping, forestry, equestrian or snowclearing; your Honda will quickly become an essential part of your daily routine. You'll rely on it in all weathers, on all terrain and for an amazingly wide range of jobs.

So a problem with your new ATV or UTV is the last thing you'll want, but with Honda's reputation for reliability, it's also the last thing you can expect.

*Subject to following the service schedule, 2 year warranty applies to domestic and commercial use. 3 month warranty for competitive and race use.

CHOOSING YOUR SUSPENSION



Each ATV model in our range features independent front suspension, but when it comes to the rear suspension, several of our models offer two different options to choose from. It's not a matter of one being better than the other, but one may suit your needs a little more than the other.

Swingarm Rear Suspension

An excellent choice for riders looking for a hard-working ATV with plenty of towing capability. A solid locked rear-axle with a trailer hitch bolted directly to the axle housing, means the swingarm design is simple and durable, and has been a proven mainstay of Honda ATVs over the decades.

- **Bolts direct to axle housing** | Less body squat when towing
- **Rigid locked rear axle** | Solid tow hitch capability

Independent Rear Suspension (IRS)

A smart choice for ATV riders who spend long days in the saddle, especially on tough or unpredictable terrain. Each wheel moves independently, so you get a smoother ride. As an added bonus each tyre remains in optimal contact with the ground, so in certain circumstances you can get superior traction from the rear wheels.

- **Longer travel shock absorption** | More comfort & ground clearance
- **Improved tow capacity** | Pull up to an impressive 600kg*
- **Note:** IRS is standard on all UTV models.

*Tow capacity varies by model, please refer to the specification on page 34-37. Tow ball is optional accessory.

CHOOSING YOUR TRANSMISSION



There are four different transmission options to choose from within our ATV range, as well as Power Steering on certain models. All of which have their specific benefits depending on how, and where, you will mostly be using your ATV.



Manual

With manual shift gear changes and an automatic clutch mechanism, nothing can match a traditional manual transmission ATV in terms of simplicity. So it makes this an ideal transmission for riders who use their ATVs day in, day out on a variety of tasks.



Electric Shift Program (ESP)

With its automatic clutch, ESP lets you quickly and easily shift between gears with a pair of handlebar mounted buttons.



Automatic (AT)

Standard on UTV models – This effortless three-speed drive system is based on the technology in modern automatic cars, providing seamless acceleration on any terrain.



Dual Clutch Transmission (DCT)

Using two clutches, DCT models combine the strength of a manual transmission with the convenience of an automatic. The smooth shifts, excellent control and true engine braking it provides can be a real advantage in technical conditions.



Power Steering (PS)

Optimised to reduce steering effort and kickback through the handlebar, PS offers added comfort and control – ideal for those who spend long hours in the saddle.

HONDA AUTHORISED DEALERS

COMMITTED TO RIDER SAFETY



Trust the true ATV & UTV experts

You deserve complete confidence that you've made the right choice, long after you've made the purchase. That's why we appoint our Honda Authorised Dealers with as much care as we build into our products.

£ Sales

Our Authorised Dealers not only feature a comprehensive display of Honda products to see and touch, but they know our product range inside-out. Every one follows an extensive Honda training programme with regular refresher courses – so you can trust in their valuable advice and experience to help you choose the product that's just right for you.

🔧 Service

As well as offering the highest levels of after-sales service, our Authorised Dealers' factory trained technicians perform a full Pre-Delivery Inspection (PDI) on every machine, and are fully equipped to keep your product in peak condition with cost-effective servicing. Of course, you can also be assured that only high quality, genuine Honda parts are used, with access to our next day^{††} delivery service for fast and efficient turnaround.

★ Expertise

Our Authorised Dealers are true experts in their field, often with years of first-hand experience under their belt. In fact, their knowledge and experience plays an important role in making sure that our Research and Development team is given feedback from our customers, so we can ensure that new and improved models continue to meet your future needs too.



Complimentary Easi Rider Training

At Honda we take rider safety very seriously indeed. Which is why an EASI Rider Course[®] is included with every new Honda ATV or UTV at no cost.

Your Honda Authorised Dealer will register you for your course. It's worth it as it can qualify in risk assessments for PUWER or HSE requirements. For commercial users HSE risk assessments may require further training, such as through Lantra, or as part of your tractor loading / towing course.

To ensure you get the most from your Honda safely, we would encourage you to take approved training. Information on basic and advanced training courses is available from EASI.

Call 01273 494128 or visit www.quadsafety.org

Call **0345 200 8000[†]**
and we'll find your closest
Honda Authorised Dealer



ALL CHALLENGES OVERCOME

WITH A HONDA PIONEER





Small but mighty, with a slim profile allowing you and a passenger to go places other UTVs can't.



NEW 4WD



PIONEER 520

THE COMPACT UTV

Our NEW Pioneer 520 is powerful, versatile and durable. Strong enough to tackle the toughest terrains, and compact enough to reach the tightest of locations.

With its powerful 518cc engine specially tuned for low-rpm torque, and its efficient five-speed automatic transmission – The Pioneer 520 delivers plenty of pulling power and traction. Its useful, tilting cargo bed with assist strut, allows you to carry and dump up to 204kg with ease. Its fully independent suspension provides a smooth and comfortable ride, even over rough terrain. But it's overall size is what makes it so versatile, at just 127cm wide it offers excellent manoeuvrability, allowing you and a passenger to reach places other UTVs can't – and weighing just 483Kg, it happens to be one of the lightest petrol UTVs on the market too.

Key specification features	
<ul style="list-style-type: none"> Fuel-injected 518cc OHV single-cylinder engine Ensures effortless all-weather starts and high-altitude operation 	
<ul style="list-style-type: none"> 204kg cargo bed capacity With a tailgate that opens flat for easy loading, carrying and dumping 	
<ul style="list-style-type: none"> Impressive 454kg towing capacity Powerful despite it's compact size 	
<ul style="list-style-type: none"> Five-speed auto transmissions Switch with ease between manual paddle shift gears or auto transmission 	
<ul style="list-style-type: none"> Side by side seating A comfortable bench-style seat carries the rider and a passenger 	
<ul style="list-style-type: none"> Front opening doors allow for easy access for both rider and passenger 	

Pioneer 520	
	Traxlok® allows you to quickly switch between the 'go-anywhere' traction of 4wd and the increased manoeuvrability and lighter steering of 2wd.
	Independent Rear Suspension (IRS) for improved comfort, traction and load handling capability.

Accessories available from July 2021 [see page 18](#)

From windscreens to roofs, wing mirrors to wind deflectors, make your Pioneer 520 even more versatile with our range of Honda accessories.

Please speak to your local dealer for more information.





Carry a full bed of cargo and an extra pair of hands

4WD

Available in Green

PIONEER 700-2

THE VERSATILE WORKMATE



Our Pioneer 700-2 UTV is powerful, incredibly versatile and built to tackle the toughest jobs and cover the most demanding terrains.

Drawing upon all of our experience and expertise in designing class-leading ATVs; the Pioneer 700-2 can carry two people – perfect for those times when you need an extra pair of hands on the job. Its 675cc liquid-cooled engine is rubber mounted for less cabin vibration and fuel-injected for all-weather starts. Its tilting cargo bed can carry up to 386kg and its impressive 680kg tow capacity allows you to haul more, go further and get more done whilst offering all of the comfort, fuel-efficiency and build quality you would expect from a Honda.

Key specification features

- **Fuel-injected 675cc OHV single-cylinder engine**
For all-weather starts
- **Independent front & rear suspension**
For superior handling and comfort
- **Tilt bed with smart assist strut**
Unload the cargo bed with ease
- **Three-speed auto transmissions**
Provides true engine braking
- **680kg towing capacity**
Makes light work of pulling a heavy load
- **386kg cargo bed capacity**
Saving valuable time and effort

Pioneer 700-2

-  **Auto** Three speed automatic transmission gives seamless acceleration over any terrain.
-  **Differential Lock** provides additional traction in slippery conditions, with the push of a lever.
-  **Independent Rear Suspension (IRS)** for improved comfort, traction and load handling capability.

Accessories available

see page 20

From windscreens to roofs, wing mirrors to wind deflectors, make your Pioneer 700 even more versatile with our range of Honda accessories.





Rear seats collapse independently to provide a flexible cargo bed

4WD Available in Green



PIONEER 700-4



THE ULTIMATE TEAMWORKER

Built to get those really big jobs done, our Pioneer 700-4 UTV can carry up to four people thanks to its industry exclusive QuickFlip® seating system.

Featuring all of the clever innovation of our 700-2 model (see page 14), the versatile Pioneer 700-4 has the added ability to switch between carrying one passenger with full cargo bed capacity and tipping function – to two or three passengers, depending on the task at hand. Its innovative and durable QuickFlip® rear seats fold flat into the cargo bed independently and pop-up in an instant whenever you need them.

Key specification features	
• QuickFlip® Seating	Flip with ease between two, three or four seats
• Fuel-injected 675cc OHV single-cylinder engine	For all-weather starts
• Independent front & rear suspension	For superior handling and comfort
• Tilt bed with smart assist strut	Unload the cargo bed with ease
• Three-speed auto transmissions	Provides true engine braking
• 680kg towing capacity	Makes light work of pulling a heavy load
• 386kg cargo bed capacity	Saving valuable time and effort

Pioneer 700-4	
	Three speed automatic transmission gives seamless acceleration over any terrain.
	Differential Lock provides additional traction in slippery conditions, with the push of a lever.
	Independent Rear Suspension (IRS) for improved comfort, traction and load handling capability.

Quick Flip® Seating		
1. Full Cargo Bed	2. One Rear Seat	3. Two Rear Seats
		



GENUINE HONDA UTV ACCESSORIES



The Honda Pioneer. As versatile as you are.

The Pioneer is the perfect vehicle for working the farm or for going hunting. With so many ways to customise it, the Pioneer is ready to go – your way.

For more information on the full range of Genuine Honda Pioneer Accessories, please see the full Pioneer Accessory Brochure and contact your Authorised ATV Honda dealer.

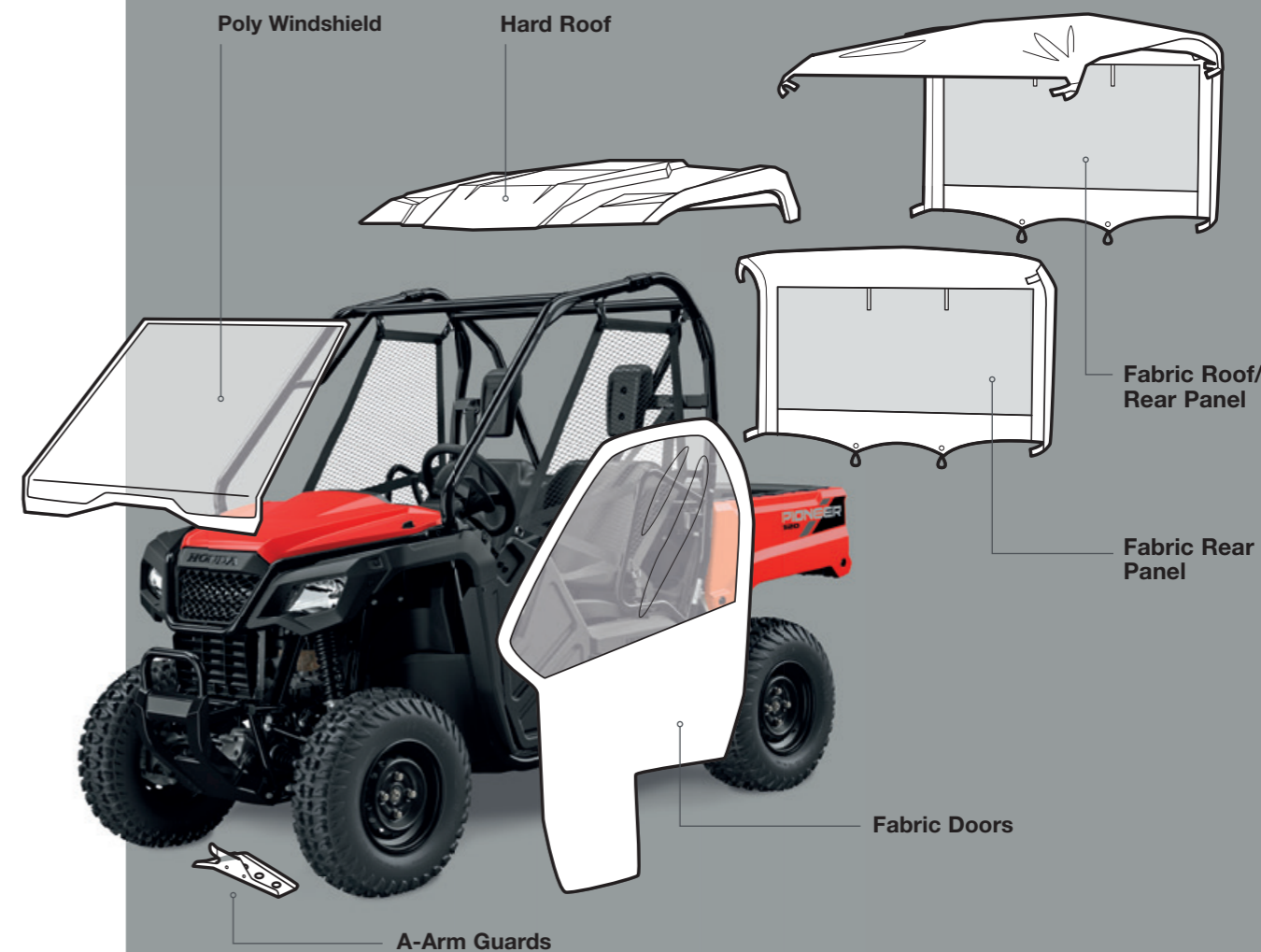

From fabric doors to a hard roof – customise your Pioneer 520 to suit your own needs, with these Genuine Honda UTV Accessories.

 Pioneer 520
Two seats

PIONEER 520	
Genuine Honda Accessory	Part numbers:
Front A Arm Guards	08P70-HL5-A00
Rear A Arm Guards	08P71-HL5-A00
Skid Plate	08P70-HL5-A40
Drawbar	08L76-HL5-A00
Hard Roof	08R70-HL5-A01
Polycarbonate Windscreen	0SR73-HL5-100
Wind deflector	0SR73-HL5-101B
Fabric Doors	0SR90-HL5-A01B
Fabric Rear Panel	0SR95-HL5-A01
Fabric roof/Rear Panel	0SR85-HL5-A01B
Mirror L/R Kit	0SV05-HL5-100

Accessories will be available on a staggered basis between April - July. Please speak to your authorised Honda dealer to confirm exact availability



GENUINE HONDA UTV ACCESSORIES

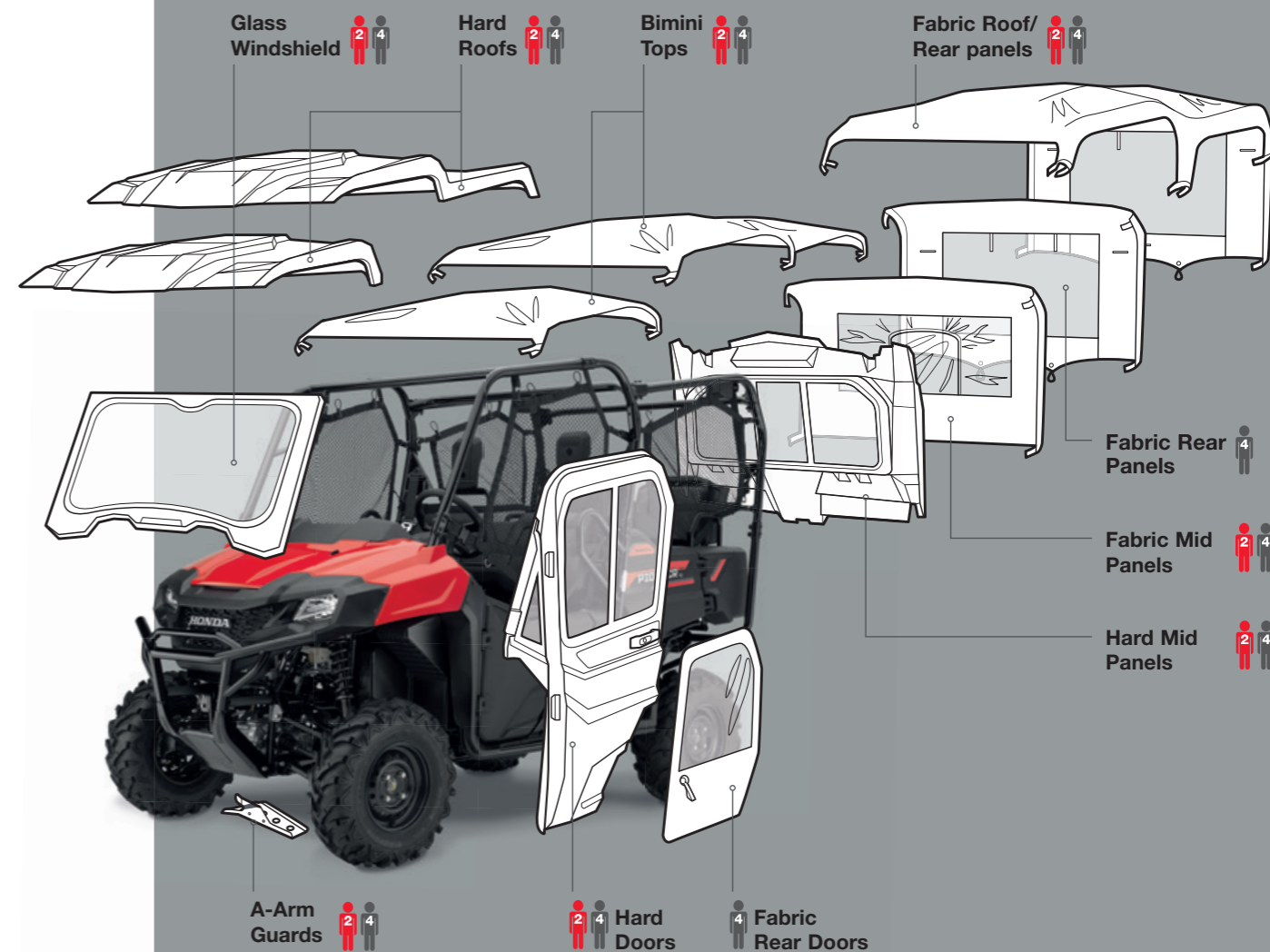



Body panel kits

Make your UTV more discreet against the landscape with green body panels, available for selected models. Consult your Honda ATV Authorised Dealer for details and availability.

Green Body Panel Kits:	Part numbers:
Pioneer 700-2 (two seats)	01150-HL3-22GN
Pioneer 700-4 (four seats)	01150-HL3-04GN

Honda Signature Cab Kits

-  Pioneer 700-2
Two seats
-  Pioneer 700-4
Four seats

Get the most out of your Pioneer, make it even more versatile and tailored to your needs with a Genuine Honda UTV Signature Full Cab, or Half Cab Kit.

Enjoy the benefits of exact factory specifications, ensuring a precise fit, superior function and integrated design; all specifically built and tested to the same rigorous standards as our ATVs. The Genuine Signature Range of accessories is modular. You can select a roof and screen, or make a fully enclosed cab with doors, for either a 2 or 4 person Pioneer. See next page for a breakdown of what is included in our Signature range, Half Cab and Full Cab kits.

For more information on the full range of Genuine Honda Pioneer Accessories, please see the full Pioneer Accessory Brochure and contact your Authorised ATV Honda dealer.



SIGNATURE CAB KITS PIONEER 700-2

SIGNATURE CAB KITS PIONEER 700-4



PIONEER 700-2 HALF CAB KIT	OSR75-HL3-0002P
Half cab kit consists of the following:	Part numbers:
Hard Roof 2P	OSR85-HL3-101
Windscreen	OSU95-HL3-105
Hard Rear Panel	OSU95-HL3-102A
Wiper/Washer Kit	OUE12-HL3-202



PIONEER 700-2 FULL CAB KIT	OSR85-HL3-0002P
Full cab kit consists of the following:	Part numbers:
Hard Roof 2P	OSR85-HL3-101
Windscreen	OSU95-HL3-105
Hard Rear Panel	OSU95-HL3-102A
Wiper/Washer Kit	OUE12-HL3-202
Hard Front Doors	OSU95-HL3-104A



PIONEER 700-4 HALF CAB KIT	OSR75-HL3-0004P
Half cab kit consists of the following:	Part numbers:
Hard Roof (Long)	OSR85-HL3-100
Windscreen	OSU95-HL3-105
Hard Rear Panel (sits behind front seats)	OSU95-HL3-104C
Wiper/Washer Kit	OUE12-HL3-202



PIONEER 700-4 FULL CAB KIT	OSR85-HL3-0004P
Full cab kit consists of the following:	Part numbers:
Hard Roof (Long)	OSR85-HL3-100
Windscreen	OSU95-HL3-105
Hard Rear Panel (sits behind front seats)	OSU95-HL3-104C
Wiper/Washer Kit	OUE12-HL3-202
Hard Front Doors	OSU95-HL3-104A
Fabric Rear Doors	OSR91-HL3-211B
Fabric Rear Panel	OSR95-HL3-211B

ALL GROUND COVERED

— WITH A HONDA ATV



A true, mid-size all-rounder with class-leading power and efficiency

NEW 4WD Available in Green*

FOURTRAX 420

THE UK'S BEST SELLING ATV

Powerful, efficient and compact, with excellent agility and towing capability. Fourtrax 4wd models are perfectly engineered to tackle the most demanding of conditions.

A 420cc fuel injected, liquid-cooled, longitudinal mounted engine, delivers both economy and performance. Optimised with Computer Aided Design (CAD) to deliver best-in-class handling and all day comfort – the versatile Fourtrax 4wd really sets the standard, making daily tasks both easier and more enjoyable. Its rugged utility styling and tough double-cradle chassis offer exceptional durability and handling. Its multi-function LCD display provides the driver with key information at a glance, whilst the adjustable pre-load front and rear suspension lets you tailor the ride to the terrain and conditions.

- NEW Features**
- **Forward/Reverse Skip Switch (DCT & ES)**
Bypass neutral when reversing
 - **Redesigned front and rear racks**
Providing a better surface area
 - **1.9L water resistant utility box**
Providing useful storage
 - **New protecting guards**
For the lower suspension & driveshaft

- Fourtrax 420 4wd.** All models have the below features:
- **2/4^{WD}** Traxlok® allows you to quickly switch between the 'go-anywhere' traction of 4wd and the increased manoeuvrability and lighter steering of 2wd.
 - **Manual** 5-speed transmission with automatic clutch and low-rpm engagement point for excellent control and towing capability.
 - **AP Suretrac™** torque-sensitive limited-slip differential for extra grip in slippery conditions.
- Fourtrax 420 PS 4wd.** As Fourtrax 420 (above)+
- **Power Steering (PS)** to greatly reduce steering effort and kickback through the handlebar.
- Fourtrax 420 ES 4wd.** As Fourtrax 420+
- **Handlebar mounted Electric Shift Program (ESP)** for quick push-button gear selection.





Enjoy fast, smooth gear changes with Dual Clutch Transmission

NEW 4WD

FOURTRAX 420 DCT

THE ADVANCED MID-SIZE ATV

For simple usability and a rewarding ride, the Fourtrax DCT 4wd models really set the standard with greater fuel efficiency and automatic shifting.

With new levels of rider centred technology, and a powerful yet frugal fuel injected, liquid cooled 420cc OHV engine – the Fourtrax 420 DCT offers outstanding levels of performance, handling and durability. Yet it also ensures exceptional economy, responsive power and easy starts that you can count on in any weather. Our fuel efficient, advanced **Dual Clutch Transmission (DCT)** has been tried and tested on Honda's market leading motorcycles for many years, allowing riders to quickly shift between gears with smooth ESP control, or opt for an auto-shifting mode. Either way, the Fourtrax 420 DCT delivers fast, efficient transmission to cover even the most challenging land with ease. An axle mounted heavy duty trailer hitch provides an impressive 385kg towing capacity*.

NEW Features

- **Forward/Reverse Skip Switch (DCT & ES)**
Bypass neutral when reversing
- **Redesigned front and rear racks**
Providing a better surface area
- **1.9L water resistant utility box**
Providing useful storage
- **New shift map**
Monitors RPM in real time shifting
- **Manual override**
Override for added control
- **New protecting guards**
For the lower suspension & driveshaft

*Available on TRX420FA2 model only



Fourtrax 420 DCT PS 4wd.

2/4 Traxlok® allows you to quickly switch between the 'go-anywhere' traction of 4wd and the increased manoeuvrability and lighter steering of 2wd.

Choose between push button ESP or our unique five-speed **Dual Clutch auto-transmission** for seamless acceleration over any terrain.

AP Suretrac™ torque-sensitive limited-slip differential for extra grip in slippery conditions.

Power Steering (PS) to greatly reduce steering effort and kickback through the handlebar.

Fourtrax 420 DCT IRS PS 4wd. As Fourtrax 420 DCT PS+

Independent Rear Suspension (IRS) for improved comfort and traction.



For more information on Honda technologies see [page 38](#)



A hard hitting ATV designed to make tough work easy

NEW 4WD Available in Green*

FOREMAN 520

THE ALL-ROUND WORK HORSE

Big loads, long days – no problem. The Honda Foreman is built to deliver solid handling and powerful performance with renowned durability, whatever the conditions.

With huge low down torque delivered by a new, larger fuel efficient liquid cooled 518cc engine, and its computer engineered chassis providing smooth, sure footed handling, the Foreman truly is a joy to ride. Its thick padded saddle makes it easier to tackle a long day out in the field, and the unique Honda TraxLok® allows switchable 2/4wd and push-button full differential lock to give improved traction, even in deep mud. While wide gear ratios provide plenty of pulling power and true engine braking. The PS and IRS models offering reduced steering effort and kickback, or greater ground clearance and shock absorption respectively, allow you to choose a model to suit your particular needs and working environment.

NEW Features

- **Larger 518cc liquid cooled, single cylinder 4-stroke engine**
For increased torque and efficiency
- **Forward/Reverse Skip Switch (DCT & ES)**
Bypass neutral when reversing
- **Redesigned front and rear racks**
Providing a better surface area
- **1.9L water resistant utility box**
Providing useful storage

Foreman 520 4wd. All models have the below features:

- **2/4wd Traxlok®** allows you to quickly switch between tough 4wd and the lighter steering of 2wd.
- **Manual 5-speed transmission** with automatic clutch for excellent control and towing capability.
- **Differential Lock** provides push-button additional traction in slippery conditions.
- **Preload rear suspension** allows the rider to adjust the ride to suit the load, task and conditions.
- **Power Steering (PS)** to greatly reduce steering effort and kickback through the handlebar.

Foreman 520 IRS PS 4wd. As Foreman (above)+

- **Independent Rear Suspension (IRS)** for improved comfort, traction and load handling capability.

Foreman 520 ES PS 4wd. As Foreman (top)+

- **Handlebar mounted Electric Shift Program (ESP)** for quick push-button gear selection.





The Foreman DCT unites durability, performance and comfort

NEW 4WD



FOREMAN 520 DCT

THE POWERFUL 'DO IT ALL' ATV

With long travel independent suspension and huge load carrying capacity, the Foreman DCT is engineered to be the most comfortable and capable ATV ever.

Work smarter, not harder with a Foreman DCT. Built around a solid chassis offering class leading handling, and fitted with IRS and pre-load adjustable twin rear shocks (giving 216mm travel), it'll tackle the toughest terrain without any fuss. Its powerful engine delivers huge torque and our Dual Clutch Transmission (DCT) provides smooth shifts and excellent control. Its optimised shift mapping increasing fuel efficiency, and the new manual-override capability allows the driver to manually change gears even when in automatic mode. This provides a new level of control, making it possible to downshift on corner entry or upshift on descents. Power steering means you can enjoy hours in the saddle without fatigue and the high output headlight offers increased visibility. Pre-load adjustable shock absorbers and a rear disc brake also combine to provide a smoother, more controlled ride.

NEW Features

- **Larger 518cc liquid cooled, single cylinder 4-stroke engine**
For increased torque and efficiency
- **Forward/Reverse Skip Switch (DCT & ES)**
Bypass neutral when reversing
- **Redesigned front and rear racks**
Providing a better surface area
- **1.9L water resistant utility box**
Providing useful storage
- **New shift map**
Monitors RPM in real time shifting
- **Manual override**
Override automatic for added control
- **Redesigned bumper & grill**

Foreman 520 DCT IRS PS 4wd

- **2/4wd** **Traxlok®** allows you to quickly switch between tough 4wd and the lighter steering of 2wd
- **DCT** Our unique, automated **Dual Clutch Transmission** does all the hard work for you, providing seamless, efficient gear changes
- **Differential Lock** provides push-button additional traction in slippery conditions
- **Hi/Lo** **Hi/Lo Gear Range** selector delivers unparalleled low-down load pulling power – up to 600kg
- **Independent Rear Suspension (IRS)** for improved comfort, traction and load handling capability
- **Power Steering (PS)** to greatly reduce steering effort and kickback through the handlebar



MODEL SPECIFICATIONS



FOURTRAX (4WD MODELS)

Fourtrax 420	Fourtrax 420 PS	Fourtrax 420 DCT PS	Fourtrax 420 DCT IRS PS
TRX420FM1, TRX420FE1 (ES)	TRX420FM2	TRX420FA2	TRX420FA6

Utility work ATV

Engine Size	420cc		
Engine Type	Liquid cooled, wet-sump, longitudinally mounted OHV 4-stroke single cylinder		
Bore x Stroke	86.5mm x 71.5mm		
Fuel System	PGM-FI, 34mm throttle-body fuel-injection system		
Ignition	Full-transistorized ignition with electronic advance		
Starter	Electric		
Gears	Five forward gears plus reverse		
Transmission	Auto clutch with manual, or electric shift (FE models only)	Automatic Dual Clutch Transmission (DCT) with auto-shifting or electric shift	
Drive	4wd Direct drive-shafts with TraxLok® switchable 2wd/4wd and locking front differential		
Power Steering	-	Power Steering	
Front Suspension	Independent double wishbone		
Rear Suspension	Swingarm with single shock	Dual A-Arm (IRS)	
Adjustable Pre-load	Front and Rear suspension		Front and Rear suspension
Suspension Travel	Front: 170mm Rear: 170mm	Front: 185mm Rear: 216mm	
Front Brakes	190mm dual hydraulic discs		190mm dual hydraulic discs
Rear Brake	160mm sealed mechanical drum		170mm single hydraulic disc
Tyres	Front: 24 x 8-12 Rear: 24 x 10-11		
Dimensions	L: 2100mm W: 1200mm H: 1170mm		L: 2140mm W: 1200mm H: 1180mm
Wheelbase	1270mm		1295mm
Seat Height	855mm		880mm
Ground Clearance	180mm		230mm
Min. Turning Radius	2.8m		3.5m
Fuel Capacity	4.9L		
Rack capacity	Front: 29.9kg Rear: 60kg		
Towing capacity	384kg		385kg
Dry weight	278kg ES: 279kg	280kg	291kg
Colours	Red and Green (TRX420FM2 only). Optional green panel kits available		

FOREMAN MODELS (4WD)

Foreman 520 PS	Foreman 520 IRS PS	Foreman 520 DCT IRS PS
TRX520FM2, TRX520FE2 (ES)	TRX520FM6	TRX520FA6

Heavy duty ATV

Heavy duty ATV

Engine Size	518cc	
Engine Type	Liquid cooled, wet-sump, longitudinally mounted OHV 4-stroke single cylinder	
Bore x Stroke	96.0mm x 71mm	96.0mm x 71.5mm
Fuel System	PGM-FI, 36mm throttle-body	
Ignition	Full-transistorised type with electronic advance	
Starter	Electric	
Gears	Five forward gears plus reverse	
Transmission	Auto clutch with manual or electric shift (TRX500FE2 (ES) model only)	Automatic Dual Clutch Transmission (DCT) with auto-shifting or electric shift
Drive	4wd Direct drive-shafts with TraxLok® switchable 2wd/4wd and locking front differential	
Power Steering	Power Steering	
Front Suspension	Independent double wishbone	
Rear Suspension	Swingarm with single shock	Dual A-Arm (IRS)
Adjustable Pre-load	Front and Rear suspension	
Suspension Travel	Front: 185mm Rear: 185mm	Front: 185mm Rear: 215mm
Front Brakes	190mm dual hydraulic discs	
Rear Brake	160mm sealed mechanical drum	170mm single hydraulic disc
Tyres	Front: 25 x 8-12 Rear: 25 x 10-12	
Dimensions	L: 2100mm W: 1200mm H: 1210mm	L: 2147mm W: 1205mm H: 1235mm
Wheelbase	1270mm	
Seat Height	870mm	
Ground Clearance	190mm	
Min. Turning Radius	3.2m	
Fuel Capacity	17.7L, incl. 5.9 reserve	
Rack capacity	Front: 39.9kg Rear: 79.8kg	Front: 44.9kg Rear: 84.8kg
Towing capacity	384kg	
Dry weight	294kg ES: 288kg	317.5kg
Colours	Red and Green (TRX520FM2 only)	

MODEL SPECIFICATIONS



UTV MODELS (4WD)

Pioneer 520	Pioneer 700-2	Pioneer 700-4
SXS520	SXS700M2 (two seats)	SXS700M4 (four seats)

Heavy duty UTV Utility Vehicle

Engine Size	518cc	675cc
Engine Type	Liquid cooled, 4-stroke single-cylinder	Liquid cooled, semi-dry sump, longitudinal mounted OHV 4-stroke single-cylinder
Bore x Stroke	96.0mm x 715mm	102.0mm x 82.6mm
Fuel System	PGM-FI, 36mm throttle-body	PGM-FI, 40mm throttle-body fuel-injection system with IACV idle control
Ignition	Full-transistorised type with electronic advance	
Starter	Electric	
Gears	Five forward gears with reverse	Three forward gears with reverse
Transmission	Automatic with auto or manual shift modes	Fully automatic with hydraulic torque converter and electrical controls
Drive	4wd Direct drive-shafts with switchable 2wd/4wd and locking front differential	
Power Steering	-	-
Front Suspension	Independent double-wishbone	
Rear Suspension	Independent double-wishbone (IRS)	
Adjustable Pre-load	Rear suspension	-
Suspension Travel	Front: 147mm Rear: 150mm	Front: 200mm Rear: 230mm
Front Brakes	Dual 200mm hydraulic discs	
Rear Brake	170mm hydraulic disc	170mm single hydraulic/mechanical disc
Tyres	Front: 24 x 8-12 Rear: 24 x 10-12	Front: 25 x 8-12 Rear: 25 x 10-12
Dimensions	L: 2667mm W: 1270 mm H: 1808mm	L: 2910mm W: 1525 mm H: 1970mm
Wheelbase	1854mm	1950mm
Seat Height	-	868mm
Ground Clearance	216mm	270mm
Min. Turning Radius	3.91m	4.511m
Fuel Capacity	15.5L incl. 4L reserve	30L
Bed Capacity	204kg	386kg
Towing capacity	454kg	680kg
Dry weight	483kg	574kg
		639kg
Colours	Red	Red



MODEL CODES EXPLAINED

- T.** 2wd
- F.** 2/4wd
- M.** Manual Transmission
- E.** Electric Shift Transmission
- A.** Automatic Transmission
- 1.** Swingarm rear suspension
- 2.** Swingarm rear suspension plus Power Steering
- 6.** Independent Rear Suspension plus Power Steering
- PS.** Power Steering
- DCT.** Dual Clutch Transmission
- IRS.** Independent Rear Suspension



CE certification for European utility ATVs All Honda utility ATVs destined for European markets are CE certified to specific European legislative requirements and to the needs of our customers. The Honda CE mark is clearly shown printed on the Model Year label, affixed to the front vertical frame tube. **Only ATVs with frame numbers with CE marking integral to the Model Year label**, are covered in the UK under the Honda Manufacturer's 2 Year Warranty. Separate CE stickers anywhere else on the frame tubes, other than printed integral to the Model Year label are unlikely to be genuine, thus should be considered non-CE and a cause for concern. If you have any doubt please have the frame number checked against the Honda UK database to check its origin and compliance to European Legislation. **Only a Honda Authorised Dealer can verify the 2 year CE manufacturer's Warranty.**



TECHNOLOGY GLOSSARY



Manual Transmission

Get full control when manoeuvring or riding over taxing terrain, with manual shift gear changes and an automatic clutch mechanism.



Electric Shift Program (ESP)

Change gears quickly and smoothly, with a simple push of a handlebar mounted button.



Adjustable Preload Suspension

Tailor the ride to suit the load, riding conditions and task at hand, greatly improving comfort and handling.



Independent Rear Suspension (IRS)

Gives increased comfort, greater ground clearance with longer travel shock absorption over tougher terrain, with an improved tow capacity.



2 Wheel Drive Model

Offers lighter steering, agile handling with increased manoeuvrability.



Traxlok® (switchable 2/4wd)

Quickly switch between the nimble manoeuvrability and light steering of 2wd, and the go-anywhere traction of 4wd, with a simple selector lever.



Hi/Lo Gear Range Selector

Delivers more low-down torque, giving plenty of pulling power for heavy loads.



Forward/Reverse Skip

Available on our Electric Shift Program (ESP) and DCT models, this single lever bypasses neutral and allows you to shift easily and quickly between forward and reverse.



Automatic Transmission

Delivering smooth and seamless automatic gear changes, for effortless acceleration over any terrain.



Dual Clutch Transmission (DCT)

Our DCT models provide smooth shifts and excellent control by utilising two clutches. When riding, the next gear change is preselected by the second clutch, and ready to go when needed.



Power Steering (PS)

Reduces steering effort and kickback through the handlebar for extended all-day riding comfort, and improved control. The re-mapped ECU also gives greater steering assist at low speed – ideal for lighter riders, or those who enjoy spending long hours in the saddle.



AP Suretrac™

Delivers torque-sensitive, limited-slip differential for optimum traction in slippery conditions.



Full Differential Lock

Lock the front differential with the push of a button, to drive full power to all wheels – a real benefit in loose or rocky terrain or muddy conditions.



USEFUL TECHNOLOGY

“ We only have one future and it will be made of our dreams, if we have the courage to challenge convention ”

SOICHIRO HONDA

Since 1948, when the Honda Motor Corporation was formed, we have lived by this philosophy. Always challenging the status quo, always asking questions, always learning. Today, Honda is the world's largest engine manufacturer, producing innovative and reliable products for almost every application – from lawnmowers to corporate jets. With every product designed to make life more joyful for you and with less impact to the planet. Where will our dreams take us next?

More Honda power equipment

We've harnessed our engineering expertise and design innovation, to create a wide range of class-leading, 4-stroke petrol and NEW cordless electric power equipment products which make your life and livelihood easier, safer and more enjoyable, including:

- Lawnmowers & Lawn Tractors
- Water Pumps & Generators
- Hedge Trimmers & Tillers

Find out more

www.honda.co.uk | 0345 200 8000*

*Charged at local rates from land lines





PEQ-BROCH-AT0421

Terms & Conditions: This publicity material applies to the UK only. These specification details do not apply to any particular product which is supplied or offered for sale. The manufacturer reserve the right to vary their specification, including colours, with or without notice at such times in such manner as they think fit. Major as well as minor changes may be involved. Every effort, however, is made to ensure the accuracy of the particulars contained in this brochure. Consult the Dealer with whom your order is placed for details of the specification of any particular product. This publication shall not constitute in any circumstances whatsoever an offer by the Company to any person. All sales are made by the Distributor or Dealer concerned subject to and with the benefit of the standard Conditions of Sale and Warranty given by the Distributor or Dealer, copies of which may be obtained from him on request.

Honda (UK) Power Products is a division of Honda Motor Europe Ltd.

Honda (UK) - Power Products

Cain Road, Bracknell, RG12 1HL
 Honda Contact Centre **0345 200 8000***
www.honda.co.uk



Please don't bin me. Pass me on to a friend or recycle me.
 The paper used in this brochure is manufactured using Elemental Chlorine Free pulp, from renewable and fully sustainable timber.

*Charged at local rates from landlines.

