



 **HIGHFIELD**
strength · integrity · style

2015-16 RANGE GUIDE

ENJOY

Highfield inflatables have evolved from over 25 years of development in some of the toughest conditions in the world – the Great Barrier Reef of tropical Northern Australia. As direct descendants of the aluminium hulled Australian Swift range of commercial RIBs, they're tough, reliable and thoroughly tested.

Aluminium has long been the hull material of choice in many parts of the world due to its strength, ease of repair, versatility and above all its weight saving characteristics. Remember, because aluminium won't soak up water, your Highfield will weigh the same in 10 years as it did the day it left the showroom.

The environmental credentials of aluminium are impressive too. A lighter boat needs less power to propel it through the water, which in turn requires less fuel and lowers emissions. Couple this to the fact that the hull is totally recyclable and you can see that a Highfield RIB is an environmentally sound choice.

To ensure the long life of your Highfield RIB, we only use top quality materials. High tensile, marine-grade aluminium is powder coated and baked to ensure a smooth and durable finish, which is environmentally sound. Our tube fabrics are either Valmex® PVC from the reputed Mehler Technologies in Germany, or ORCA® Hypalon, from the standard bearer in commercial tube design, Pennel and Flipo in France. Our minimum tube warranty is 5 years†.

Every Highfield boat is rigorously tested to strict ISO standards before leaving the factory. This comprehensive testing of all of our component parts during manufacture, and our 5 year structural warranty† on all of our boats, means you can have complete confidence in your Highfield RIB.

Commercial users can also benefit from Highfield's proven performance with MCA rating for commercial chartering or working offshore.

Highfield's preferred engine partner is Honda Marine. Both companies have a shared dedication to quality, design improvement, reliability and service that deliver an unbeatable package.

All Highfield hulls have been specifically designed to work with the Honda engine range to deliver the best performance possible. Just speak to one of our expert dealers to find the right boat and engine combination for you.

Honda are pioneers in 4-stroke technology on the water, drawing on years of expertise in automotive engineering to bring you the most responsive, reliable and efficient outboard engines on the market today. All Honda outboard engines are also backed up by an industry-leading 6 year warranty* for complete peace of mind.

For more information on the Honda engine range visit:
www.honda.co.uk/marine



CONTENTS

3	CLASSIC RANGE
	Simple, strong and practical tenders from 2.6m to 3.8m
6	Classic range specifications
7	OCEAN MASTER RANGE
	High performance, supremely capable off shore RIBs from 3.5m to 7.0m
12	Ocean Master range specifications
13	HARBOUR MASTER RANGE
	The versatility of the larger Ocean Master models with additional weather protection
13	Harbour Master range specifications
14	LIGHT COMMERCIAL
	MCA coding for Ocean Master and Harbour Master models

* Subject to following the service schedule, 6 year engine warranty applies to domestic and non-competitive use. 2 year warranty for professional use.



CLASSIC RANGE

Called the Classic range because these really are the perfect all-round tenders that are built to last. Strong, lightweight and dry riding, these boats really do all the things a tender should.

The high quality finish and luxury look belies the fact that this range of tenders has been designed to work hard. A durable aluminium hull coupled with full length keelguards make these ideal for those beach-hopping days with friends and family.

The large weight savings achieved compared to equivalent GRP tenders means you'll enjoy impressive performance with smaller engines, and with excellent payload capacities, the Classic range really does offer a tender for everyone.

A steering console option is available from CL340 upwards, turning the Classic into an easy handling runabout, perfect for having fun when you've anchored in a bay for lunch.

It's the details that make the difference, too. The raised floor means you'll keep your feet and kit dry, even in a very choppy sea. Davit lifting eyes are welded into the deck for easy launching and towing, and heavy duty rubbing strakes will give you peace of mind when coming back alongside.

Standard equipment

- Valmex® PVC tube fabric
- Welded seams
- 5 Year structure and tube warranty (leisure use only)
- Flush mount non-return valves
- Integrated transom supports
- Anchor well (up to CL310)
- Bow locker (CL340 upwards only)
- Removable seat
- Davit lifting eyes and towing points
- Tow bridle points
- Anti-slip deck
- Heavy duty rubbing strake
- Full length keel guard
- Foot pump
- Paddles
- Repair kit

Optional equipment

- ORCA® Hypalon tube fabric
- Transom storage box
- Extra seat
- Seat bags
- Cover
- Bow locker option (CL310 only)
- Console (CL340 upwards only)
- Dinghy wheels
- Dark grey tube fabric option (special order only)





CL290



CL340

CLASSIC
CL260

This compact 2.6m model still has capacity for four people, making it ideal for short tendering trips or just having fun.

CLASSIC
CL290

This agile and strong 4-man model offers slightly more room with up to 480kg payload and 10hp engine.

CLASSIC
CL310

Our easy handling 5-man 3.1m craft is a great all-rounder. The aluminium hull features three lifting points. The optional bow locker is great for storing equipment safely.

CLASSIC
CL340

This versatile 6-man RIB can be fitted with an optional console to make it even easier riding. The bow locker and fuel tank storage as standard make this a popular choice.

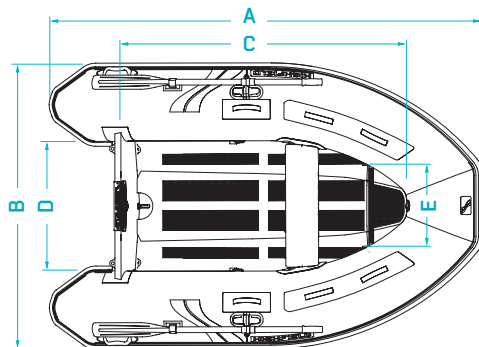
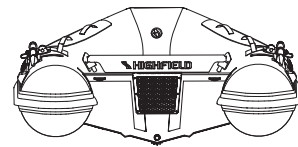
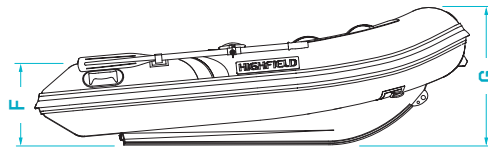

CL260 shown



Optional seat bag

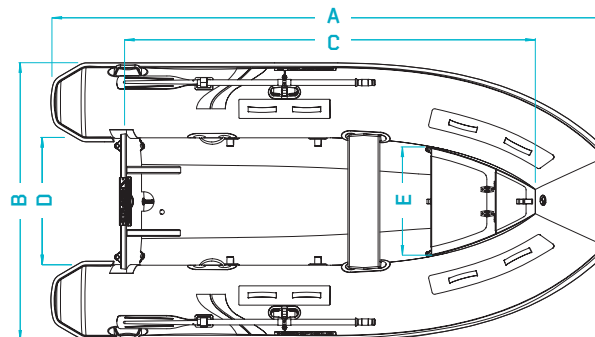
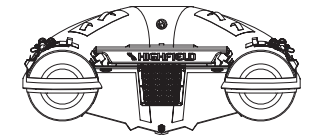
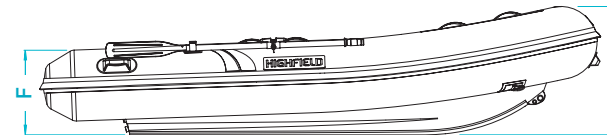

CL340 shown



Integrated bow locker / fuel tank storage (CL340 and above)



CL380

SPECIFICATIONS

CLASSIC

Model	CL260	CL290	CL310	CL340	CL360	CL380
A Length	260cm	290cm	318cm	348cm	366cm	380cm
B Beam	171cm	171cm	171cm	171cm	171cm	171cm
C Inside length	185cm	205cm	226cm	253cm	273cm	290cm
D Inside beam	79cm	79cm	79cm	79cm	79cm	79cm
E Bow width	50cm	55cm	55cm	66cm	66cm	66cm
F Stern height	50cm	50cm	50cm	52cm	52cm	53cm
G Bow height	83cm	83cm	83cm	82cm	82cm	82cm
Dry weight*	40kg	50kg	60kg	68kg	75kg	80kg
Deadrise	20°	20°	20°	20°	20°	20°
Max. passengers	4	4	5	6	6	7
Max. load	430kg	480kg	550kg	620kg	650kg	690kg
Max. engine size	8hp	10hp	15hp	20hp	30hp	30hp
Shaft	Short	Short	Short	Short	Short	Short
Tube Ø	44cm	44cm	44cm	44cm	44cm	44cm
Airtight chambers	3	3	3	3	3	3
Bow locker	-	-	Optional	Standard	Standard	Standard
Fuel tank storage	-	-	-	Standard	Standard	Standard
Console	-	-	-	Optional	Optional	Optional

*weight may vary slightly due to manufacturing tolerances

CLASSIC CL360

A roomy 6-man 3.6m model that combines an impressive 650kg load capacity with great handling. Front locker and fuel tank storage as standard. Optional console and up to 30hp engine capacity.

CLASSIC CL380

Our largest 3.8m Classic makes a great 7-man tender with large front locker and fuel tank storage as standard. Perfect for tendering longer distances or larger loads in comfort.

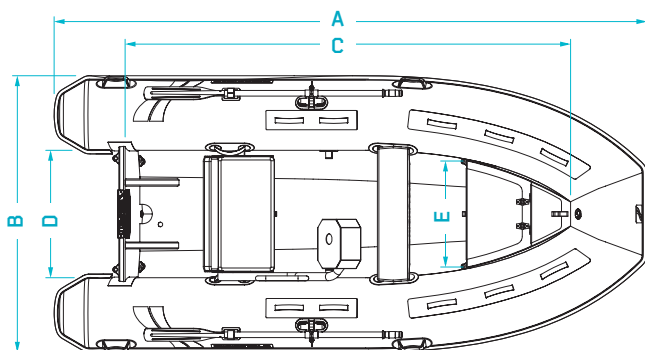
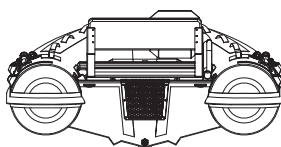
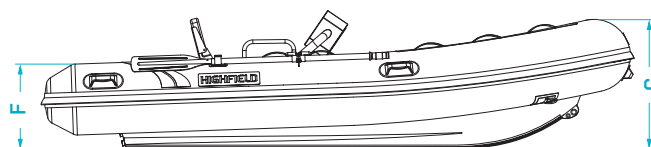

CL360 shown - including optional console

Console option

The optional FCT console gives you forward-facing steering control for intuitive, easy handling with a centrally seated position for increased comfort and greater ease of navigation.





OCEAN MASTER RANGE

Standard equipment

- Valmex® PVC tube fabric
- Welded seams
- 5 Year structure and tube warranty (leisure use only)
- Choice of internal layout
- Integrated under-deck fuel tank
- Flush mount non-return valves
- Anti-slip deck
- Integrated transom supports
- Bow step mooring cleat
- Bow locker with seat cushion
- 4x Davit lifting eyes
- Heavy duty rubbing strake
- Full length keel guard
- Foot pump
- Paddles
- Repair kit

Optional equipment

- Bespoke colour scheme variations available on special order basis
- ORCA® Hypalon tube fabric
- Fully fitted cover
- A-frame with navigation lights
- Electronics package
- Under-deck bilge pump
- Flexible fit-out options available

The 2016 Ocean Master range continues to set the standard as the toughest, most capable and seaworthy RIBs for their size on the market. Go anywhere, in any weather knowing you're in safe hands.

From the compact 3.5m to a spacious new 7.0m model, the flexibility and adaptability of the Ocean Master design allows us to create either a practical family-friendly RIB, a luxury tender or a hard working support vessel.

Whichever model you choose, you can be assured that your Ocean Master is built to last and specified with UK conditions in mind. Internal under-deck fuel tanks, a non-slip self-draining deck (OM420 upwards) and a 24° dead rise (OM460 upwards) let you take on even the toughest conditions confidently.

With the impermeable qualities of our aluminium hulls there's no need to worry about gelcoat chips, or putting the boat on a beach or a trailer. All Ocean Master RIBs are also easy to tow, launch and recover due to their light weight and integrated Davit lifting eyes. Your Highfield Ocean Master won't delaminate or absorb water over time, retaining the same agile performance in 10 years time as the day you collected it.

With MCA rating available, the Ocean Master range is perfect for commercial chartering or working offshore too.

Standard model option

The Ocean Master range offers class leading on-board space in its standard form. This is due to the inherent rigidity of the aluminium hull and compact transom design. Ideal for general leisure use with efficient Honda engines.



DL Model option

More demanding users have the option of our DL models from 5.0m and larger. These feature an uprated aluminium transom and A-frame for improved handling, durability and power transfer with larger capacity Honda engines.





OM390



OM420



OM460

OCEAN MASTER

OM350

An ideal compact yacht tender or small runabout. This 3.5m model is lightweight, agile and capable with superb handling, perfectly suited to an efficient Honda BF20 engine.

OCEAN MASTER

OM390

This 3.9m model makes an ideal yacht tender, runabout or club boat. Capable and responsive handling. An offset console gives plenty of room to move about.

OCEAN MASTER

OM420

Versatile enough to be a great family RIB, club boat or yacht tender. The lightweight yet strong build with self-draining deck also makes this a very capable offshore sea boat.

OCEAN MASTER

OM460

An ideal entry-level family RIB that seats four in comfort. New deeper 24° deadrise V hull for better open water handling, with an integrated under-deck fuel tank for distance cruising.

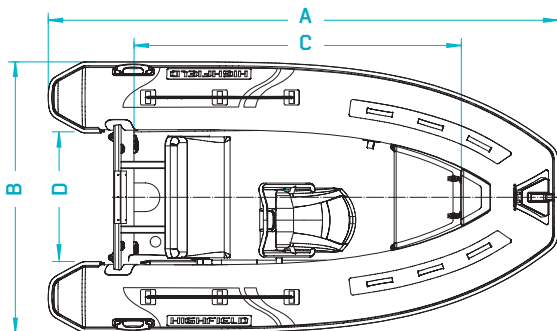
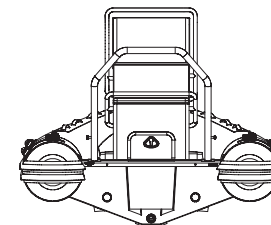
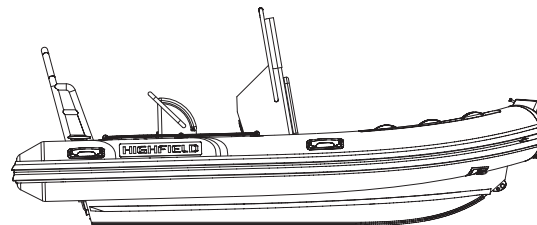
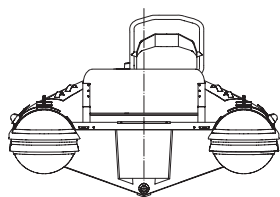
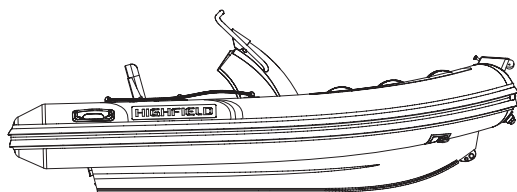

OM350 shown (internal layout can be specified)

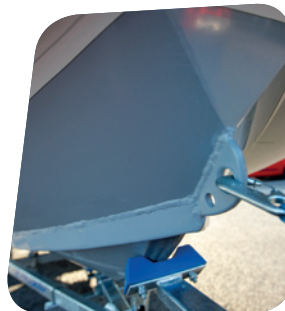

Welded towing/lifting points

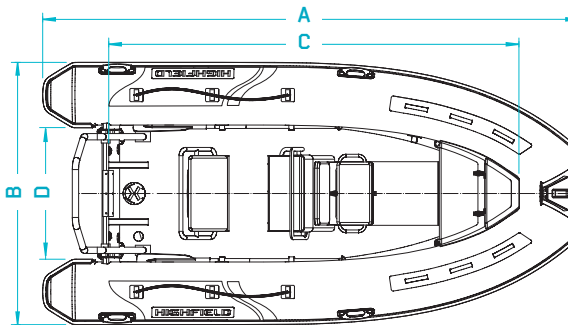

OM420 shown (internal layout can be specified)



Functional control console



QM540DL

OCEAN MASTER

OM500

OM500 **DL** **NEW**

Built to go anywhere with great offshore or distance cruising capability. 24° dead rise and self-draining deck. One of the most spacious 5.0m available.

DL model features uprated transom design.

OCEAN MASTER

OM540

OM540 **DL**

A seriously capable RIB in all conditions. A spacious, stable, quick and comfortable RIB ideal for larger families or groups of friends.

DL model features uprated transom design.

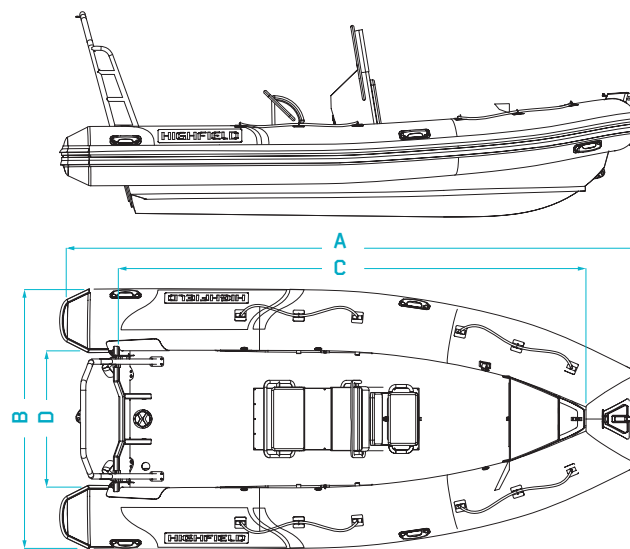

OM540 shown (internal layout can be specified)

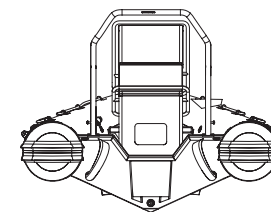

Bow seat storage



OM640DL

OM640DL

OCEAN MASTER

OM590

OM590 **DL**

This 5.9m model offers great onboard space as well as ensuring a soft and dry ride for large families or groups. Long range 140L fuel tank.

DL model features uprated transom design.

OCEAN MASTER

OM640

OM640 **DL**

For those looking for a large capacity yet highly capable off shore cruiser. Long range fuel tank enables long distance cruising in comfort with up to 150hp engine.

DL model features uprated transom design.

OCEAN MASTER

OM700

DL **NEW**

The new 7.0m model offers the onboard space needed for larger group trips, as well as the greater rigidity and larger engine capacity of the DL style transom design.

The OM700DL offers confident handling and sea-keeping ability, as well as comfortable distance cruising even in tough conditions.

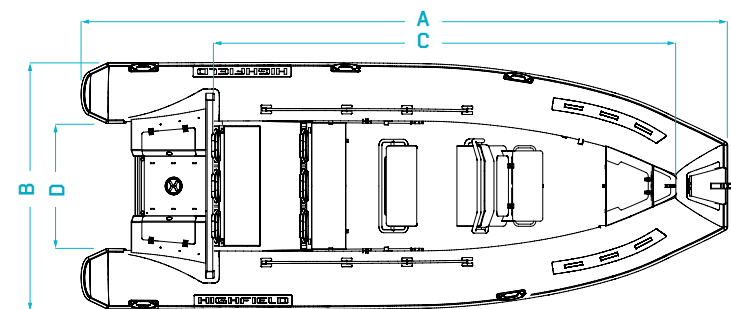
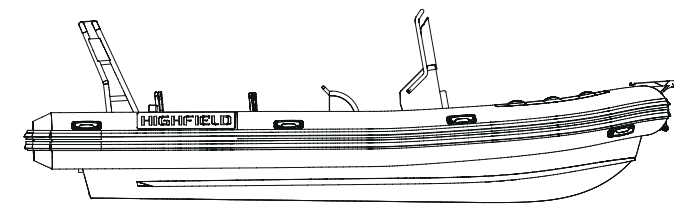

OM640DL shown (internal layout can be specified)

SPECIFICATIONS

OCEAN MASTER

Model	OM350	OM390	OM420	OM460	OM500	OM500DL	OM540	OM540DL	OM590	OM590DL	OM640	OM640DL	OM700DL
A Length	350cm	390cm	420cm	460cm	500cm	500cm	540cm	540cm	590cm	590cm	640cm	640cm	700cm
B Beam	185cm	185cm	210cm	210cm	238cm	238cm	238cm	238cm	244cm	244cm	244cm	244cm	263cm
C Inside length	253cm	285cm	320cm	360cm	385cm	385cm	428cm	300cm	483cm	360cm	540cm	400cm	593cm
D Inside beam	92cm	92cm	108cm	108cm	130cm	130cm	130cm	130cm	130cm	130cm	130cm	130cm	130cm
Dry weight*	98kg	115kg	134kg	168kg	252kg	350kg	320kg	380kg	368kg	400kg	425kg	475kg	575kg
Deadrise	20°	20°	20°	24°	24°	24°	24°	24°	24°	24°	24°	24°	24°
Max. passengers	6	7	8	9	10	10	12	12	14	14	14	16	18
Max. load	660kg	700kg	750kg	820kg	1000kg	1000kg	1200kg	1400kg	1400kg	1400kg	1400kg	1600kg	1800kg
Max. engine size	40hp	50hp	50hp	60hp	100hp	100hp	100hp	115hp	135hp	150hp	175hp	200hp	250hp
Recommended HP	20hp	30hp	40hp	50hp	80hp	80hp	100hp	100hp	100hp	135hp	135hp	150hp	200hp
Engine shaft	Long	Long	Long	Long	Long	Long	X-Long	X-Long	X-Long	X-Long	X-Long	X-Long	X-Long
Tube Ø	47cm	47cm	47cm	47cm	52cm	52cm	52cm	52cm	55cm	55cm	55cm	55cm	55cm
Under-deck fuel tank capacity	42L	42L	50L	50L	100L	100L	100L	100L	140L	140L	140L	140L	190L
Airtight chambers	3	3	4	5	5	5	5	5	6	6	6	6	6
Self-draining deck	–	–	Standard	Standard	Standard	Standard	Standard	Standard	Standard	Standard	Standard	Standard	Standard
MCA commercial rating †	Optional	Optional	Optional	Optional	Optional	Optional	Optional	Optional	Optional	Optional	Optional	Optional	Optional

* Hull and tubes only. Weight may vary slightly due to manufacturing tolerances.

† MCA Category 4 rating allows commercial use up to 20 miles from a safe haven, in favourable weather & daylight.

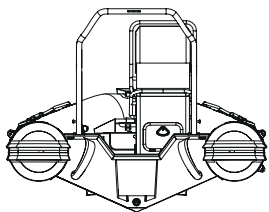

Ideal for towed watersports

OPTIONS

A range of options, accessories and commercial-specific features can be included with your Highfield to make it perfect for your requirements.

For further details, talk to your Authorised Highfield dealer.



Easy towing, launch and recovery with model-specific trailers available



Choice of internal layout with integrated storage

HARBOUR MASTER RANGE

The Harbour Master offers even greater practicality with added weather protection.

The addition of the semi pilot house transforms the already versatile Ocean Master range into a truly practical RIB or family cruiser that keeps you sheltered from the worst of the weather. Available in 5.4m, 5.9m, and 6.4m models with comfortable standing room and excellent all-round visibility, this also makes an ideal fishing craft – especially when combined with the optional integrated bait well.

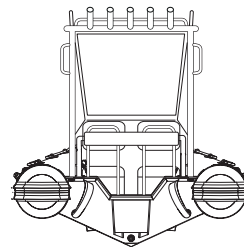
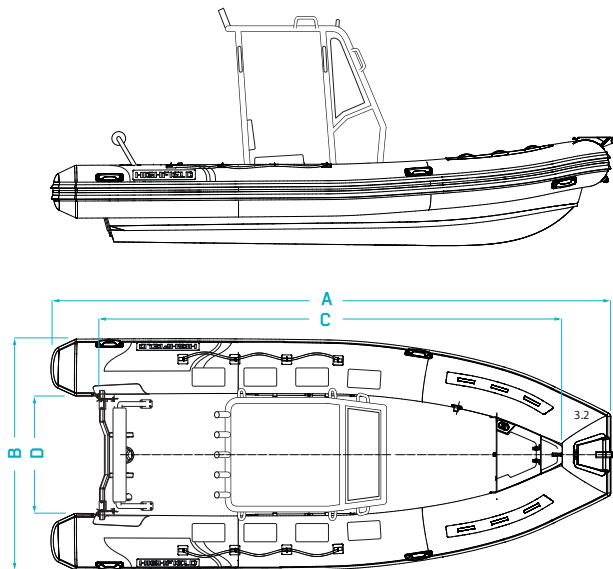

All-weather protection for year round use

HM540 shown (internal layout can be specified).

HARBOUR MASTER

Model	HM540	HM590	HM640
A Length	540cm	590cm	640cm
B Beam	238cm	244cm	244cm
C Inside length	428cm	483cm	540cm
D Inside beam	130cm	130cm	130cm
Dry weight*	420kg	480kg	568kg
Deadrise	24°	24°	24°
Max. passengers	12	14	16
Max. load	1200kg	1400kg	1600kg
Max. engine size	100hp	135hp	175hp
Recommended HP	100hp	100hp	135hp
Engine shaft	X-Long	X-Long	X-Long
Tube Ø	52cm	55cm	55cm
Under-deck fuel tank capacity	100L	140L	140L
Airtight chambers	5	6	6
Self-draining deck	Standard	Standard	Standard
MCA commercial rating †	Optional	Optional	Optional

*weight may vary slightly due to manufacturing tolerances.

† MCA Category 4 rating allows commercial use up to 20 miles from a safe haven, in favourable weather & daylight.

LIGHT COMMERCIAL

Looking for a tough working boat, or a charter boat you can depend on in any conditions? The MCA coding option means that the Ocean Master and Harbour Master are the ideal platforms for commercial users.

The highly adaptable and capable Ocean Master and Harbour Master designs are ideally suited to the harsh demands of commercial use. Their qualities have enabled us to offer an MCA code rating for charter or commercial work.

With commercial options from OM500 upwards, you can be assured of a hard working, safe and economical work boat that can be totally customised to your requirements.



Highfield Marine Ltd.

2 Cannon Road
Heathfield
Newton Abbot
Devon
TQ12 6SH

t: 01626 834 143
e: sales@seaswift.co.uk
w: www.highfieldboats.com



Terms & Conditions:

This publicity material applies to the UK only.

These specification details do not apply to any particular product which is supplied or offered for sale. The manufacturer reserves the right to vary their specification, including colours, with or without notice at such times in such manner as they think fit. Major as well as minor changes may be involved. Every effort, however, is made to ensure the accuracy of the particulars contained in this brochure. Consult the Dealer with whom your order is placed for details of the specification of any particular product. This publication shall not constitute in any circumstances whatsoever an offer by the Company to any person. All sales are made by the Distributor or Dealer concerned subject to and with the benefit of the standard Conditions of Sale and Warranty given by the Distributor or Dealer, copies of which may be obtained from them on request.



Please don't bin me. Pass me on to a friend or recycle me.

The pulp in the manufacture of this paper is from renewable timber produced on a fully sustainable basis. The paper used in this brochure is manufactured using ECF (Elemental Chlorine Free) pulp.